

25 June 1998

**Summary Report of the
Cooperative and Autonomous Workshop
27 and 28 April 1998, Washington, DC**

**Conducted by
The National Automated Highway System Consortium
For The United States Department of Transportation**

William B. Stevens

Contract Sponsor: Federal Highway Administration
Contract No.: DTFH61-97-C-00040
Project No.: 099718D3-0A

**Mitretek Systems, Inc
McLean, Virginia**

Table of Contents

<u>Section</u>	<u>Page</u>
Executive Summary	4
1 Introduction	9
1.1_ Workshop Goal and Scope	9
1.2_ Background	9
2 Workshop Overview	12
3 Workshop Results	15
3.1 USDOT Perspective	15
3.2 NAHSC Perspective	15
3.3 Autonomous Collision Countermeasure Systems	16
3.4 How Cooperative Systems Can Help	16
3.5 Quantitative Analyses of Cooperative and Autonomous Vehicle-Highway Systems	18
3.6 Safety and Capacity Analyses: Cooperative and Autonomous	18
3.7 Analysis of Transmitted Information—ACC Analyses	19
3.8 System Performance for Differing Levels of Cooperation	20
3.9 Evaluation Systems and Tools Status	21
3.10 Lessons Learned from Demo '97 on Cooperative and Autonomous Systems	21
3.11 Societal and Institutional Lessons Learned for IVI	22
3.12 Agency Issues and Concerns	22
3.13 Case Studies	23
3.14 Liability Issues	24
3.15 Understanding and Involving Stakeholders	24
3.16 Needed Human Factors Research	25
3.17 Critical Enabling Technologies	26
3.18 Market Packages for Cooperative Systems	27
3.19 Deployment: How Do Progressively Advanced Systems Roll Out Over Time?	29
3.20 Arizona's I-10 Intelligent Express Lane	29
4 Discussions	31
4.1 First Day	31
4.2 Second Day	32
References	36

Table of Contents (Concluded)

<u>Section</u>	<u>Page</u>
Tables	
1. Workshop Attendees	13

2. Workshop Agenda

14

Appendices

**Separately
Bound**

- A NAHSC Perspective
- B Autonomous Collision Countermeasure Systems
- C How Cooperative Systems Can Help
- D Quantitative Analyses of Cooperative and Autonomous Vehicle-Highway Systems
- E Safety and Capacity Analyses: Cooperative and Autonomous
- F Analysis of Transmitted Information—ACC Analyses
- G System Performance for Differing Levels of Cooperation
- H Evaluation Systems and Tools Status
- I Lessons Learned from Demo '97 on Cooperative and Autonomous Systems
- J Societal and Institutional Lessons Learned for IVI
- K Agency Issues and Concerns
- L Case Studies
- M Liability Issues
- N Understanding and Involving Stakeholders
- O unused
- P Needed Human Factors Research
- Q Critical Enabling Technologies
- R Market Packages for Cooperative Systems
- S Deployment: How Do Progressively Advanced Systems Roll Out Over Time?
- T Arizona's I-10 Intelligent Express Lane
- U NAHSC Perspective and Accomplishments Report

Executive Summary

This document summarizes the Cooperative and Autonomous Systems Workshop presented by the National Automated Highway System Consortium (NAHSC) to the U.S. Department of Transportation (USDOT) on the 27th and 28th of April, 1998. The Workshop goal was to transfer the knowledge gained by the NAHSC regarding cooperative and autonomous systems to the USDOT's Intelligent Vehicle Initiative (IVI) team.

An “*autonomous*” vehicle system is defined as one that is expected to work reliably without help, regardless of the ambient or external state. A “*cooperative*” system is one in which performance is enhanced through some form of cooperation between the vehicle and other vehicles or the infrastructure; this cooperation could be as simple as reflectors on the rear of all vehicles; or complex as continuous communications between close vehicles or with the infrastructure.

Workshop Format

The Workshop covered two full days. The USDOT limited attendance to the government's IVI team and Consortium presenters to help maximize the opportunity for free and open discussions. A total of 36 people attended the Workshop.

Brief introductions were given by both USDOT and NAHSC representatives to set the stage for the Workshop. The state-of-the-art for autonomous vehicle collision avoidance systems was then given followed by a briefing defining cooperative systems and how they might help solve some of the problems faced by autonomous systems. Follow-on briefings then presented detailed analytical and demonstration data that showed what the effect of cooperation might be on autonomous collision avoidance systems. Briefings on topics that cut across both autonomous and cooperative systems were then given on topics such as societal and institutional lessons learned, liability, use of case studies, need for human factors research, critical enabling technologies, market packages, and evolution of collision avoidance systems.

Discussion periods were held at the end of both days so that key points and implications could be discussed. The goal was not that everyone had to agree by the end of the two days, but that the pros and cons of all issues were known and discussed by the attendees.

Key Points

Some of the key observations and conclusions made in the presentations were as follows:

- The Workshop summarized only a small part of the overall NAHSC work; other documentation is available that describes the NAHSC's total work effort (Section 1.2, *Background*, and Section 3.1, *NAHSC Perspective*)
- Today's autonomous systems technologies cannot reliably perform the required

- tasks of collision avoidance except for basic systems that only provide driver warning (Section 3.2, *Autonomous Collision Countermeasure Systems*)
- Cooperative systems, even inexpensive passive cooperation, can substantially increase the accuracy and robustness of collision avoidance systems (Section 3.3, *How Cooperative Systems Can Help*)
 - The NAHSC has developed a suite of tools for estimating the benefits of collision avoidance services; additional work is needed to complete the tailoring of these tools for IVI (Section 3.4, *Quantitative Analyses of Cooperative and Autonomous Vehicle-Highway Systems*, and Section 3.8, *Evaluation Systems and Tools Status*)
 - Cooperation of collision avoidance systems would greatly increase both vehicle safety and highway capacity (Section 3.5, *Safety and Capacity Analysis*)
 - As the level of cooperation of Adaptive Cruise Control (ACC) systems increases, the level of safety and capacity would increase, and the driver's level of comfort would increase because of fewer false alarms (Section 3.6, *Analysis of Transmitted Information*)
 - Autonomous ACC vehicles would actually decrease highway throughput at lower market penetration levels; this is because of the conservative vehicle separations that would be maintained. As autonomous ACC market penetration continues to grow beyond 50 percent, there would be a slight increase in throughput. Cooperative ACC vehicles would increase highway throughput as vehicle penetration increases to the point that some cooperation becomes possible. Throughput could double when 100 percent market penetration is reached (Section 3.7, *System Performance for Differing Levels of Cooperation*)
 - Detailed data collected at the 1997 Demonstration in San Diego confirmed the modeling and simulation results showing that the cooperative systems demonstrated had higher accuracy, less sensing noise, better opportunities possible for fault detection and data fusion, and more robustness to accommodate component failures when compared to specific autonomous systems (Section 3.9, *Lessons Learned from Demo '97 on Cooperative and Autonomous Systems*)
 - Ten of the twelve societal and institutional areas that were researched by the Consortium are directly applicable to the IVI; this includes liability, licensing, transit use, etc. (Section 3.10, *Societal and Institutional Lessons Learned*)
 - The NAHSC case studies were very useful in both assessing new technologies in a real world environment, and in building grass-roots support for the services. Case studies will be a necessary preliminary step for IVI operational field tests (Section 3.12, *Case Studies*)

- If the overall safety of the vehicle-highway system is increased, then liability was not viewed as a major problem by attendees at a Liability Workshop (Section 3.13, *Liability Issues*)
- Human factors research is necessary, particularly for systems in which additional information is presented for quick use by the driver, or where partial vehicle control is assumed; inattentiveness may increase as the level of control assumed increases (Section 3.15, *Needed Human Factors Research*)
- Ten capabilities needed for many of the IVI collision avoidance systems were the focus of NAHSC research. The problems in developing these capabilities must be solved before effective collision avoidance systems can be developed:
 - ◆ Know where other vehicles are
 - ◆ Handle obstacles
 - ◆ Know vehicle location in the lane
 - ◆ Control the vehicle
 - ◆ Know absolute position while moving
 - ◆ Know vehicle braking capability
 - ◆ Know other vehicle movement and intent (vehicle-vehicle communications)
 - ◆ System reliability
 - ◆ Avoid clutter in environment
 - ◆ Miscellaneous (actuators, entry and exit, driver condition monitoring, etc.)

The biggest challenges will be:

- ◆ Obstacle detection
- ◆ Predicting braking capability
- ◆ Separating returns from clutter
- ◆ System reliability
- ◆ Human factors

While some functions can be performed autonomously, cooperation (even passive cooperation) will help perform many of the critical functions, and will enhance autonomous operation when cooperation is possible (Section 3.16, *Critical Enabling Technologies*)

- An analysis of the services that involve driver warning and/or vehicle control identified 93 separate services or market packages, each with its own level of capability. An additional analysis looked at what cooperation would add to these services. It was concluded that even a small degree of cooperation can have a big benefits payoff (Section 3.17, *Market Packages for Cooperative Systems*)

- The Consortium had addressed the “chicken-and-egg” problem; why would consumers buy vehicles if the infrastructure is not equipped for cooperation; and why would transportation agencies equip roadway for equipped vehicles if there are none? Several transition approaches were described to show that evolution to cooperative systems is possible (the cellular telephone is a recent example). But it was pointed out that the transition would not occur without a long term goal, a public/private partnership, and USDOT support (Section 3.18, *Deployment: How Do Progressively Advanced Systems Roll Out Over Time?*)
- There is considerable interest among some state and regional transportation agencies to move forward with more fully automated systems because of the potential benefits; one example of this was given discussed. The Arizona Department of Transportation worked jointly with the NAHSC in a case study of the highway between Phoenix and Tucson. A plan was laid out for evolving from today’s new express lanes to a fully automated roadway in 20 years (Section 3.19, *Arizona’s I-10 Express Lane*)

Incomplete Work

Because of the abruptness with which the Consortium work ended, there are many areas in which Consortium work is incomplete and in which further research and analyses are needed as the IVI program proceeds. Some, but not all, were discussed at the Workshop. Below is a summary of those discussed during the two days;

- The tool set developed by the NAHSC was partially modified to allow its use for IVI collision avoidance services; completion of the modification of this tool set would give the IVI some very powerful tools for continued benefits evaluation.
- The 1997 demonstration provided an opportunity to view actual performance variations between autonomous and cooperative systems; additional prototype testing could provide the basis for solid decision-making by the IVI team.
- The IVI program will need the support of the community and the state and regional transportation agencies as concepts and designs are proposed, and as field operational tests are planned. The NAHSC work in societal and institutional issues should be extended to IVI; in particular, case studies leading to field operational tests will be necessary.
- Enabling technologies are crucial to IVI; several promising enabling technology research efforts had to be terminated before results were known and before their full potential could be assessed. Some of these should be continued.
- There are several human factors issues that should be addressed prior to definition of IVI field operational tests.
- The IVI program needs to define some long term goals to bring meaning and focus to the near term efforts, and to allow planning to begin on how collision avoidance services should/could evolve from today to meaningful benefits in the future.

Goals Were Met

The USDOT indicated that their goals for the workshop were met. The USDOT will determine the extent to which the IVI program will invest in cooperative systems and longer term research so that effective, robust collision avoidance systems can be available in the twenty first century.

Introduction

This document summarizes the Cooperative and Autonomous Systems Workshop presented by the National Automated Highway System Consortium (NAHSC). The Workshop was held at the Loew's L'Enfant Plaza Hotel in Washington, D.C. on the 27th and 28th of April, 1998.

1.1_ Workshop Goal and Scope

The Workshop was requested by the United States Department of Transportation (USDOT) as the final deliverable of the NAHSC. The goal was to transfer the knowledge accumulated by the consortium regarding cooperative and autonomous systems to the USDOT's Intelligent Vehicle Initiative (IVI) program personnel so that they could determine the extent to which cooperative programs might be a part of the IVI program.

The Workshop materials provided a high level summary of the work done over the past year that directly relates to both autonomous and cooperative systems. In addition, an overview was provided of some work that cuts across both autonomous and cooperative systems:

- Societal and Institutional
- Human Factors
- Stakeholder Interaction
- Enabling Technologies
- Evolution of Automated Vehicle-Highway Technologies

There were several major NAHSC efforts in the past year that were not addressed in the Workshop [1]. These efforts are described in the next section, under *Consortium Redirection and Termination*.

1.2 Background

The AHS Program – The USDOT established an Automated Highway System (AHS) program because research has clearly indicated that automated vehicle control can offer major improvements in highway safety and efficiency [2]. The AHS program goal was to apply computer, communications and vehicle control technologies to the U.S. vehicle-highway system in order to greatly improve highway safety and efficiency in the twenty-first century, in many cases using the existing highway infrastructure. A key element was definition of the evolution from the near-term use of automation technologies for vehicle safety, to fully controlled vehicles in the future [3].

The NAHSC Formation – In late in 1993, the USDOT issued a request for applications for a cooperative research and development program that would lead to a prototype fully automated AHS [3]. In October, 1994, the NAHSC was selected after competitive evaluation. The agreement between the NAHSC and the USDOT charged the NAHSC to demonstrate AHS technical feasibility in 1997, and identify, prototype and specify the preferred AHS concept for the U.S. in the 21st century. The NAHSC agreed to share at least 20 percent of the total cost, without any profit or fee, and to use 35 percent of all federal funds for contracting with non-Core

Participants.

The Consortium was a unique public/private partnership whose mission was to evaluate AHS potential, and to specify and prototype a practical AHS for deployment in the United States. It is expected that AHS will be the next major improvement in our surface transportation system. An integral part of this effort was to foster the development and early application of safety and control technologies to provide early benefits to all highway users. The nine Core Participants were Bechtel, the California Department of Transportation (Caltrans), Carnegie Mellon University, Delco Electronics, General Motors, Hughes Aircraft, Lockheed Martin, Parsons Brinckerhoff and the University of California's Partners for Advanced Transit and Highways (PATH).

In addition to the Core Participants, the NAHSC included over 120 Associate Participants representing nine categories of stakeholders in the future of highway transportation: (1) local and state government agencies, (2) transportation users, (3) transit, (4) environmental interests, (5) highway design industry, (6) vehicle industry, (7) electronics industry, (8) commercial trucking interests, and (9) insurance industry. There were provisions for representation of each category in the Consortium's decision-making process [4].

The Role of Cooperation – The consortium allowed for the collaboration of the roadway infrastructure designers with vehicle designers and leaders in the development and application of information and control technologies. A primary focus of the NAHSC effort was on analyzing automated vehicle-highway control assuming that the highway and the vehicles that travel on them are a single system. Consortium research showed that maximum benefits could be achieved with cooperation among the vehicles and the highway, and cooperation from vehicle to vehicle. It appeared that with cooperative systems, the risk of having a crash could be reduced by 50 to 80 percent, and the capacity of a highway lane could be doubled or tripled [5]. It was for these reasons that the NAHSC became convinced that cooperative systems should be part of the U.S. vehicle-highway system future.

Consortium Redirection and Termination – In March 1997, the USDOT redirected the NAHSC to focus on near-term benefits of the Advanced Vehicle Control and Safety System technologies. The accomplishments of the NAHSC from its beginning until March 1997 have been documented in a report entitled *NAHSC Perspective and Accomplishments*, July 1997 (Appendix O of this report). Then in December 1997, the USDOT notified the NAHSC that it was withdrawing from the Consortium and would no longer cost share the Consortium expenses.

In the period of time from March through December 1997, the consortium pursued its modified work program. Some of this work, but not all, is described in other documentation, as described below:

- 1997 Demonstration of Technical Feasibility – This congressionally mandated

- event was the most successful event in ITS history. Over four thousand people attended this four-day event in San Diego in August; and many of them were able to ride in one of the 22 automatically controlled vehicles. Over 95 percent of the people who got this glimpse at the future of automated vehicle warning and control felt it was a good idea [6].
- Concept Definition and Selection – This effort was restructured to focus on (1) the near-term systems that could possibly evolve into a fully automated AHS system and how they relate; and (2) cross-cutting issues that are of concern to both near-term and longer-term vehicle-highway systems such as roadway obstacle analysis [7].
 - Termination Activities – Documentation of some of the other NAHSC efforts in this interim period was included in the “NAHSC Termination Activities”—a negotiated set of activities that the NAHSC was to perform as it concluded its operation [8]. The Termination Activities were selected by the USDOT, and they included documentation of some but not all of the NAHSC’s interim efforts. This documentation is captured in a series of reports provided electronically to the USDOT in March 1998. The work areas included in the Termination Activities are as follows:
 - Technology Assessments – interim or final reports on some of the enabling technology studies
 - Tools and Models – documentation of the tools and models used by the NAHSC to generate results for both fully and partially automated systems
 - Automated Vehicle Control Services Analyses – analyses of the services and market packages related to AHS and IVI, and analyses on how they could evolve
 - Demonstration and Service Testing – descriptions of case studies and mini-demonstrations sponsored by the NAHSC beyond the 1997 demonstration
 - Societal and Institutional Concerns – wrap-up of the efforts to address the non-technical concerns with automated warning and control systems, including documentation of workshops on liability and land use

As part of the NAHSC Termination Activities, the USDOT requested that the Consortium hold a Workshop in April that would focus on the relative characteristics, system safety and performance of both cooperative and autonomous collision mitigation systems.

2 Workshop Overview

The two-day Workshop was structured to provide maximum transfer of knowledge from the Consortium members to the government's IVI team. This was done by limiting the number of attendees and providing ample opportunities for discussion. The USDOT limited the invitation list to just government members of the IVI team plus those Consortium members that would be briefing the materials. The list of attendees is shown in Table 1. The agenda was then structured so that questions could be asked of each presenter; in addition, one hour (or more) discussion periods were included at the end of both days for more in-depth discussion of any issues, concerns or disagreements. The Workshop agenda is in Table 2.

The program began with an introduction by Dr. James Rillings of the General Motors Research Laboratories; Jim was the Moderator for the workshop. This was followed by introductory remarks from John MacGowan of the Federal Highway Administration. Jim Lewis of Raytheon, co-organizer of the Workshop, then gave a Consortium perspective that showed how the Workshop related to the overall NAHSC program and described how the Workshop was organized.

After the introductions, the state of the art of autonomous collision mitigation systems was given by Dr. Roger Fruechte, GM. The briefing described the shortfalls that inhibit the fielding of these systems. This was followed by a briefing by Dr. Steven Shladover, PATH, that (1) defined a wide variety of cooperative systems; and (2) showed how augmentation of autonomous systems with cooperation can help overcome some of the autonomous system shortfalls.

A series of briefings then provided in-depth quantitative data regarding the safety and performance of cooperative and autonomous systems. These analyses, presented by two members of the NAHSC tools and modeling efforts, were for a wide variety of assumptions. This was followed by a presentation of the hard performance data, for both cooperative and autonomous systems, captured during the AHS Demo '97. These data correlated to the assumptions made in the quantitative analyses.

A series of briefings addressing topics that cut across both autonomous and cooperative systems were made. The societal and institutional perspectives on deployment of collision mitigation systems were given, including descriptions of the Consortium's case studies and results from the Consortium-sponsored Liabilities workshop. This was followed by a presentation of some of the NAHSC's human factors efforts. Next, a discussion of the consortium's research of the critical enabling technologies was given along with some of the initial R&D findings. Finally, evolution from today to cooperative automated vehicle control and safety systems was addressed.

Table 1. Workshop Attendees

Federal Highway Administration:

- Bob Ferlis
- John Harding
- Kate Hartman (Office of Motor Carriers)
- John MacGowan
- George Ostensen

Federal Transit Administration:

- Jill Hough

ITS Joint Program Office:

- Ray Resendes

Mitretek Systems:

- Kevin Dopart
- John Eicher
- Bill Jeffrey
- Rodney Lay
- Dale Nussman
- Bill Stevens
- Phil Tarnoff

National Highway Traffic Safety Administration:

- August Burgett
- Al Chande
- Lloyd Emerson
- Joe Kanianthra
- Duane Perrin
- David Smith

National Automated Highway System Consortium

- Janie Blanchard
- Roger Fruechte
- Datta Godbole
- Bob Hogan
- Carol Jacoby
- Greg Larson
- Jim Lewis
- Alan Lubliner
- Tom McKendree
- Rob Meinert
- Jim Misener
- Joe Perkowski
- Jim Rillings
- Steven Shladover
- Jerry Sobetski
- Chuck Thorpe

Table 2. Workshop Agenda

MONDAY, 27 APRIL, 1998

8:00 AM	INTRODUCTION	Jim Rillings
8:10 am	USDOT Perspective	John MacGowan
8:20 am	NAHSC Perspective	Jim Lewis
8:45 AM	AUTONOMOUS COLLISION MITIGATION SYSTEMS	Roger Fruechte
9:15 AM	HOW COOPERATIVE SYSTEMS CAN HELP	Steven Shladover
10:00 AM	QUANTITATIVE ANALYSIS OF COOP. AND AUTON.	Jim Misener
10:15 am	Safety analysis, cooperative and autonomous	Datta Godbole
11:00 am	Analysis of transmitted information versus performance	Datta Godbole
11:45 AM	LUNCH	
12:15 pm	System performance for differing levels of cooperation	Jim Misener
12:45 pm	Evaluation systems and tools status versus IVI needs	Jim Misener
1:00 PM	QUANTITATIVE DATA FROM THE '97 DEMO	Steven Shladover
1:45 PM	SOCIETAL & INSTITUTIONAL PERSPECTIVES	
1:50 pm	Lessons Learned for IVI	Alan Lubliner
2:20 pm	Agency Issues and Concerns	Alan Lubliner
2:45 pm	Case Studies	Greg Larson
3:15 PM	NEEDED HUMAN FACTORS RESEARCH	Bob Hogan
4:00 PM	DISCUSSIONS	Jim Rillings

TUESDAY, 28 APRIL, 1998

8:00 AM	SOCIETAL & INSTITUTIONAL PERSPECTIVES (CONT.)	
8:00 am	Liability Issues	Janie Blanchard
8:15 am	Understanding and Involving the Stakeholders	Roger Boothe
8:30 am	Conclusions and Recommendations for Future Research	Alan Lubliner
8:45 AM	CRITICAL ENABLING TECHNOLOGIES	Chuck Thorpe
12:30 PM	LUNCH	
1:00 PM	EVOLVING TO COOPERATIVE SYSTEMS	Jim Lewis
1:00 pm	Market Packages for Cooperative Systems	Carol Jacoby
1:40 pm	Deployment: How Progressively Advanced Systems Phase In	Tom McKendree
2:20 pm	Arizona's I-10 Intelligent Express Lanes	Jim Lewis
2:45 PM	DISCUSSIONS ON RECOMMENDATIONS FOR IVI	Jim Rillings

3 Workshop Results

The key points of each presentation are given below, and any discussion that occurred during and after the presentation is summarized. The descriptions are in the order of the Workshop agenda. The speaker's name and organization are given after the title.

3.1 USDOT Perspective – John MacGowan, FHWA

The primary USDOT goals for the Workshop were as follows:

- The FHWA is proud of the long-term vision developed by the Consortium, and felt that a platform was needed so that the NAHSC findings could be shared.
- The USDOT IVI team should be exposed to the Consortium's ideas; the Workshop brings the government's IVI team together with the Consortium researchers so that the exchange can happen.
- The NAHSC research results will give balance to the IVI effort.
- There does not need to be consensus among all of the participants; however, there does need to be discussion and an understanding of the issues and concerns.

There were no briefing charts for this presentation.

No comments were received.

3.2 NAHSC Perspective – Jim Lewis, Raytheon

This presentation discussed the NAHSC work plan as originally agreed to by the USDOT and the nine individual Core Participants of the NAHSC. It briefly described how the Consortium's work plan evolved as the technical studies progressed and as feedback was received from the Consortium-sponsored workshops. The impact on the NAHSC work of the USDOT work redirection of March 1997 was then described. Finally, the structure of the Workshop was summarized.

The major program issue to be addressed by the Workshop was the balance between cooperative and autonomous systems. The NAHSC focused on cooperative systems because of the participation by a broad range of stakeholders and because cooperative systems appeared to be the most beneficial.

The briefing charts are contained in Appendix A.

No comments were received.

3.3 Autonomous Collision Countermeasure Systems – Roger Fruechte, GM

An autonomous vehicle system was defined as “one that is expected to work reliably, without help, regardless of the ambient or external state.” The main concerns of a vehicle manufacturer in considering offering such a system are reliability (survive the environment and do the intended task correctly) and cost. It was shown that as systems move from (1) providing information; to (2) warning the driver; to (3) partially or fully controlling the vehicle; the system cost, required reliability and potential liability all rise.

The talk then focused on the tasks to be performed and the current technologies available to perform them. The presentation concluded that today’s autonomous technologies cannot reliably perform the required tasks except for the most basic systems that provide information to the drivers; and these will have a high false return rates. For this reason, vehicle manufacturers will be slow to introduce these systems to the marketplace.

The briefing charts are contained in Appendix B.

Question: Today’s planned IVI effort has little effort on reliability and cost since it is product development. Is there anything that the federal government can do to help?

Answer: Research on basic technologies.

Question: Reliability refers to system reliability?

Answer: Correct.

Question: Where would you spend \$200 million to get collision avoidance?

Answer: I would spend at least 50 percent to make sure all highways are consistently marked and sensor friendly to help reduce false positive returns. This would allow the vehicle manufacturers to use less expensive sensors and get higher reliability.

Comment: The government has a lot of information on false positive returns and the reliability of target identification that could potentially be of value in the development of autonomous collision countermeasure systems.

3.4 How Cooperative Systems Can Help – Steven Shladover, PATH

This briefing described the different kinds of cooperative systems, and how they might help solve some of the problems of autonomous systems operation. Eight types of cooperative systems were defined and examples were given. They included vehicle-to-vehicle cooperation (active and passive); vehicle-to-infrastructure cooperation (active and passive); infrastructure protection (active and passive); and other (active and passive). Passive systems include systems features such as reflectors or consistently painted roadway lines. Active systems include communications devices. The presentation then described how each type of cooperative system could help reduce the problems of autonomous operation by:

Simplifying

- sensor signal processing through target identification
- Providing multiple independent sources of information for data fusion
- Providing alternate information sources for fail-soft operation in case of failures
- Providing higher accuracy and reliability in operation
- Reducing false alarm rates
- Providing more fault-tolerant systems response
- Allowing less expensive in-vehicle systems
- Enhancing autonomous systems operation—as penetration of cooperative systems increases, so will systems effectiveness

The briefing charts are contained in Appendix C.

Question: Has there been any quantification of the expected benefits of cooperative systems?

Answer: Yes; they are covered in the following briefings.

Question: How do we sort out the priorities for infrastructure cooperation from the priorities for vehicle cooperation? Can all of the cooperation be built into the infrastructure not the vehicle?

Answer: In a cooperative system, the highway and vehicles must be viewed as a single system; the balance of components between infrastructure and vehicles will then be based on what is most cost-effective and beneficial.

Question: Is it true that the data exists to support the claims of benefits in the NAHSC work?

Answer: There is some support, but it is not as thorough as we would like it to be. Tools to quantify benefits were developed, and analyses were started to get benefits quantification (as we will see in follow-on briefings); but more work is needed to get broader, more complete sets of answers.

Question: Where would you spend \$200 Million to get collision avoidance?

Answer: Do front-end analyses to understand the technologies and problems; also, seek commonality across the platforms. Don't build the vehicles yet.

Question: Has there been any quantification of the benefits of cooperative systems?

Answer: Yes, in the following briefings.

Comment: Autonomous is near term; cooperative is long term

Answer: If you just work on autonomous systems, you won't have very meaningful systems in either the near or long term; cooperation is needed to achieve robust systems.

Answer: If the public agencies could guarantee road markers, then vehicle manufacturers could deploy meaningful systems much sooner.

Comment: The On-star and Rescue systems are cooperative systems developed by GM and Ford without any government support.

Answer: The On-star system used the cellular infrastructure that already existed; GM and Ford did nothing to develop it.

3.5 Quantitative Analyses of Cooperative and Autonomous Vehicle-Highway Systems – Jim Misener, PATH

This briefing provided an introduction to the quantitative analyses of cooperative and autonomous systems using the NAHSC modeling and simulation tools. It described the tools and how they correlate to each other, and how benefits are estimated using them.

The briefing charts are contained in Appendix D.

There were no questions.

3.6 Safety Analyses: Cooperative and Autonomous – Datta Godbole, PATH

This briefing described, in detail, the modeling and simulation of the safety of vehicle following; the capacity of cooperative and autonomous systems; and lane changing for specific sets of assumptions. It was pointed out that drivers today have a form of cooperation in that turn signals, brake lights and other indications help warn drivers of the intentions of the other drivers; collision warning and avoidance systems should have similar advantages. An in-depth description of the assumptions was given, including vehicle braking characteristics, the types of cooperation assumed, and the conditions assumed for the roadway. The results compared the probability of collision in a hard-braking emergency for a typical driver, an alert driver, an autonomous vehicle with automatic braking and two types of cooperative vehicles with automatic braking. The results showed that both autonomous and cooperative systems are many times safer than even an alert driver; and that a cooperative systems is about twice as effective as an autonomous system. The presentation also showed that merely dedicating a lane to vehicles with some level of automated control could reduce the likelihood of crashes by 84 percent.

The capacity of cooperative and autonomous systems was also compared for varying sets of assumptions. It showed that cooperative systems have significantly greater capacity capability than autonomous systems, with highly cooperative vehicles in platoons having the greatest capacity potential.

The lane changing analysis was described. It showed that lane changing where there is cooperation among the vehicles is both safer and more efficient.

The briefing charts are contained in Appendix E.

Question: What assumptions were made in the chart that showed cooperative systems to be twice as good as autonomous systems, and 15 times as good as alert drivers?

Answer: Communications from the lead vehicle to the following vehicle at the start of braking; the highly cooperative systems also transmitted braking capability. There were other assumptions as well.

Comment: Someone in the audience stated that there would be no collisions with automated vehicles; this statement was questioned.

Answer: This would be possible if all vehicles were automated, and if there were no “outside” disturbances to the traffic flow.

Comment: The assumption of 3000 vehicles per lane per hour is less than reality; today’s roads (with manual drivers) can support more than that.

Answer: Actually the best that can be achieved with manual drivers is a little over

2000 vehicles per lane per hour.

Comment: Can't assume numbers of crashes using averages; it's the deviations from average where crashes are most likely to occur

Answer: That is correct; that is why the models are run using actual distributions for vehicle braking, human reaction times, etc.

Comment: Low delta-V collisions with a string of vehicles may cause lateral and yaw motions that result in dangerous crashes.

Answer: Yes, that is a concern. Some string analyses have been done at PATH, but the work was completed.

Question: Can the tools be used for modeling the evolutionary introduction of services as mentioned in Roger Fruechte's briefing?

Answer: Yes, for some types of collision avoidance systems.

Question: Can the models be used for various IVI services?

Answer: Yes, for some types of collision avoidance systems.

Question: Is this type of braking data available for heavy vehicles?

Answer: We do not have in-depth heavy vehicle braking data; we do have some data, but the variations due to load, type of tire, size of tire, numbers of tires, etc. we do not have.

Comment: In regard to a chart statement: "We obtain 84 percent reduction in crashes mainly due to lane dedication": it would seem that a comparison with manually driven vehicles on protected lanes is needed so that the percent improvement due to automated control would be known.

3.7 Analyses of Available Information versus Performance – Datta Godbole, PATH

This briefing presented results of some modeling analyses in which the amount of information available to the vehicle control logic was varied from minimal, such as "own speed," to extensive such as the acceleration and braking capability of the preceding vehicle. The result of the analyses was that for the same level of safety, capacity increases with the addition of more information. In addition, comfort would also increase in that the number of false alarms would decrease with additional information.

Some initial information from an incomplete micro-simulation-based adaptive cruise control analysis (ACC). The initial premises were based on the work conducted by the University of Michigan in a field operational test of ACC, and on some PATH traffic data from Hayward, California. The study showed that ACC use can be as high as 98 percent, even in heavy traffic if vehicle cut-in can be prevented. Cut-in can be prevented by either closing the gap between vehicles or by operating on a protected lane where cut-in is not possible. It was concluded that the close gap operation would not be

safe without cooperative information between vehicles. A lane dedicated to vehicles operating with ACC would be effective in increasing safety, and efficiency of traffic flow.

The briefing charts are contained in Appendix F.

Question: The analysis assumed that 100 percent of the vehicles were equipped with cooperative ACC; it is apparent that we will never have 100 percent penetration—what if less than 100 percent were equipped?

Answer: Vehicles would operate autonomously unless other equipped vehicles in the vicinity were detected in which case the equipped vehicles would operate more efficiently. As vehicle penetration increases, the overall efficiency of the traffic flow will increase. Benefits are not dependent on complex cooperative systems requiring inter-vehicle communication; simpler devices such as reflectors would produce benefits; penetration can then increase rapidly for a relatively low investment.

3.8 System Performance for Differing Levels of Cooperation – Jim Misener, PATH

Assumptions were made concerning the use of partially automated vehicles in mixed traffic where some of the vehicles had cooperative capabilities. A basic manual throughput of 2000 vehicles per lane per hour (vplph) was assumed. Assumptions were then made concerning the market penetration of vehicles with a variety of automated capabilities, and the throughput for the varying penetration levels was calculated. The results showed that for autonomous vehicles, little improvement in throughput could be expected until the vehicle penetration is over 50 percent; even then, maximum throughput would be expected to rise to less than 3000 vplph with inter-vehicle spacing of 10 meters. For more normal inter-vehicle spacing, the throughput can actually decrease as autonomous vehicle penetration rises. For cooperative systems, rises in capacity can be noted for penetrations of 30 to 40 percent; and total throughput could be expected to rise to between 3500 and 4500 vplph; the higher capacity is achieved with automated non-uniform spacing between vehicles.

Performance variations were also defined for the Houston Metro case study. Three different scenarios were assumed; these were described. Results were then presented for the various analyses that were conducted—throughput, merge and queuing, and emission and fuel consumption. Results were that longitudinal cooperation is feasible with the Houston Metro case study environment assuming modest infrastructure improvements. The HOV/transit lane capacity could be doubled; but cooperation among the automated vehicles would be needed to handle the higher volumes.

The briefing charts are contained in Appendix G.

Comment: It looks like the chart labeled *CO₂ Emissions* should read *CO Emissions*.

Answer: Chart may be mislabeled; presenter will investigate.

3.9 Tools Status Versus IVI Needs – Jim Misener

This presentation describes the suite of tools developed by the Consortium, and addresses those extensions that need to be made to allow the tool set to fully support IVI.

The briefing charts are contained in Appendix H.

Question: What is meant by “extend SmartAHS for Heavy Vehicles”?

Answer: The characteristics of heavy vehicles, including their emergency dynamics, need to be included in Smart AHS

Question: Can the simulation and analyses tools be used for heavy vehicles?

Answer: Yes, and many of the models exist at PATH. They just have not been implemented into SmartAHS due to lack of funding.

3.10 Lessons Learned from Demo '97 on Cooperative and Autonomous Systems – Steve Shladover, PATH

The presentation gave an overall description of the demonstration including statistics on attendance and rides given. The presentation focused on two of the scenarios in which both cooperative and autonomous operation were demonstrated the Control Transition scenario by Honda team, and the Platoon scenario by the PATH team. For the Control Transition scenario, records of lateral position accuracy were given showing that lateral position was much more accurate with the cooperative system involving embedded magnets than with the autonomous vision system. For longitudinal tracking, the steady state tracking error was comparable between the autonomous and cooperative systems; however, the transient performance of the cooperative system was much better.

The very accurate magnetic marker lateral control for the mini-demo was described; in corners with lateral forces of over .5 g at 30 km/h, the lateral error was less than .2 meters.

There was no comparable autonomous system to compare to. On I-15, the longitudinal control using radar range rate (as in autonomous systems) was compared to the level of control possible when the radar information was supplemented with radio links of precise speed to the other vehicles. The latter was used during tight platoon operation (6.5 meters apart); if the radio link failed, the vehicles moved apart to provide 15 meter separation to account for the less accurate longitudinal position control. The data substantiated the modeling and simulation results showing that cooperative systems have higher accuracy, less sensing noise, better fault detection and data fusion, and more robustness to accommodate component failures.

The briefing charts are contained in Appendix I.

Question: Were the data from the demonstrations fed back into the SmartAHS model?

Answer: No, but other prior test results were fed into the models. There has been

little modeling since the demonstration, but the data is not inconsistent with the model assumptions. The data is, however, at a lot greater level of detail.

3.11 Societal and Institutional Lessons Learned for IVI – Alan Lubliner, PB

This briefing addressed the research conducted on societal and institutional issues by the Consortium. Twelve areas of study had been identified by the NAHSC; there had been progress made in ten of those areas by the time work was halted. Most of those ten areas are relevant to IVI. The potential for automated vehicle control services in transit were discussed, and several examples for potential demonstrations were given. Processes for collecting user needs were discussed as were approaches for cost/benefit tradeoff analyses. Finally, potential licensing, inspection and enforcement issues were addressed for IVI.

The briefing charts are contained in Appendix J.

Question: What does “precision docking” mean?

Answer: Refers to the automatic positioning of a bus (laterally and longitudinally) at a docking station or bus stop so that the tires do not scuff the curb and the doors are positioned accurately for passenger entry and exit; this includes “roll-on” entry of wheelchairs.

Comment: The reduction of stress predicted relates to the level of automation, not whether the automation is cooperative or autonomous.

Answer: Correct.

Question: Did the driver license analysis include commercial drivers?

Answer: In some states it did.

3.12 Agency Issues and Concerns – Alan Lubliner, PB

The concerns in deploying, owning and operating roadway facilities that are dedicated to the operation of fully automated vehicles were addressed in this briefing. It was pointed out that the conclusions would also apply to the operation of dedicated lane facilities for partially automated vehicles as well. Thirteen state transportation agencies were surveyed for this study. They identified twelve areas of concern:

- Incremental deployment path
- Local priorities amidst high level goals of the area
- Safety as an advantage for dedicated lanes
- Interface with non-dedicated roads
- Relationship to traffic management centers
- Transit operations on the facilities
- Special fleets on the facilities
- Relationship to planning and economic development
- Liability
- Deployment process
- Public/consumer acceptance
- Other costs and benefits

The presentation also covered some follow-up interviews with some of the transportation agencies concerning their initial impressions of autonomous and cooperative systems. The results were varied with no clear pattern.

The briefing charts are contained in Appendix K.

There were no questions or comments.

3.13 Case Studies – Greg Larson, Caltrans

The NAHSC conducted several studies of the applicability of AHS services in local areas in conjunction with the local transportation authorities. These were called “case studies.” Three of the Consortium’s case studies were described: Western Transportation Institute (WTI), Minnesota Department of Transportation, and the Southern California Corridor. The First NAHSC case study at Houston Metro was addressed in the *System Performance for Differing Levels of Cooperation* presentation.

Each of the three case studies was different; the WTI study was of a rural area where safety was the predominant concern; the Minnesota study was of the specially equipped snow plows; and the Southern California Corridor was of a major urban area where the predominant problems are congestion and air quality. The primary conclusion of the presentation was that case studies are very useful because it forces the implementor (e.g., IVI) to focus on specific, real transportation problems in a real environment. Other conclusions were that case studies should be used for IVI; the regions that co-sponsored case studies with the Consortium are innovators and should be considered for IVI; and the NAHSC case study procedure was very successful and should be considered by the IVI.

The briefing charts are contained in Appendix L.

Question: At WTI, was congestion within Yellowstone Park addressed? This is a major problem for the National Park Service.

Answer: No; just the congestion outside of the park was addressed by the states.

Question: Does the USDOT have any plans to include case studies in IVI ?

Answer: Not at this time.

Question: What percent of the NAHSC funding was earmarked for case studies?

Answer: The original plan was to earmark about \$30,000 each as seed money for five or six case studies.

Question: Should case studies be considered in conjunction with the field tests that may be part of IVI?

Answer: Yes; the case studies are the necessary preliminary steps that need to be covered before a successful field test can be conducted; it gets the local transportation agency on-board with the effort; it helps set goals, and it gives direction to the proper conduct of the field test.

3.14 Liability Issues – Janie Blanchard, Bechtel

This presentation provided an overview of the liability Workshop that was jointly sponsored by the NAHSC, ITS America and the American Association of State Highway Transportation Officials (AASHTO). The workshop concluded that there is significant safety and economic benefits possible with automated systems. Competition is seen as the biggest present barrier to deployment of systems, but fear of liability is a serious issue.

However, it was concluded that if the new system enhances roadway safety, then real liability issues may be expected to decline even though the degree of liability may shift among the parties (driver, manufacturer, and highway owner).

The briefing charts are contained in Appendix M.

Question: Is there any output from your effort that can be useful for planning our operational tests? For example, how about insurance?

Answer: We only had a few insurance company representatives at our workshop; they are used to working with detailed data, not planning information. However, we dealt with insurance companies during the '97 Demo.

3.15 Understanding and Involving Stakeholders – Roger Boothe, PB

This briefing was a video presentation. It presented some of the conclusions from the Consortium's stakeholder relation effort. Conclusions included the following:

- Each stakeholder has different needs and viewpoints; for example, insurance companies need detailed results of testing and performance
- Keep the stakeholders informed
- Get them involved
- Thank them for any input

- Show them that their input has an impact
- Make it cheap and easy for them to join—go to them
- A cooperative vehicle-highway system may lower cost and improve reliability

The briefing charts are contained in Appendix N.

Question: Who developed the tool that was used?

Answer: Boone-Jones, a subcontractor to Lockheed Martin, and Bechtel.

3.16 Needed Human Factors Research – Bob Hogan, Raytheon

Initially the USDOT had directed the NAHSC to not study human factors because they had a separate human factors contractor. When the results from that contractor became available, it was evident that significant additional work was needed. The Consortium began an investigation of some of the primary human factors issues. This presentation summarizes those investigations. The driver Role Team identified three major issues: inattentiveness due to lessened driving involvement; roles confusion; and transfer of control/rapid driver intervention. In all three areas, additional study was planned prior to when the work was discontinued; however, preliminary results were given. For driver inattentiveness, a study showed that head nodding activity increased with time on task and with degree of automation. It was believed that some of this may be attributable to Micro-sleep; more study is needed. Roles Confusion was the central theme of both a directed literature review and a human factors assessment of two background collision avoidance concepts. Transfer of Control scenarios had been postulated and potential issues identified; however, work was terminated before any results were available.

The briefing charts are contained in Appendix P.

Question: Can you relate your information on driver inattentiveness to other studies on eye movement? How would percent of eye closures relate to head nods? Is it more accurate?

Answer: It would be a worthy examination to compare head nods to studies using the Electrooculogram (EOG).

Comment: Inattentiveness is broader than drowsiness.

Answer: Agree.

Question: What is a “background Collision Avoidance System”?

Answer: A system that does not provide control until it is needed to avoid a crash.

Question: Your concern was that the driver is allowed to over-ride the system, for example, if the driver is being warned that he/she is inattentive. Can you envision a system that doesn’t require intervention at some point?

Answer: It is unwise to require that disengaged operators suddenly intervene in

critical situations. Sufficient levels of automation and reliability would lessen the need for sudden intervention.

Question: Have you studied the human capability to respond to warning alerts under various situations?

Answer: No. However, like systems that introduce any degree of vehicular control, warning alerts should be evaluated in terms of the driver's time to understand and react to the full traffic situation versus the critical time that the traffic situation allows.

3.17 Critical Enabling Technologies – Chuck Thorpe, CMU

The Consortium's approach to research on critical enabling technologies (CET) was presented. The CETs were defined and prioritized based on perceived needs of future systems. Research teams were then formed for each of the high priority CETs. The categories of research were:

- On-vehicle sensing
- Roadway and infrastructure sensing
- Actuators
- Communications
- Processing
- Algorithms
- Infrastructure and Configuration

Ten fundamental problems to be solved by partially and/or fully automated systems were then defined. Charts were presented that showed a strong correlation between these problems and the 26 IVI services. Each of these problems was then examined, and the technologies that would help solve the problem was discussed. Finally, the NAHSC research efforts were correlated to the problems, and pictures, graphs and charts showing some of the results of the relevant research were presented. Recommendations regarding further research for IVI were made. The problems are:

- Know where other vehicles are
- Handle obstacles
- Know vehicle location in the lane
- Control the vehicle
- Know absolute position while moving
- Know vehicle braking capability
- Know other vehicle movement and intent (vehicle-vehicle communications)
- System reliability
- Avoid clutter in environment
- Miscellaneous (actuators, entry and exit, driver condition monitoring, etc.)

The conclusions of the presentation were that the vast majority of the NAHSC CET research is directly applicable to the IVI, and much of it is promising. NAHSC made significant progress, but most of the research efforts are unfinished. "Significant

challenges continue to face IVI, but there is a danger of losing momentum, data, apparatus and people to do the research. The biggest challenges are in:

- Obstacle detection
- Predicting braking capability
- Separating returns from clutter
- System reliability
- Human factors

The final conclusion was that some functions can be done autonomously; however, cooperation, even passive, will help perform many of the critical functions, and at the least, enhance autonomous operation when it is possible. It is not a question of autonomous versus cooperative, but what degree of cooperation is best.

The briefing charts are contained in Appendix Q.

Question: Did you consider IR detection (e.g., of pedestrians) and data fusion of that data with radar or vision?

Answer: Only for obstacle detection systems. Rain interferes with IR, since everything is basically at the same temperature.

Question: Has detection of potholes been examined?

Answer: It is difficult to detect distance to such obstacles due to the nature of the technologies employed.

Comment: It is important to select the standards that can accommodate needs well into the future.

Question: How well were communications requirements defined?

Answer: At a top level only except for the communications used in the demonstration.

Question: Wasn't reliability addressed in the AHS demonstration by utilizing the operator as a backup?

Answer: Partially; redundancy was used in the critical systems of scenarios so that if a system failed, the vehicle kept operating in a reduced capability mode. But the trained operator was the ultimate backup. Until systems become more reliable, the driver may need to be the primary responsible party.

Comment: Reliability must be addressed as a system problem.

Comment: there may be an opportunity in Pennsylvania to address the problem of roadside clutter (i.e., Sensor Friendly Highway concept) since they are re-doing their roadways statewide.

Comment: the cost estimate for reflectors can be much less than the cost that was

presented. For example, there are only 600,000 bridges in the U.S., and roughly 300,000 miles of roadway carry about 60 percent of the nation's traffic.

Comment: The tradeoff between systems located on vehicles and systems on roadways needs to be examined.

3.18 Market Packages for Cooperative Systems – Carol Jacoby, Raytheon

The Consortium had an effort to help define how the vehicle-highway system could evolve from today to full automation. It was seen that this transition would most likely be through the more near-term collision avoidance services. It was also seen that this evolution needed to be consistent with, and in the terms of, the National ITS Architecture.

This presentation described the work done in defining the possible services that might be in the path of transition to full automation, and then the market packages that would most logically support that transition.

Altogether, 93 market packages were defined; each market package responds to different situations such as frontal collision avoidance, side collision warning, etc. Many of these could be either autonomous or cooperative, depending on the availability of the enabling technology, and many can include levels of control ranging from warning through partial control to full control. Many of the market packages could be considered “Generation 1” IVI in their initial phases.

This briefing also discussed the role of cooperation—what does cooperation add to a service? It was pointed out that many situations on today's roads require cooperation of some type to provide warning and/or forecasting of conditions that cannot be detected autonomously. This was discussed for several of the market packages that most directly relate to IVI. It was concluded that a small degree of cooperation can have a big payoff.

The briefing charts are contained in Appendix R.

Question: The statement that easing the driver's workload will cause driver inattention was challenged.

Answer: Agreed that there is not enough data in this area, and changed the statement to “may” cause inattention; it is strongly suspected but not yet proven.

Question: Regarding “easing driver's workload causes inattention,” aren't there major human factors considerations involved; for example, since the systems may allow the driver to perform other tasks such as reading while “driving”?

Answer: Yes. One of the major challenges is how to regain the driver's attention before turning control of the vehicle back to him/her.

Comment: Some of the driver's workload is discretionary. Also, the evolution of workload assumption by the system may not be smooth, but may evolve in steps instead.

This is now being measured for ACC. In short, there may be a relation between

workload and driver inattention, but we don't know that it is causal.

Question: Is there any connection of automation to driver inattentiveness for today's cruise control?

Answer: Some anecdotal. The ACC test is looking at regular cruise control versus adaptive cruise control versus none, so may have some relevant results in a few months.

Question: Was it assumed that increasing the extent to which driver functions are automated will always lead to AHS?

Answer: Not necessarily. However, our analyses have shown that a fully automated system will likely provide the greatest benefits, so it is reasonable to assume that one would increase automation to the point that benefits significantly increase and outweigh the costs of automation.

3.19 Deployment: How Do Progressively Advanced Systems Roll Out Over Time? – Tom McKendree, Raytheon

This presentation built upon the previous Market Package presentation. A premise was that the transition would be incremental and over an extended period of time. It postulated likely paths of transition from today's system to full automation. One of the critical conditions for the transition is availability of the critical enabling technologies—when is it technically feasible to introduce services? A chart was shown that addressed this. Another concern is when would a service's penetration of the vehicle population and infrastructure be reached where there would be significant improvements in overall safety and efficiency. And the "chicken-and-egg" problem was also addressed. Why would buyers purchase a vehicle capable of cooperating with other vehicles or the infrastructure if there are very few opportunities for cooperation because of low penetration. Some approaches to this problem were postulated, and similar situations involving introduction of new technologies was discussed (e.g., cellular telephones).

The presentation concluded that the deployment strategies for collision avoidance services need to be driven by what is possible and what will sell. Even though there is currently no consensus for AHS at this point, there needs to be a long-range goal of full automation to provide direction to the transition path and the research and engineering need to support the transition.

The briefing charts are contained in Appendix S.

There were no questions or comments.

3.20 Arizona's I-10 Intelligent Express Lane – Jim Lewis, Raytheon

The final presentation addressed an effort by the Arizona Department of Transportation to plan for the potential of automatically controlled vehicles on one of their state's

highways. Specifically, as Arizona upgrades highway I-10 between Phoenix and Tucson to meet projected growth, they want to build it so that 20 years from now, it could support automated vehicle movement that would make the highway more efficient. The Consortium conducted a concept study with Arizona; this study included a phased approach, projected benefits and costs, and deployment issues.

The phased approach encompasses the near-term construction of a six-lane highway where today there is four lanes; it is to be designed so that it is expandable to eight lanes by 2020. Two of the lanes will be protected and could be dedicated to vehicles equipped with adaptive cruise control and perhaps lane keeping. In the near term, even unequipped vehicles using the lanes will be safer and should flow more smoothly. The lane encourages automated vehicle control services, but is not dependent on them. And the decision to support fully automated vehicles will not have to be made until 2020.

The briefing charts are contained in Appendix T.

Question: How would non-qualified vehicles be kept out of the protected lanes?

Answer: Initially, the only qualification for use of the express lane would be a willingness to maintain the speed limit, since it is necessary for all vehicles to move at the same speed. Eventually, when justified by demand, only equipped vehicles would be allowed to enter; there could be a sticker on the window of approved vehicles; vehicles entering without the sticker could easily be apprehended along the road by law enforcement.

Question: How would the speed limit be maintained—that is, how would vehicles going either too fast or too slow be detected?

Answer: A Traffic Management System would maintain surveillance of the highway and would be capable of detecting and identifying slow/fast vehicles. Once identified, a variety of law enforcement actions could be taken against these drivers.

Question: Was consideration given to snow and other vehicles?

Answer: There is no snow in the area. There were no exclusions in regards to types of vehicles. Transit vehicles do not operate in the area.

Question: Is there commuter use of the roadway?

Answer: Commuter use is minimal.

4 Discussions

Two general discussion periods were held during the Workshop; one at the conclusion of the first day, and one at the end of the second day.

4.1 First Day Discussions

Jim Rillings, the Workshop moderator, began the first discussion period with a conjecture: *Autonomous forward collision warning systems will not be a viable consumer product in the U.S. in less than 20 years.* He defined “viable” as 20 percent of the new cars sold have the feature.

Burgett: I feel that we will have a system that can meet the technical needs in 10 years, but don’t know about the cost.

Rillings: Do you feel that it could achieve near-zero false alarms?

Burgett: Out-of-path false alarms can be solved; I can’t see why the problem of in-path missed objects can’t be solved by then.

Rillings: My assessment is just the opposite; I think the unsolved problem is out-of-path.

Fruechte: It depends on the definition; it typically takes 20 years to introduce a new technology. We do have an in-path detection system that is satisfactory; it is out-of-path obstacles and clutter that are the problems. And cost (i.e., below \$500) may be a problem too.

Jim Rillings then made a second conjecture: *Limited cooperation with the environment (i.e., the roadway and other vehicles) would make collision avoidance viable within 20 years.*

Burgett: How would you get the cooperative elements in 20 percent of the vehicles or infrastructure in 20 years?

General discussion: The cooperation that could be expected over the next 20 years would be “passive”; that is, simple, inexpensive things such as radar reflectors on the rear of vehicles, and target reflectors on clutter-causing roadside structures such as bridge abutments. It was pointed out that radar reflectors would cost pennies; one inexpensive way for experimentation is to use the bottom of a soda can. It was pointed out that the reflectors would need to be made standard and required. Target reflectors on roadside structures along highways was also discussed.

Resendes: What about vehicles traveling on non-highways?

More general discussion where it was pointed out that even though there are 4 million

miles of roadway, 60 percent of vehicle travel is on less than 300,000 miles of highway. Initially, rural roads with light traffic would not be equipped—that could come later. It was also pointed out that there are 600,000 bridges in the U.S. (rural and urban), so putting inexpensive target reflectors on bridge abutments should not be an onerous task. At \$10 each, that would only cost \$6 million for the nation.

Fruechte: If the vehicle manufacturers could count on the state and federal governments simply maintaining the painted stripe on the major highways, then the unit cost for a collision avoidance system could be under \$200.

Perrin: Regarding consumer acceptance, NHTSA surveys have shown that most people like collision avoidance and would pay the cost of a stereo system. This includes things such as blind spot detection for backing.

In the general discussion that followed, it was pointed out that the NAHSC also found very high consumer acceptance of vehicle automation, including both partially and fully automated services.

4.2 Second Day Discussions

The discussion period began with an open question and answer session; there were no conjectures to start the discussion.

Resendes: Does the NAHSC believe that IVI will be deployed before AHS?

In general discussion, the following points were raised:

- IVI is a basket of services; some of the simpler services such as backing collision warning will be deployed first.
- More complex services such as forward collision avoidance with some vehicle control may not be deployed before AHS unless (1) there is vehicle and infrastructure cooperation; or (2) operation is limited to protected lanes such as on Arizona's I-10. An AHS assumes a protected lane (and environment) dedicated to AHS operation; that is why an AHS deployment could occur sooner than collision avoidance in mixed traffic.
- The AHS transition planning was assuming that the AHS deployment would build upon earlier collision warning services.

Ferlis: Regarding the NHTSA light vehicle operational test, could the Consortium do the operational testing?

Answer: Yes.

Meinert: Why is the USDOT involved in development of vehicles when there is no infrastructure involvement? Isn't this the role of the individual vehicle manufacturers?

Burgett: USDOT is interested in solving a problem, not product development. There are 40,000 traffic deaths yearly and 6 million crashes; the government has a role in

understanding how technologies and partnerships might work to improve this situation.

Fruechte: Vehicle manufacturers are looking at near term; they are not addressing the long range goals and technologies; the USDOT focus should be to lead that effort.

Burgett: The USDOT is looking at how advanced kinds of technologies may solve problems.

MacGowan: If USDOT sees a problem, then we need to take action to help solve the problem. Part of it is helping to create consumer acceptance.

Misener: Why has the pendulum swung from concerns about congestion and safety to just safety? Shouldn't IVI be more balanced?

MacGowan: Disagreed that the pendulum had swung.

Burgett: Arizona is just concrete, so it is not really AHS.

Lewis: Initially that is correct; it is a step that will allow evolution to AHS through addition of AHS entry and exit points and communications as needed. The decision point to evolve is in the future.

Smith: The OEMs will build the stuff; the NHTSA will just test it.

Fruechte: But that should be after joint research. There should be a joint definition with industry of the requirements and technologies.

Smith: We asked for your comments in the IVI Request for Information (RFI), and you are welcome to join a working group.

Lewis: There is not enough money going into capacity enhancement.

MacGowan: There is \$8 million per year in my shop alone.

Smith: The light vehicle program will include cooperation.

Rillings: That is good because the NAHSC has been concerned about the IVI program's apparent lack of acceptance of cooperation and partnerships.

MacGowan: What would be an appropriate time frame for IVI R&D to focus on? Five years? Ten years? Twenty years?

Discussion ensued in which the following comments were made. If the need is near term (e.g., forward collision warning) then near term R&D is appropriate. Once a decision is made to build something at GM, then it takes three years to build it. But

long term research is needed to solve the problems that inhibit the fielding of the more advanced collision warning services. There needs to be a statement of long term goals to give direction to the more near term developments.

Lay: What makes safety sell?

The general discussion was that safety is important, but individuals won't necessarily buy it (they may buy a stereo instead) or use it (only 60 percent of people use their seat belts).

Consumer acceptance takes time; for example, ABS has been around for years, but only now are people interested in buying vehicles with it. On the other hand, surveys by both NHTSA and NHTSC have shown that consumer acceptance of collision avoidance is high, and consumers say they will pay for it.

Jim Rillings asked Chuck Thorpe what he thought would be on vehicles in 20 years. This is Chuck's list:

- After-market run-off-road detector systems
- Run-off-road collision avoidance systems with warning when the system is unsure (e.g., on rural roads)
- Frontal collision avoidance (with control) on interstates, but not on rural roads
- Blind spot detectors
- Drowsy driver warning (non-invasive behavior detection)
- Transit vehicles with pedestrian detectors
- Radar reflectors on vehicles and highways, but some will get broken
- Maybe heavy vehicle convoys
- UV headlights cooperating with fluorescent paint stripes for better reflectance
- May be fully automated vehicles on dedicated lanes in a few places (e.g., dedicated bus lanes)
- Limited automation on special vehicles such as steering control for snow plows

Rillings: What kind of sensors would be on the vehicles?

Thorpe: Not settled yet.

Stevens: Would most vehicles have drive by wire for steering, brakes and throttle? And would the vehicle design include a standard Local Area Net?

Thorpe: Probably.

Hartman: For heavy vehicles, there would also be on-board safety checks to transmit to weigh stations.

MacGowan: Form follows function; will need to project what the trip purposes will be in 20 years compared to today.

Rillings: Similarly, the USDOT and private industry need to jointly develop meaningful long range goals for dealing with that traffic 20 years from now.

References

1. National Automated Highway System Consortium (NAHSC), *Schedule and Statements of Work*, 1995, 1996, 1997, NAHSC
2. Stevens, W. B., *Summary and Evaluation of Precursor Analyses for Automated Highways*, March 1995, The MITRE Corporation
3. Federal Highway Administration, *Request for Applications for the Automated Highway System Program, RFA DTFH61-94-X-00001*, April, 1994, USDOT
4. NAHSC, *Final Application in Response to RFA DTFH61-94-X-00001*, July, 1994, NAHSC
5. NAHSC, *Systems Operational Characteristics for the Automated Highway System*, December 1995, NAHSC
6. NAHSC, *NAHSC Technical Feasibility Demonstration Summary Report*, March 1998, NAHSC
7. NAHSC, *C3 Interim Report*, March 1998, NAHSC
8. FHWA, *NAHSC Termination Activities*, February 1998, USDOT

DRAFT
29 June, 1998

**Appendices for the Summary Report of the
Cooperative and Autonomous Workshop
27 and 28 April, 1998, Washington, DC**

**Conducted by
The National Automated Highway System Consortium
For The United States Department of Transportation**

William B. Stevens

Contract Sponsor: Federal Highway Administration
Contract No.: DTFH61-97-C-00040
Project No.: 099718D3-0A

**Mitretek Systems, Inc
McLean, Virginia**

Table of Contents

App.

<u>No.</u>	<u>Title</u>
A	NAHSC Perspective
B	Autonomous Collision Countermeasure Systems
C	How Cooperative Systems Can Help
D	Quantitative Analyses of Cooperative and Autonomous Vehicle-Highway Systems
E	Safety and Capacity Analyses: Cooperative and Autonomous
F	Analysis of Transmitted Information—ACC Analyses
G	System Performance for Differing Levels of Cooperation
H	Evaluation Systems and Tools Status
I	Lessons Learned from Demo '97 on Cooperative and Autonomous Systems
J	Societal and Institutional Lessons Learned for IVI
K	Agency Issues and Concerns
L	Case Studies
M	Liability Issues
N	Understanding and Involving Stakeholders
O	Unused
P	Needed Human Factors Research
Q	Critical Enabling Technologies
R	Market Packages for Cooperative Systems
S	Deployment: How Do Progressively Advanced Systems Roll Out Over Time?
T	Arizona's I-10 Intelligent Express Lane
U	NAHSC Perspective and Accomplishments Report

Introduction

This document contains the separately bound Appendices to report _____, *Summary Report of the Cooperative and Autonomous Workshop*. The workshop was presented by the National Automated Highway System Consortium (NAHSC) to the U.S. Department of Transportation (USDOT) on the 27th and 28th of April, 1998, in Washington, DC. The Workshop goal was to transfer the knowledge gained by the NAHSC regarding cooperative and autonomous systems to the USDOT's Intelligent Vehicle Initiative (IVI) team. The Workshop consisted of a wide range of briefings on different aspects of cooperative and autonomous systems presented by the Consortium.

These Appendices contain the visual briefing materials presented. The briefing materials are in different formats, so no attempt has been made to number the pages. The briefings are, however, in the sequence shown in the Table of Contents.

An “*autonomous*” vehicle system is defined as one that is expected to work reliably without help, regardless of the ambient or external state. A “*cooperative*” system is one in which performance is enhanced through some form of cooperation between the vehicle and other vehicles or the infrastructure; this cooperation could be as simple as reflectors on the rear of all vehicles; or complex as continuous communications between close vehicles or with the infrastructure.

The Workshop covered two full days. The USDOT limited attendance to the government's IVI team and Consortium presenters to help maximize the opportunity for free and open discussions. A total of 36 people attended the Workshop.

Brief introductions were given by both USDOT and NAHSC representatives to set the stage for the Workshop. The state-of-the-art for autonomous vehicle collision avoidance systems was then given followed by a briefing defining cooperative systems and how they might help solve some of the problems faced by autonomous systems. Follow-on briefings then presented detailed analytical and demonstration data that showed what the effect of cooperation might be on autonomous collision avoidance systems. Briefings on topics that cut across both autonomous and cooperative systems were then given on topics such as societal and institutional lessons learned, liability, use of case studies, need for human factors research, critical enabling technologies, market packages, and evolution of collision avoidance systems.

Discussion periods were held at the end of both days so that key points and implications could be discussed. The goal was not that everyone had to agree by the end of the two days, but that the pros and cons of all issues were known and discussed by the attendees.



NAHSC Perspective

Jim Lewis
Monday, April 27, 1998
8:20 am
Appendix A

J Lewis (Perspective)

1

4/21/98

NAHSC History Part 1



-
- **Original goals, drawn from the ISTEA mandate and based on conclusions of PSA work, were:**
 - build a prototype that was fully automated on dedicated lanes
 - why? – because it offered truly significant benefits and was seen to be technically feasible
 - reduces risk of crashes by 50 to 80%
 - 2 to 3 times throughput
 - so stress free the driver may safely go to sleep

J Lewis (Perspective)

2

4/21/98

NAHSC History Part 2



- **Goal of program was changed by FHWA in March 1997**
 - forces for change evident much earlier
- **NAHSC initiated a study of partial automation – warning, temporary control, continuous control (IVI Levels 1, 2, &3)**
- **NAHSC shifted focus**
 - from an AHS prototype
 - through all AVCSS services
 - to near term prototypes and crossing cutting research

IVI Program Issue



- **Balance between Cooperative and Autonomous systems?**
- **Cooperative defines part of public sector role for**
 - vehicle to vehicle communications
 - cooperative highway infrastructure
- **NAHSC has explored cooperative solutions**
 - need for vehicle/highway cooperation in AHS
 - vehicle/infrastructure stakeholder balance of Consortium

Basis for Cooperative Systems



- **Roger Fruechte on difficulties with autonomous systems**
 - sensor detection vs. false alarms
 - which sensed objects are important
 - range and terrain blockage
 - problems with sensing vehicle / road friction

Range of Cooperative Systems



- **Steve Shladover on various cooperative approaches and how cooperation helps**
 - more information, better use of information
 - vehicle to vehicle cooperation
 - infrastructure / vehicle cooperation
 - infrastructure protection

Analysis of Cooperative and Autonomous Systems



- **NAHSC analysis and simulation tools were applied – driver in the loop the main limitation**
- **Cooperation provides smoother traffic flow, leading to reduced emissions**
- **Performance of rear-end crash mitigation systems improved with cooperation**
- **With cooperation, ACC may enhance safety and capacity**
- **Cooperation seems necessary for efficient merging**

Lessons from Demo '97



- **Visitors enthusiastic about all demo systems**
- **Steve will show quantitative results from Demo**
 - **higher accuracy of cooperative systems**
 - **better transient response**
 - **smoother rides**
 - **improved system robustness**

Societal & Institutional



- **Incorporating societal/institutional considerations essential for deployment**
- **Proposals for new services must address:**
 - needs/problems of existing system
 - place in total transportation system
 - local differences
- **Benefits must be tangible, visible, and marketable**
- **Benefit/cost tradeoff analyses need for viewpoints of different stakeholders**

NAHSC Human Factors Research



- **Very serious issues for all systems (autonomous and cooperative):**
 - driver inattentiveness
 - roles confusion
 - ability of driver to intervene
- **Warning systems a challenge**
- **Temporary control systems may be quite limited**
- **Continuous control system might require full automation**

Technology Development



- **Chuck Thorpe on enabling technology development**
- **Most NAHSC work applicable to IVI**
 - vehicle and obstacle detection
 - vehicle/lane position fusion for obstacle detection
 - coefficient of friction measurement
- **Various levels of cooperation can help**
 - reduce clutter
 - vehicle tagging
 - braking communications

J. Lewis (Presenting)

11

4/21/08

Overview of Cooperative Concepts



- **NAHSC identified cooperative versions of most AVCSS services**
- **Deployment strategies to address problems with cooperative systems**
- **A Protected Lane concept developed for Arizona DOT**

J. Lewis (Presenting)

12

4/21/08

Autonomous Collision Countermeasure Systems

Roger Fruechte
General Motors

Definition

An **autonomous vehicle system** is one that is expected to work reliably, without help, regardless of the ambient or external state.

Collision Countermeasure System Features



-
- vehicle stability control
 - adaptive cruise control
 - forward collision warning
 - lane departure warning
 - side / rear collision warning
 - lane keeping
 - enhanced driver information

Main Concerns



-
- reliability
 - survive vehicle environment
 - do intended task correctly
 - e.g. find obstacles but avoid nuisance alarms
 - cost
 - ultimate cost to consumer

components of collision countermeasure systems



-
- sensor suite
 - control actuators / algorithms
 - driver vehicle interface
 - warning
 - information

sensing tasks (for various features)



-
- find objects in forward path
 - forward collision warning / avoidance
 - 150 meter range / various size objects
 - adaptive cruise control
 - 70 meter range / vehicle size objects
 - determine long range forward path
 - forward collision warning / avoidance
 - 150 meters

use of sensor information

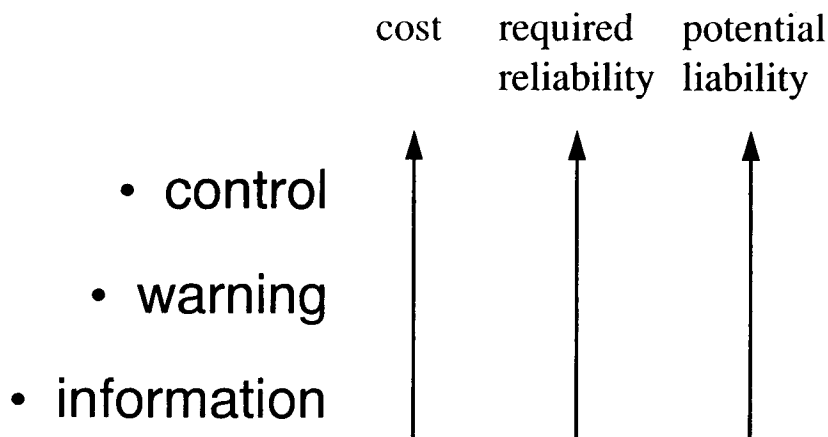

each use has unique problems



-
- control
 - high liability cost => very high reliability required => high system cost / lack of gradual deployment path
 - warning
 - driver reaction time => early detection req'd
 - nuisance alarms / missed detections
 - information
 - cost vs. value to consumer

Difficulties with autonomous sensing



- objects in front, side, rear
 - trade offs in % detection / false alarm rate
 - SOA radar systems give several false alarms per hour at high detection probability levels
 - multi-modal systems (sensor fusion) not mature and add to already high cost
 - estimation of forward path crucial / difficult

Difficulties with autonomous sensing



- objects in front, side, rear (cntd)
 - forward path not 100% predictable
 - driver's actions are not deterministic
 - motion of obstacles not 100% predictable
 - other vehicle driver actions are not deterministic
 - acceleration of obstacles not directly measurable

sensing tasks (cntd)



-
- find side and rear objects
 - side / rear collision warning
 - adjacent lanes / approaching vehicles
 - enhanced driver information
 - find lane position and orientation
 - lane departure warning / lane keeping
 - forward collision warning / avoidance
 - 0.25° orientation when using maps for fwd path

sensing tasks (cntd)



-
- determine vehicle/road surface friction characteristics
 - collision avoidance
 - vehicle stability control
 - adaptive cruise control
 - enhanced driver information

Difficulties with autonomous sensing



-
- objects in front, side, rear (cntd)
 - finite distance of sensors
 - finite field of view
 - can't see around objects or sharp curves

Difficulties with autonomous sensing



-
- forward path geometry / lane position
 - vision
 - visibility limited by darkness / precipitation
 - no assurance of road marking or road conditions (patches, potholes, rogue markings)
 - can't see around objects or sharp curves

Difficulties with autonomous sensing



-
- forward path geometry / lane position
 - GPS
 - position accuracy insufficient without DGPS
 - multiple carrier phase DGPS units required for fwd path orientation accuracies
 - DGPS not strictly autonomous
 - too many dropouts
 - no assurance that maps are accurate or up-to-date
 - e.g. road repair / construction

Difficulties with autonomous sensing



-
- vehicle / road friction characteristics
 - no proven technology for non-contact sensing without creating braking disturbances
 - can only sense conditions as they occur -- (no forward sensing)

Current Federal Programs (on autonomous collision countermeasure systems)



- numerous programs address
 - effectiveness / benefits of these systems
 - performance requirements
 - driver acceptance
- little effort on “Main Concerns”
 - reliability
 - cost

Question



Can cooperative systems help with
some of the above problems?



How Cooperative Systems Can Help

Steven E. Shladover
California PATH Program

Monday, April 27, 1998
9:15 am

Overcoming the Difficulties with Autonomous Sensing



- **Improved information:**
 - more independent information sources (including other vehicles)
 - information beyond sensor range or outside line of sight
 - information that cannot be sensed (intentions)
 - faster information availability
 - more precise information
- **More intelligent use of information**
 - active negotiation of maneuvers
 - opportunity for system-level optimization

Cooperative System Classification



	Passive	Active
Vehicle-Vehicle		
Vehicle-Infrastructure		
Infrastructure Protection		
Other		

SES@NAHSC.4/98

3

Vehicle-Vehicle Cooperation



- **Increases “situation awareness” reliability by providing additional data to augment that from autonomous system sensors**
 - more opportunities for fault management
 - potential for higher nominal performance
- **Facilitates detection of presence, location and identity of other vehicles amid roadway “clutter”**
- **Can be implemented by:**
 - Passive “reflectors”
 - Active communicators

SES@NAHSC.4/98

4

Passive Cooperation Among Vehicles



- **Enables active sensors to easily “see” other vehicles against background clutter:**
 - passive transponders (RF, IR, MMW, etc)
 - distinctive optical patterns (standard sizes)
 - highly reflective vehicle body elements
 - special tags tuned to reflect specific EM frequencies

SES@NAHSC.4/98

5

Active Cooperation Among Vehicles



- **Transmission of important vehicle information:**
 - performance class
 - acceleration, velocity, location
 - failure or hazard notifications
 - adverse environmental conditions
- **Potential cooperative elements:**
 - directional IR, microwave or MMW transmitters
 - low-power RF broadcast transmitters

SES@NAHSC.4/98

6

Infrastructure -Vehicle Cooperation



- **Facilitates sensor identification of lane boundaries, road geometry, and roadside obstacles**
- **Reduces false alarms from roadway clutter**
- **Provides emergency warnings and speed advisories**
- **Can be implemented by:**
 - **Passive markings to highlight or disguise roadway elements**
 - **Active communication transceivers**

SES@NAHSC.4/98

7

Passive Infrastructure - Vehicle Cooperation



- **Identify roadway/lane geometry for vehicle sensors**
- **Identify (or hide) roadside appurtenances to minimize false alarms by obstacle sensors**
- **Cooperative elements could include:**
 - **enhanced lane markings**
 - **enhanced entry/exit markings**
 - **roadside reflectors on curves**
 - **reflectors on off-road obstacles (guard rails, road signs, light posts, bridge structures, trees...)**

SES@NAHSC.4/98

8

Enhanced Lane Markings - Examples



- **Reflective paint stripes**
- **Discrete reflective markers**
- **Magnetic stripes**
- **Discrete magnetic markers**
- **Radar-reflective stripes**

SES@NAHSC.4/98

9

Active Infrastructure - Vehicle Cooperation



- **Communications transceivers to transmit:**
 - **general weather or road surface conditions**
 - **safe speed advisories or commands**
 - **warnings of specific safety hazards (stalls, crashes, obstacles,...)**
 - **warnings of hazards relayed from other vehicles**
- **Active lane reference (current-carrying wire)**

SES@NAHSC.4/98

10

Infrastructure Protection



- **Simplify driving environment by eliminating or at least restricting:**
 - cut-in vehicles
 - debris from other vehicles' crashes
 - dropped loads
 - pedestrians
 - animal intrusions
- **Passive - barriers and fences**
- **Active - entry gates, check-in points**

SES@NAHSC, 4/98

11

Other Cooperative System Technologies



- **Absolute location information from DGPS, combined with:**
 - vehicle/vehicle communication to negotiate cooperative maneuvers
 - accurate roadway geometry database to anticipate roadway geometry changes
 - accurate roadway geometry and roadside appurtenance database to filter out clutter

SES@NAHSC, 4/98

12

Expected Benefits of Cooperative Systems to IVI Services



- **Sensor, Warning and Control:**
 - simplifies sensor signal processing (target identification, tracking,...)
 - provides multiple independent sources of information for data fusion, fault identification
 - provides *earlier* information about hazards
 - provides alternate information sources to continue operation after failure of a primary source (fault tolerance)

SES@NAHSC.4/98

13

Expected Benefits of Cooperative Systems to IVI Services (cont'd)



- **Driver/Vehicle Interface and User Acceptance**
 - higher-performance systems (accuracy, safety)
 - reduced false alarm rate
 - more fault-tolerant system response (higher availability)
 - potentially cheaper in-vehicle systems

SES@NAHSC.4/98

14

Cooperative System Deployment: Technical Considerations



- **No obviously dominant technology, so complementary technologies need to be combined**
- **Passive reflector technologies**
- **Active communication technologies**
- **Minimum performance and interoperability standards are needed**
- **Fault tolerance of technologies and system designs is needed for any system (autonomous or cooperative), but is greatly facilitated by cooperation**

SES@NAHSC.4/98

15

Cooperative System Deployment: Non-Technical Considerations



- **Need effective public/private working relationships to coordinate investments**
- **How to capture vehicle cost savings to provide appropriate deployment incentives?**
- **May need non-standard institutional frameworks to avoid limitations of most public sector agencies (private cooperative infrastructure elements?...)**
- **Public agencies need to consider full life-cycle costs and benefits to justify investments in cooperative elements**

SES@NAHSC.4/98

16

Cooperative System Deployment: Non-Technical Considerations (cont'd)



- Initial cooperative elements should enhance autonomous system effectiveness; as penetration increases, so will overall system benefits
- Many believe that most infrastructure must be equipped before infrastructure-*dependent* collision warning or avoidance systems can be sold for general use
- Need to ensure infrastructure consistency across jurisdictions
- Start deployments with high-visibility “niche” applications with common vehicle and roadway management (snow plows, transit buses,...)
- Need a “leader” to promote cooperative infrastructure across public/private sectors

SES@NAHSC.4/98

17

Appendix D: Quantitative Analysis
Overview (Misener)



Quantitative Analyses of *Cooperative and Autonomous* Vehicle-Highway Systems

Presented by:

Jim Misener and Datta Godbole

Prepared by:

Members of NAHSC Tools (B5) and
Concept/Analysis (C2 and C3) Groups at PATH

Monday April 27, 1998: 10:00am

CVS 4/1998

1

Suggested IVI Matrix



This briefing correlates to IVI in the areas indicated:

<u>AREA OF CONCERN</u>	Rear End	Road Dep.	Passing	Intersect.
	C.A.	C.A.	C.A.	C.A.
<i>Sensing</i>	X		X	
<i>Warning and Control</i>	X	X	X	
<i>Infrastructure</i>	X	X	X	
<i>Driver-Veh. Interface</i>				
<i>User Acceptance</i>	X		X	
<i>Benefits</i>	X	X	X	

CVS 4/1998

2

Quantitative Analyses - Agenda



- **Overview** (*Misener*)
- **Safety Analyses: Cooperative and Autonomous** (*Godbole*)
- **Analysis of Available Information vs. Performance** (*Godbole*)
- **Emerging Results from a Microsimulation (SmartAHS)-Based ACC Analysis** (*Godbole*)

LUNCH

- **System Performance for Differing Levels of Cooperation** (*Misener*)
- **Tools Status vs. IVI Needs** (*Misener*)

Thesis: NAHSC Tools, Analytical Methods, and Results are Readily Applicable



- **We have developed methodologies and an accompanying toolset useful for any vehicle-highway automation concept**
- **Our methodology fuses models and tools with differing granularity and formalisms**
 - producing evaluations, designs, and requirements analysis
- **Our techniques are suitable for evaluating autonomous and cooperative concepts**
 - based on viewing non-cooperative vehicles as sources of disturbances
- **We have a ready-made open architecture microsimulation capability with customizable libraries of vehicle, highway, control systems, sensors, communication devices**

Functions Provided by NAHSC Evaluation Methods and Analytical Tools



- Our *evaluation methods* provide an open and interactive process to
 - match concepts to deployment scenarios
 - prioritize the development of technologies
 - quantify attribute benefits
 - instrumental in trading off and synthesizing concepts vis-à-vis given scenarios
- Our *tools* operate on a library of models generated by government, industry, and academia; they can
 - accept proprietary data in a secure, executable format
 - be used interactively to solve complex vehicle-highway problems

C.W.A. (4/99)

5

Tool Use

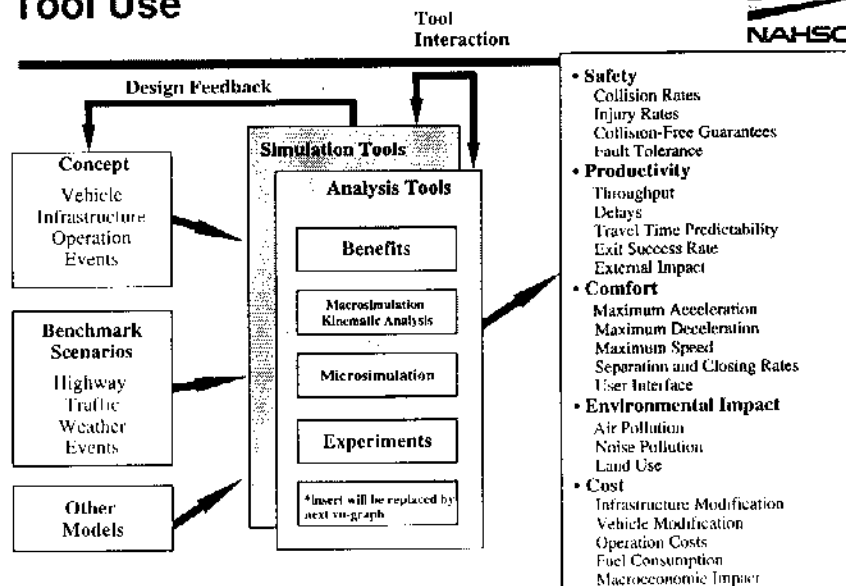

C.W.A. (4/99)

6

Hierarchical Tool Use

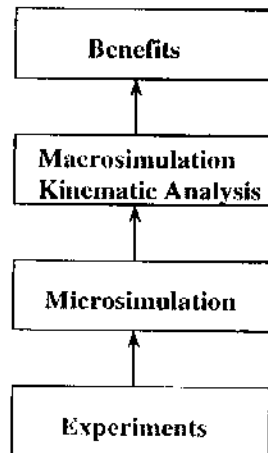

- Crash Probability
- User Acceptance
- Throughput, Travel Time

- Maneuver Abstractions
- Near Miss Probability

- System performance in a given scenario
- Driver Model Calibration Data
 - vehicle following, lane change
 - reaction delays, situation awareness

C vs A (4/90)

7

Extending Prior NAHSC Analyses to Autonomous and Cooperative System Evaluations



- **Analysis tools and methods have been used for**
 - Attribute evaluation
 - *Cooperative and autonomous vehicle following*
 - **Concept evaluation (i.e., system level benefit analyses)**
 - *ACC deployment analysis*
 - *Houston Katy Freeway case study*
 - Design analysis
 - Debug vehicle-roadway automation designs
- **We will report relevant autonomous vs. cooperative systems (*italicized above*) studies and results to**
 - Provide cooperative vs. autonomous insight and conclusions achieved to date
 - Highlight data and analytical needs
 - Illustrate analytical process

C vs A (4/90)

8



Safety Analyses: Cooperative and Autonomous

Presented by:

Datta Godbole

Prepared by:

Members of NAHSC Tools (B5) and Concept Analysis (C2 and C3) Groups at PATH

Monday, April 27, 1998: 10:15am

Outline



-
- Objective
 - Safety Analysis
 - Vehicle Following and Lane Changing
 - Capacity Analysis
 - Single lane highway system with automated longitudinal control
 - ACC Deployment Analysis
 - Conclusions

Objective



- **Identify necessary information for safe, efficient and comfortable driving**
 - The information may be obtained autonomously or cooperatively
- **Quantify benefits of information**
 - Safety, Throughput, Comfort, Emissions, etc.

C-11 A (4/98)

11

Examples of Autonomous & Cooperative Systems



Concept	Autonomous	Cooperative
FCWS	<i>On-board sensor only</i>	<ul style="list-style-type: none"> • V-V LVD warning • stopped vehicle warning V-V, I-V/D
Longitudinal Control System	<i>ACC, ACC with active braking, FCAS</i>	<ul style="list-style-type: none"> • ACC with coop. FCWS • ACC on dedicated lane • Platooning
Lane Keeping Systems	<i>On board sensing only, no active Infrastructure info.</i>	<i>I-V/D excessive speed warning</i>
AHS	<i>Fully automated driving in mixed traffic</i>	<i>Fully automated driving in dedicated lanes</i>
Intersection Collisions	<i>On-board sensing only</i>	<i>V-V/V-I/D-I active warnings</i>

C-11 A (4/98)

12

Benefits of Information



- **Safe driving is based on a *cooperative* relationship between drivers and the roadway environment**
 - Vehicles are equipped with
 - brake lights to mitigate rear-end crashes
 - turn lights to mitigate lane-change/merge crashes
 - flashers to indicate emergencies
 - Roadways are equipped with
 - traffic lights to coordinate drivers
 - speed advisory signs to mitigate SVRD crashes
- **Can *autonomous* systems provide improved safety and/or mobility benefits without considering these cooperative elements?**

CVR A (4/99)

13

Safety Analysis of Vehicle Following



- Consider a vehicle pair
- Given
 - initial speeds & spacing, vehicle braking rate distributions, and sensor/driver delay distributions
- Rear-end collision statistics can be computed
 - assume leader brakes at $t=0$ and follower brakes at $t=d$, where d captures driver reaction time & system delay

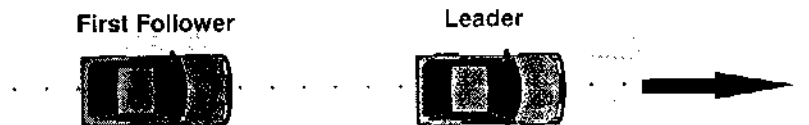

CVR A (4/99)

14

Rear-End Collision Analysis



- **Vehicle pair analysis has been used by NHTSA-VOLPE, REAMACS & NAHSC to estimate benefits of rear-end crash avoidance countermeasures.**
- **Key assumptions**
 - An equipped vehicle is safe from hazards for which unaided manual driver successfully avoids a crash ==>
 - Either one can assume that a driver of an equipped vehicle would still perform all safety critical functions as before, or
 - using above criterion, one can define requirements on sensing, communication, decision making, HMI, actuation and control
 - Drivers respond to warnings as desired
 - Drivers accept the system (do not switch off)
 - Sensors provide perfect detection & no false alarms

CVA A (498)

75

Rear-End Crash Analysis: Strings of Vehicles



- **If the braking rates of the two vehicles are different**
 - can the vehicle-pair analysis results be extended to a string of vehicles?
- **During NAHSC analyses, we have**
 - analyzed strings of vehicles
 - quantified benefits of cooperation & preview
 - used single braking distribution for both vehicles
 - our braking distribution corresponds to *braking capabilities* of new vehicles
 - NHTSA analysis uses braking rates at a stop sign
 - richer data on braking rates of vehicles in different traffic environments is needed

CVA A (170)

16

NAHSC Hard Braking Safety Analysis



- **Inputs: vehicle, driver and system parameters**
 - vehicle operating parameters
 - probabilistic model of braking capability
 - emergency detection delays, brake actuation delays
 - operating speed, inter-vehicle spacing
 - driver reaction time
 - driver/system emergency response strategies
- **Outputs: safety metrics for hard braking scenario**
 - collision velocity distribution for the first collision
 - total collision probability (frequency)
 - mean square collision velocity (severity)

Doc A-14380

17

Braking Capability Distribution for Safety & Capacity Analysis



- **We have collected comprehensive data on new vehicle braking capabilities on dry & wet pavement**
 - using stopping distance (65 mph--> stop) tests by Consumer Reports for new vehicle models
- **Braking capability distribution for Light Duty Passenger Vehicles (LDPV) is created by using North American vehicle sales data for 1994-95**
- **For safety analysis a combined distribution is obtained as follows:**
 - Dry pavement vehicle braking rates are derated by 30% to account for performance degradation due to
 - wear and tear of tires & brake components, change in pavement conditions (wet & dry), etc.

Doc A-14380

18

Braking Capability Distribution

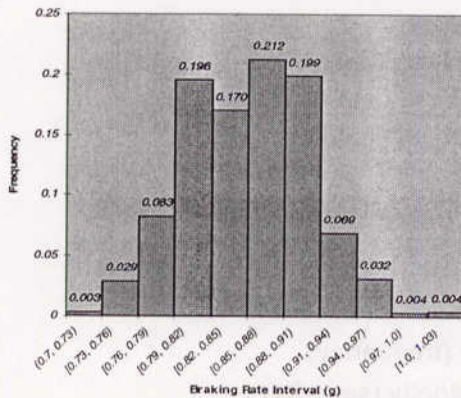

Dry Pavement (LDPV)

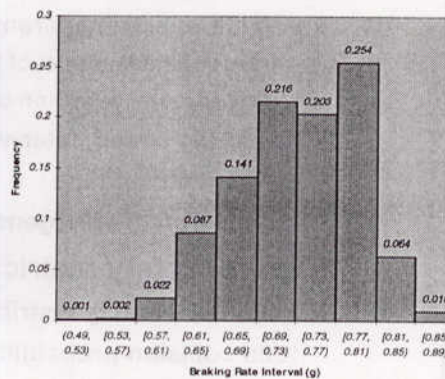

Wet Pavement(LDPV)

C vs. A (4/98)

19

Hard Braking: Response Times for Light Duty Passenger Vehicles



Policy	Sensing/ Comm delay	Actuation delay	Total
Auto. Indv.	200 ms	100 ms	300 ms
Low Coop. Indv	50 ms	100 ms	150 ms
High Coop. Indv.	20 ms	100 ms	120 ms
Platoon Leader	50 ms	100 ms	150 ms
Platoon Follower	20 ms	100 ms	120 ms

- Conservative assumptions regarding
 - communication delays
 - actuation delays

C vs. A (4/98)

20

Modeling Different Levels of Vehicle Automation



- **Autonomous Individual Vehicles**
 - No warning to follower during emergency braking
- **Low Cooperative Individual Vehicles**
 - Vehicles communicate during maneuver coordination and emergencies only
- **High Cooperative Individual Vehicles**
 - Continuous communication between vehicles implies faster warning during emergency braking
- **Cooperative Platooned Vehicles**
 - High Cooperative for intra-platoon following and Low Cooperative for inter-platoon following

C-14 A (4/99)

21

Modeling Braking Action: Lead & Follower Vehicles

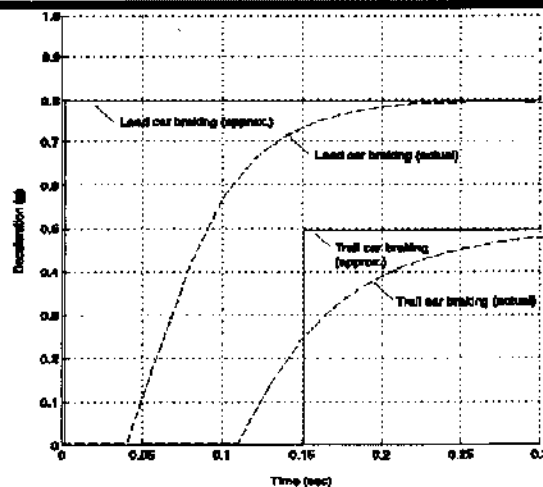

*Conservative approximation of lead vehicle braking

C-14 A (4/99)

22

Unaided Manual Driving Model



- Safety metrics are computed for unaided vehicle following in the hard braking emergency scenario at 65 mph, medium density inter-urban traffic
- Variation In max. braking rates of leader & follower
 - probabilistic model as described
- Inter-vehicle spacing and relative speed
 - probabilistic model obtained from range, range rate data collected during UMTRI FOCAS project
- Delay In detection of hard braking by the follower
 - probabilistic model of driver reaction times obtained from Taoka, ITE Journal, Vol 59, No.3, March 1989
- Brake actuation delays same as equipped vehicles

C. A. (199)

23

Unaided Driver Reaction Time

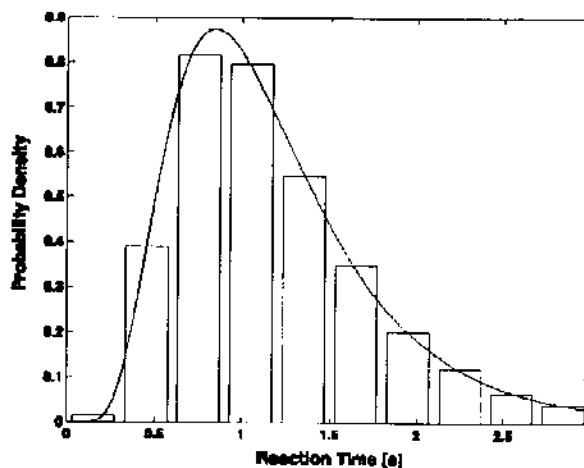

C. A. (199)

24

Results: Collision Velocity Distribution

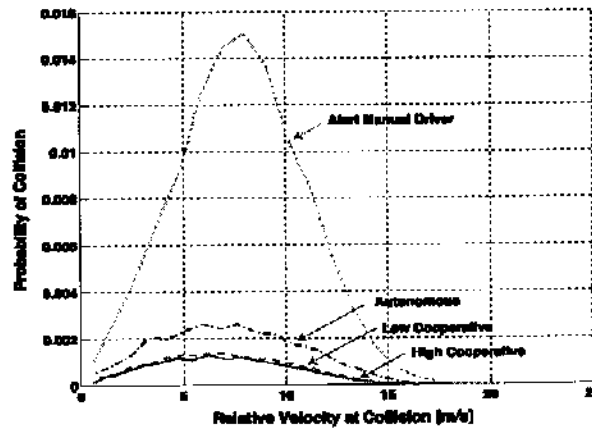

- Rear-end collision probability decreases with inter-vehicle cooperation
- CAS compares favorably with even the fast-reacting alert driver

C vs A (4/90)

25

Hard Braking Emergency Unaided Manual Driving

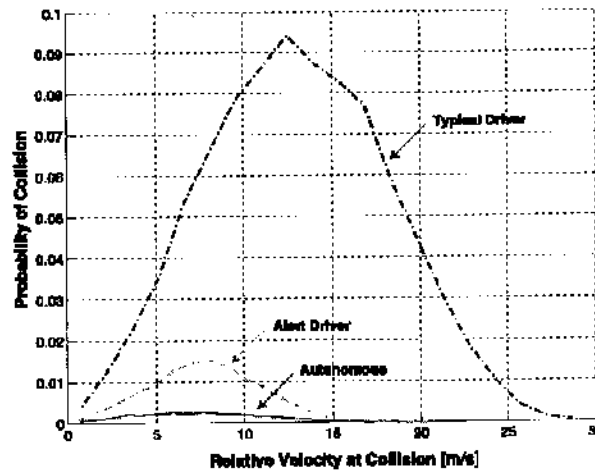

- Reaction time data is not correlated to range and range rate

C vs A (4/90)

26

Benefits of (ACC + FCAS)



- Compare baseline unaided manual driving with 100% penetration of FCAS equipped vehicles
 - Identical environmental conditions & demand levels
- We assume that any string of Rear-End crashes on baseline manual highway is caused by deceleration of the lead vehicle in response to
 - an obstacle appearing on the highway
 - vehicle failure
 - inattentive/careless driver braking hard or causing cut-in disturbances
 - string instabilities resulting in braking amplification
- FCAS can be designed to avoid last two causes of disturbances, in case of 100% penetration

C 13. A (199)

27

Rear-End Crash Avoidance Benefits on a Dedicated FCAS Lane



- Consider a crash causing LVD disturbance for a manual vehicle
- A CAS equipped vehicle would be traveling at
 - less speed, larger range, less range rate, less reaction delay
- Probability of the first crash in this LVD scenario is bounded above by the probability of a collision due to *hard braking disturbance*
 - The deceleration necessary for the following vehicles to avoid a collision decreases along the string
- The above conclusion is not valid for mixed traffic

C 13. A (199)

28

Automated Longitudinal control in a Dedicated Lane AHS



- Consider a uniformly spaced 3000 veh/hr/lane CAS equipped traffic at 30m/s
 - Probability of first collision is bounded above by
 - 4% for autonomous, 2% for low coop & 1.5% for high coop.
 - The probability of *all* possible rear-end crashes in an CAS equipped vehicle string due to an LVD crash causing hazard in manual traffic is bounded above by 4 times the probability of a crash in a pair of vehicles due to hard braking
 - ==> 16 % for autonomous vehicles
- We obtain 84% reduction in crashes mainly due to *lane dedication*
 - inter-vehicle cooperation results in even higher benefits

C. H. A. (2007)

29

Comparison of AHS Concepts: Composite Safety Measure

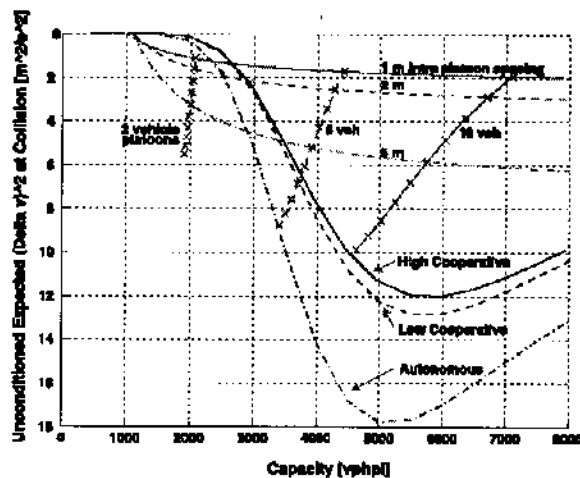

- Inter-vehicle cooperation increases safety
- Cooperative systems provide substantial benefits compared with autonomous systems at higher traffic densities

C. H. A. (2007)

30

Summary of Safety Analyses



- **Conclusions**
 - Inter-vehicle cooperation improves safety of
 - vehicle following & lane changing
 - Substantial benefits are obtained by using structured driving environment, e.g.,
 - highway lane dedicated for equipped vehicles
 - Obtaining system safety benefits from vehicle-pair analysis is not straightforward
- **The analyses have been extended to**
 - account for multiple collisions in a string of vehicles
 - lane change disturbances both during normal traffic and for emergencies such as obstacle avoidance

Capacity Analysis: Cooperative Vs Autonomous



Presented by:

Datta Godbole

Prepared by:

**Members of NAHSC Tools (B5) and Concept Analysis
(C2 and C3) Groups at PATH**

Pipeline Capacity: Single Lane Analysis



- Calculate **safe** vehicle following distances for different attribute combinations such that
 - No collisions in the absence of malfunctions
 - If front vehicle applies maximum braking (In response to a failure), then following vehicle should be able to stop without collision.
 - Low relative velocity Intra-platoon collisions can not be completely avoided in case of hard braking failure.
- Minimum safe inter-vehicle spacing depends on
 - Vehicle initial conditions (speeds & accelerations)
 - Vehicle braking capabilities and reaction delays
 - Information structure:
 - range, range rate, acceleration of vehicle ahead, emergency notification

C 11 A (199)

33

Capacity Analysis: Sensitivity to Parameters



- Spacings are sensitive to braking capability variations among vehicles
- Braking capabilities of vehicles are widely distributed resulting in
 - conservative spacing design for uniform spacing
- Capacity can be improved by
 - Narrowing the width of braking distribution
 - capabilities of vehicles need to be similar
 - Non-uniform spacings:
 - vehicle calculate safe spacing based on *real-time estimation of braking capability* of itself and of front vehicle in case of *cooperative systems*.

C 11 A (199)

34

PIPELINE CAPACITY: 93% LDPV, 6% TRUCKS, 1% BUSES

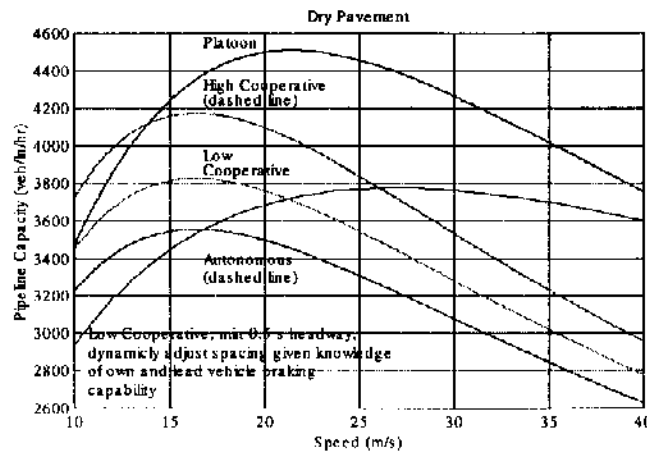

- Capacity increases with increasing level of cooperation
- Platooning results in highest pipeline capacity
- Capacity increases due to knowledge of braking capability

C. Vol. 8 (1998)

35

PIPELINE CAPACITY: 100% Light-Duty Passenger Vehicles

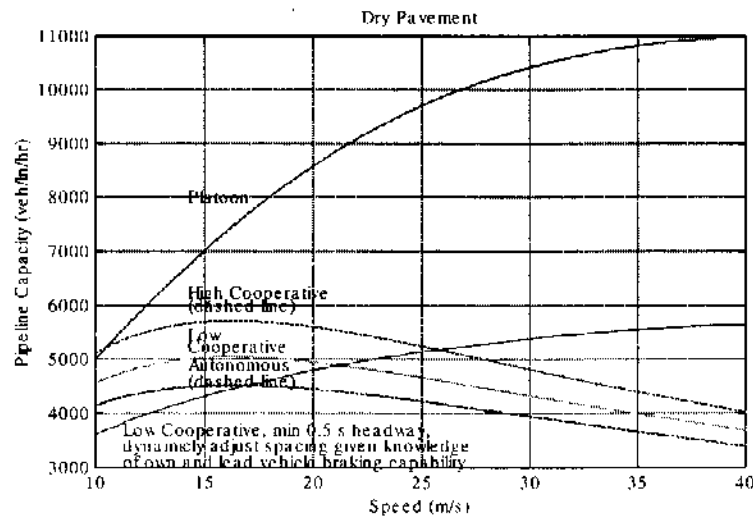

C. Vol. 8 (1998)

36

Pipeline Capacity Analysis Results



- **Capacity increases with level of cooperation**
 - The difference in capacity between dry and wet pavement conditions is less pronounced for cooperative than autonomous vehicles
- **Identification of concepts & technologies for capacity improvement**
 - Real-time adjustment of spacing among vehicles through knowledge of braking rates
 - Excluding vehicles with poor braking performance from use of limited access highways

C vs. A (4/90)

37

Lane Change Analysis



- **Lane change Maneuver involves**
 - Gap selection/creation
 - Alignment
 - Lateral move-over
- **Safe Lane Change:** Vehicle pairs (1,2), (3,1) should satisfy *safe vehicle following* requirements from the beginning of lateral motion.

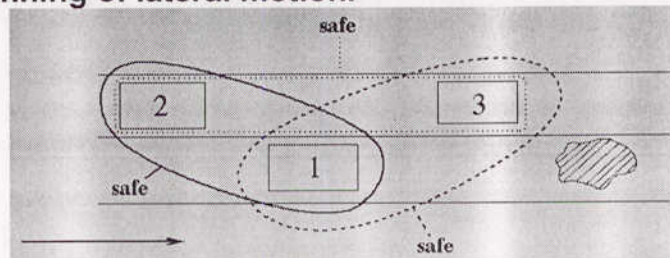

C vs. A (4/90)

38

Lane Change Analysis: Method & Results



- **Spacing design method produces**
 - requirements for safe lane changes.
- **We use optimal control formulation to**
 - design trajectories for executing safe, efficient and comfortable lane change controllers
- **Results indicate that**
 - Inter-vehicle coordination is necessary for safe & efficient lane-change design
 - Communication of intention to change lane
 - Creating a gap to accommodate lane changing vehicle
 - coordinated obstacle avoidance results in substantial safety improvement

Appendix F: Analysis of Transmitted Information (Godbole)



Analysis of Available Information vs. Performance

Presented by:

Datta Godbole

Prepared by:

Members of NAHSC Tools (B5) and Concept Analysis
(C2 and C3) Groups at PATH

Longitudinal Warning & Control: Effect of Information Structure



- **Scenario**
 - Vehicle following, Approaching stopped vehicle
 - Lane change, Respond to cut-ins
- **Different Information Structures: Knowledge of**
 - 1 Own speed only
 - 2 Own speed & Range
 - 3 Own speed & Range & Range Rate
 - 4 Own braking capability + 3
 - 5 Acceleration of preceding vehicle + 3
 - 6 Braking capability of preceding vehicle + 4
- **Method: Calculate the minimum “safe” spacing at which a warning/control action will be executed**

CVS A (4/98)

41

Effect of Information Structure on FCWS and FCAS Design



- **Results**
 - At the same level of safety,
 - capacity increases with more information
 - comfort increases (nuisance alarm rate decreases) with more information
 - Additional information can be obtained by
 - vehicle-vehicle communication
 - estimation of intentions of other vehicles
 - Same results can be obtained by limiting the disturbances that surrounding vehicles can generate
 - e.g., impose operating constraints by dedicating a lane

CVS A (4/98)

42



Emerging Results from a Microsimulation (SmartAHS)-Based ACC Analysis

Presented by:

Datta Godbole

Prepared by:

**Members of NAHSC Tools (B5) and Concept Analysis
(C2 and C3) Groups at PATH**

ACC Micro-Simulation Analysis: Work in Progress



- **Motivation: Results of UMTRI FOT**
 - Driving under ACC is comfortable, but
 - Drivers switch off ACC in moderate to heavy traffic
 - low impact on safety
- **Investigate the effect of deploying ACC in different traffic conditions using SmartAHS microsimulation**
 - Examine safety and system utilization
 - Conventional cruise control suffices at low traffic densities & ACC is switched off in dense traffic
- **Scenario**
 - A string of ACC equipped vehicles follow a manually driven vehicle on I-880 in Hayward, CA.
 - Single lane, no cut-ins

ACC Analysis: Models



• Parameters & Models

- ACC control law by Fancher & Bareket
- Detailed vehicle models
- Lead vehicle speed profile corresponds to a Freeway Service Patrol vehicle
- Driver reaction times modeled as before
- Driver-ACC interface
 - driver switches off ACC when state of the vehicle enters unsafe region
 - safety for each driver parameterized by driver risk taking behavior
 - after taking over control, driver brakes in order to take the state of the system back to safety

C. V. A. (4-99)

45

Driver-ACC Interaction Model

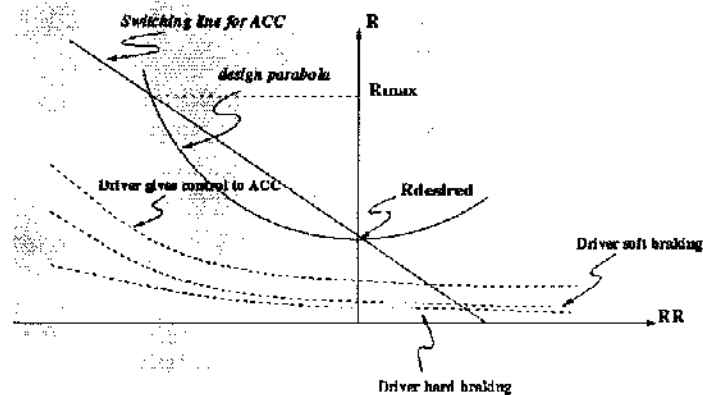

C. V. A. (4-99)

46

ACC Analysis: Results

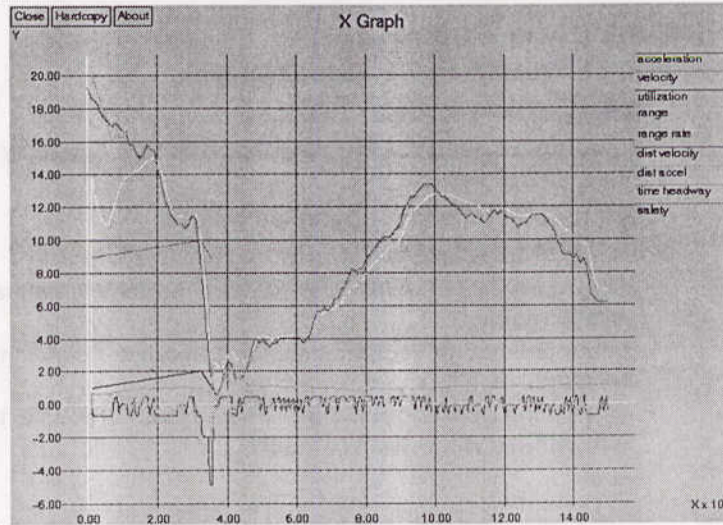

47

ACC Analysis: Results



- Even in heavy stop-and-go traffic, ACC can be utilized up to 98% of time
 - High utilization achieved by eliminating cut-ins
 - Implies infrastructure-vehicle cooperative ACC concepts might yield a beneficial deployment path
 - e.g., ACC only roadways, ACC/HOV lanes
- In a string of ACC vehicles with 0.8sec time gap, crashes were observed further upstream from disturbance-generating lead vehicle
- extra-string-information (*preview*), more than just range-range rate, is required for safety
 - simple vehicle-pair analysis is insufficient for estimating safety benefits of ACC

C vs. A (4/98)

48

Conclusions



- **Dedicated facilities can significantly increase ACC benefits**
 - safety, utilization/convenience, traffic flow
- **Automated longitudinal control/warning in unstructured environment requires preview, situation assessment information**
 - large following distances may result in cut-ins
 - small following distances may experience string instability
- **Inter-vehicle cooperation improves safety, capacity and comfort for control/warning during**
 - vehicle following, lane changing, obstacle avoidance

C 18 A (499)

49

Summary



- **Fully or partially automated driving needs cooperative driving environment with functional equivalents of**
 - signage
 - turn signals
 - brake lights, and
 - preview
- **Cooperative systems provide higher benefits than autonomous systems**

C 18 A (499)

50

Appendix G: System Performance for Differing Levels of Cooperation (Misener)



System Performance for Differing Levels of Cooperation

- "Mixed with Manual" Analysis
- A Real World Example: The Houston Case Study

Presented by:

Jim Misener

Prepared by:

Members of NAHSC Tools (B5) and Concept Analysis (C2 and C3) Groups at PATH

Monday, April 27, 1998: 12:15pm

C 18. A (498)

51

Mixed Automated/Manual Throughput Analysis



MOTIVATION:

In terms of throughput as measure of effectiveness:

- Obtain quantitative differences between concept attributes
 - Dedicated lanes compared with mixed traffic operations
 - Distribution of Intelligence: autonomous compared with low-cooperative
- Obtain quantitative differences under alternative scenarios based on a range in values for
 - vehicle operating speed
 - merge derating factor
 - inter-vehicle safe spacings: uniform vs. non-uniform

C 18. A (136)

52

Mixed Automated/Manual Throughput Analysis



ASSUMPTIONS

- All intelligence is within vehicles
- Manual driver behavior remains unchanged
- Light-duty vehicles only
- Single highway lane
- Random sequencing of manual and automated vehicles on the highway lane

CV 8 A (199)

53

Significant Findings



Fixed parameter values:

- 2000 vphpl manual throughput
- 30m/s operating speed
- 10%-25% merge derating factor
- 0.5s minimum time gap for non-uniform spacing of automated vehicles

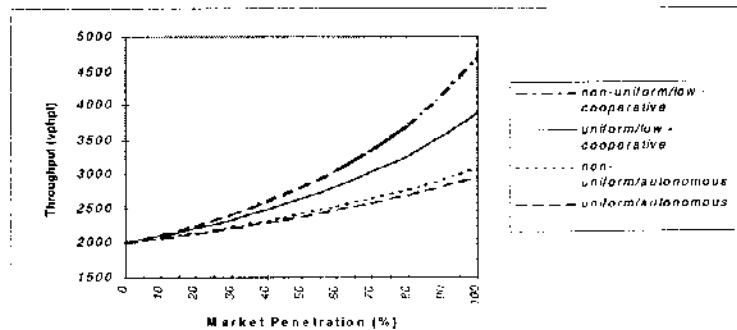

CV 8 A (199)

54

Extension To Parameter Values Representing Autonomous ACC Performance



SENSITIVITY ANALYSIS: CHANGES IN ACC MINIMUM TIME GAP PARAMETER

mp	v=20m/s		v=20m/s		v=20m/s		v=30m/s		v=30m/s	
		dr=0.7	dr=0.7	dr=0.7	dr=0.7	dr=0.7	dr=0.7	dr=0.7	dr=0.7	dr=0.7
AA		21.4	28.6	42.9			28.6	50		
MA		21.4	28.6	42.9			28.6	50		
MM		38	38	38			67	67		
AM		38	38	38			67	67		
		AA gap=10m AA gap=15m AA gap=25m				AA gap=15m AA gap=30m				
0	0	2842	2842	2842	0	1612	1612			
0.05	0.05	2906	2878	2824	0.05	1659	1633			
0.1	0.1	2972	2914	2806	0.1	1710	1654			
0.15	0.15	3041	2952	2788	0.15	1764	1676			
0.2	0.2	3114	2990	2771	0.2	1821	1698			

SUBSTITUTE FOR NEW FILE

"Mixed With Manual" Conclusions



General

- Throughput increases with increasing market penetration
- Increases occur at different rates
- Non-uniform spacing yields greater throughput than uniform
- Low-cooperative yields significantly greater throughput increases for each market penetration relative to autonomous
- Substantial market penetration of automated vehicles is required before appreciable throughput increases can be achieved

Autonomous ACC

- For time gaps associated with ACC, throughput could be reduced up to approximately 14% and 38% for 1.4s and 2.0s (values of minimum time gap parameter), respectively, as market penetration grows toward 100%

A Real World Example: The Houston Case Study



OUTLINE

- Objectives
- Case Study Area Overview
- Alternative Scenarios
- Approach
- Common Assumptions And Inputs
- Findings
- Conclusions and Generalizations

Objectives



- **Houston Case Study:**
 - Ascertain system performance impacts for different levels of cooperation of automated travel in a real-world setting (I-10/Katy Corridor)
 - Investigate the relationship between forecasted travel demand and infrastructure configurations for alternative automated vehicle-highway system concepts
 - Assess emissions levels for various pollutants
- **Beyond the Houston Case Study:**
 - Address "cooperative vs. autonomous" issues in a real-world setting that will provide the basis for future analyses

Case Study Area Overview (Current Configuration)

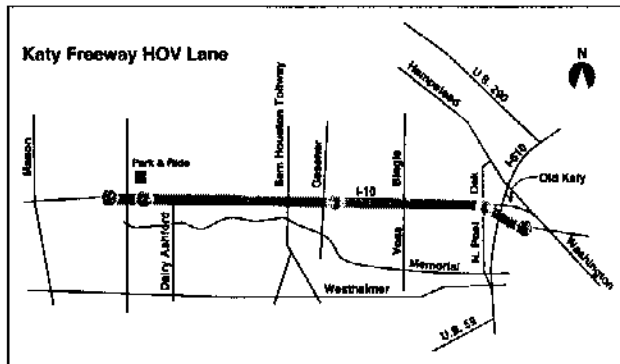

- 1 = Western Terminus
- 2 = Addicks P&R
- 3 = Gessner Slip Ramp
- 4 = Post Oak Access/Egress
- 5 = Eastern Terminus
- 12-mile portion of Interstate 10
- 1 reversible, barrier-separated HOV lane
- 96/4% split (light-duty passenger vehicle/bus)

Case A (1/04)

59

Alternative Scenarios



- **Current HOV configuration**
 - One lane reversible (AM/PM)
 - Barrier separated
 - Three entry & exit points
 - Slip ramp transitions from non-HOV lanes and T-ramp Park & Ride
- **"Build" Scenario 1 (low demand)**
 - Maintains single reversible lane
 - Provides feeder lanes at termini
 - Extends transition/merge lanes at entry/exit points
 - Demand at busiest on-ramp: 300 (ramp), 1450 (mainline)
- **"Build" Scenario 2 (medium demand)**
 - Two-way operation, one lane/direction
 - Extends feeder lanes at terminal and transition lanes at entry/exit points
 - Replace slip ramp with T-ramp Park & Ride
 - Demand at busiest on-ramp: 500 (ramp), 2500 (mainline)
- **"Build" Scenario 3 (high demand)**
 - Two-way operation, one lane/direction
 - Expands feeder lanes
 - Modify T-ramp configuration to allow direct frontage road access
 - Demand at busiest on-ramp: 1000 (ramp), 2900 (mainline)

per lane per hour

per lane per hour

Case A (1/04)

60

Approach



- **Multiple models/simulation tools used in sequence of successively more detailed stages of analysis:**
 - Fed back results to previous stages for consistency
 - Built results from earlier to successive stages
 - Studies of both single access point and full corridor
 - **Single access point analysis** focused on maximum travel demand location along corridor
 - Throughput/travel demand comparative analysis
 - Merge and queuing analysis
 - **Corridorwide investigation**
 - Activity-based capacity analysis (SmartCap)
 - Microsimulation-based merge, emissions, and fuel economy analyses (SmartAHS)

Common Assumptions And Inputs



- 30m/s operating speed
- Vehicle length: 5m (light-duty passenger vehicle), 12m (bus)
- Platoon size: 10 (light-duty passenger vehicle), 3 (bus)
- Platoons are of homogeneous vehicle class
- Intra-platoon vehicle separation: 2m (light-duty passenger vehicle), 4m (bus)

FINDINGS FOR THROUGHPUT/TRAVEL DEMAND COMPARATIVE ANALYSIS



Objective:

- Analyze relationship between alternative concepts and scenarios

Approach:

- Derive inter-vehicle spacings required to satisfy demand and compare with minimum inter-vehicle safe-spacings for each concept

Added Assumptions and Inputs:

- Total demand level (vehicles per hour) for each scenario at busiest access point:
 - Low: 1750; Medium: 3000; High: 3900

Findings:

- All concepts satisfy the low demand level even with uniform spacings
- Only autonomous does not satisfy medium demand level
- Autonomous can be made to satisfy medium demand level by truncating an additional 8.2% off low end (vehicles with poorest braking capability) of braking rate distribution for light-duty vehicles; no change for buses
- Low cooperative requires non-uniform spacing to satisfy high demand level
- High cooperative and platooning satisfy high demand level even with uniform spacings

FINDINGS FOR MERGE AND QUEUING ANALYSIS



Objective:

- Analyze merging & queuing requirements for all three scenarios

Tool:

- Aggregate vehicle simulation tool

Measure of Effectiveness:

- Length of space needed to enter automated lane
Potential Actions: decelerate, queue, accelerate, merge

Added Assumptions and Inputs:

- Demand level (vehicles per hour) for each scenario at busiest access point:
 - Low: 300 (ramp) 1450 (mainline)
 - Medium: 500 (ramp) 2500 (mainline)
 - High: 1000 (ramp) 2900 (mainline)

FINDINGS FOR MERGE AND QUEUING ANALYSIS



**Needed entry ramp
length decreases
with increasing
levels of cooperation**

Findings:

- For autonomous, length grows with demand; infeasible at high demand
- Non-uniform does better than uniform
- Low to medium demand transition involves infrastructure configuration changes leading to decrease in required length
- Cooperative & Platooning yield same required lengths for low & medium; generally preferred for such demand levels
- Results based on a particular check-in procedure to allow comparison across concepts; other check-in procedures result in **significantly smaller** required length for cooperative and platooning at low demand level (- 0.3 - 0.5 km)

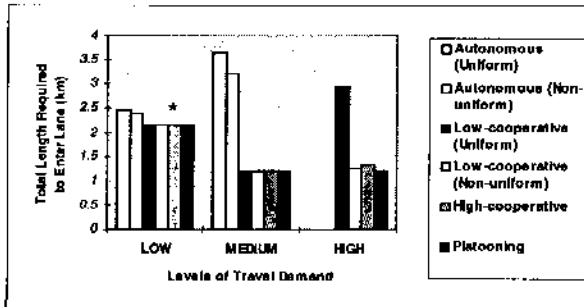

C VL A (4/00)

65

Emissions and Fuel Consumption Analysis



SmartAHS (Houston METRO Scenario, Modal Emissions Analysis) → Emissions and Energy Use

- Capitalizes on emerging results from NCHRP Project 25-11
 - develop a modal emissions model for light duty vehicles to replace EPA MOBILE and CARB EMFAC
 - calibrated on dynamometer/tail-pipe measurements from approximately 300 in-use vehicles
 - accurately include speed, engine load, start conditions, comprehensive driving characteristics, vehicle technologies, various states of condition (e.g., properly functioning, deteriorated, malfunctioning)
- For Houston Metro, all vehicles were 1996 Buick LeSabres

C VL A (4/00)

66

Emissions and Fuel Consumption Analysis (Cont'd)



- **Process:**
 - Used SmartAHS microsimulation to determine (second-by-second velocity and acceleration) trajectories for every Buick
 - Cooperative vehicles
 - Platooned vehicles
 - platoon merge
 - 5 m inter-vehicle spacings
 - Used real traffic data to obtain trajectories for manually-driven Buicks
 - Autonomous vehicles
 - Operated on results with SmartAHS model emissions module to obtain average fleet emissions and fuel consumption

C vs A (199)

67

Fuel Consumption Results

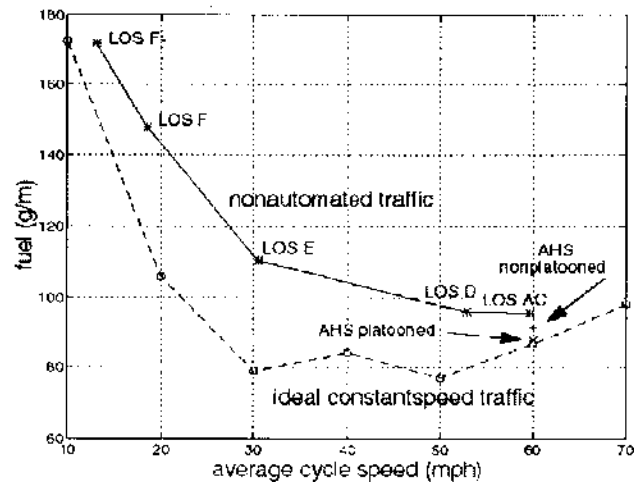

C vs A (199)

68

CO₂ Emissions Results

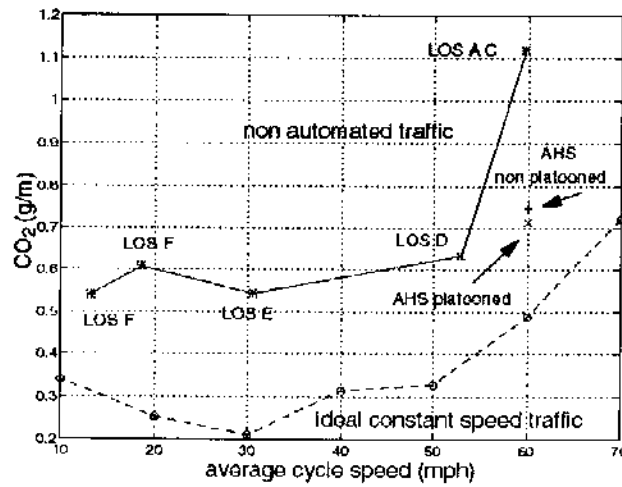

CV 4 (6/99)

69

NO_x Emissions Results

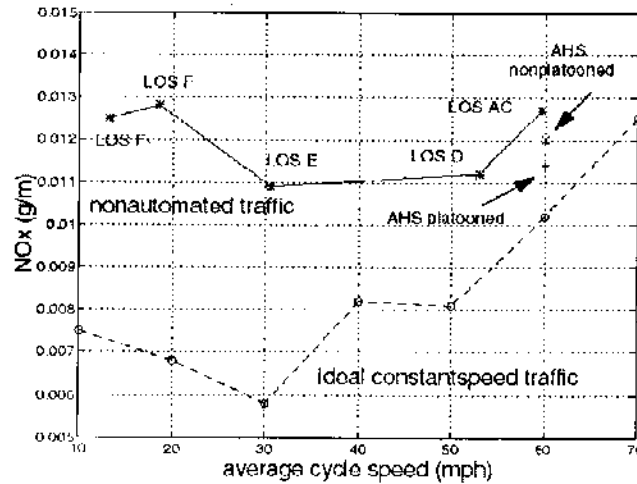

CV 4 (6/99)

70

FINDINGS FOR EMISSIONS AND FUEL CONSUMPTION ANALYSIS



- **Operations with longitudinal cooperation between vehicles consumes less fuel because of smoother traffic flow**
- **Longitudinal cooperation allows lower emissions because of smoother traffic flow**
 - **At 60 mph, lower emissions per VMT for longitudinally cooperative systems than manual highways**
- **Platooning yields an additional 5 - 15% fuel savings due to aerodynamic drafting, depending on intra-platoon spacings**

Emissions and Fuel Consumption Analysis (Cont'd)



- **Potential Areas of Future Work**
 - **Include other vehicle makes, models and classes**
 - **Address different levels and methods of cooperation**
 - vehicle-vehicle, vehicle-roadside
 - apply analysis to different sites and scenarios
 - **Use of variable vehicle spacings**
 - **Potentially, integrate modal emissions analysis with detailed driver models**
 - to the fidelity of human throttle and brake control models

FINDINGS FOR VEHICLE ACTIVITY-BASED CAPACITY ANALYSIS



Objective:

- Study highway capacity for automation concepts along all three "build" scenarios

Tool:

- Meso-scale simulation vehicle-highway tool (Smart Cap)

Measures of effectiveness:

- Vehicle speeds, average queue wait-time, average travel time

Finding:

- Trip Time decreases with Increased Information

C 19 A (199)

73

Travel Plus Queue Time During the AM Commute

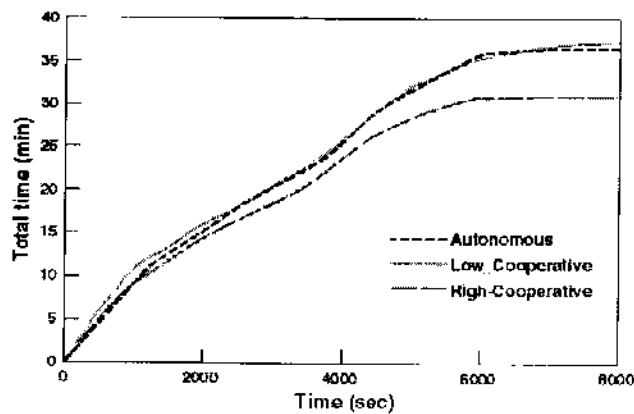

C 19 A (199)

74

FINDINGS FOR SmartAHS MICROSIMULATION MERGE ANALYSIS



Objective:

- Study throughput performance across merge junctions (interaction effects) for automation concepts among all three "build" scenarios

Tool:

- Vehicle-highway microsimulation tool (Smart AHS)

Measures of effectiveness:

- Length of space needed to merge into AHS lane, level of traffic density between junctions

Findings:

- Automated merge controller developed
 - shown to minimally disrupt main line traffic flow
 - potentially extendible to generalized, coordinated lane change control design

CVS A (1/04)

75

Merge-Assist Controller Developed for Fully Automated AHS

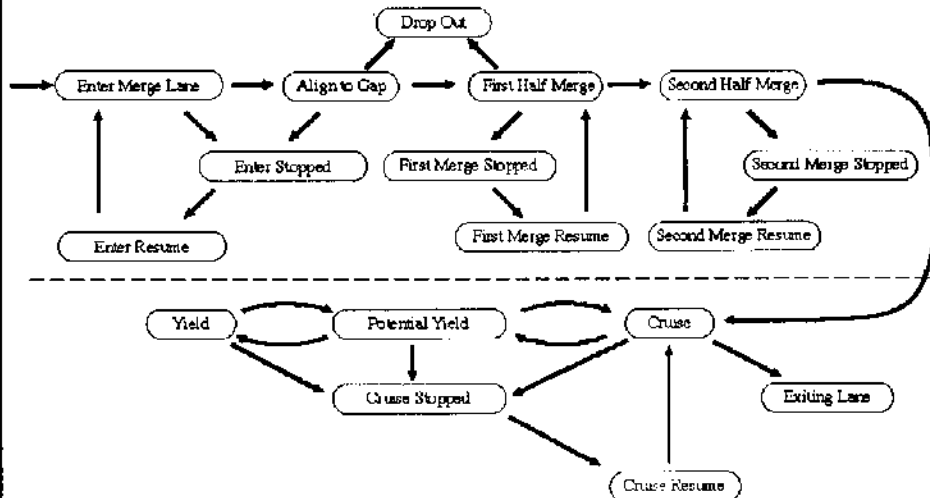

CVS A (1/04)

76

Automated Merge Control Resulted in Minimal Flow Distribution

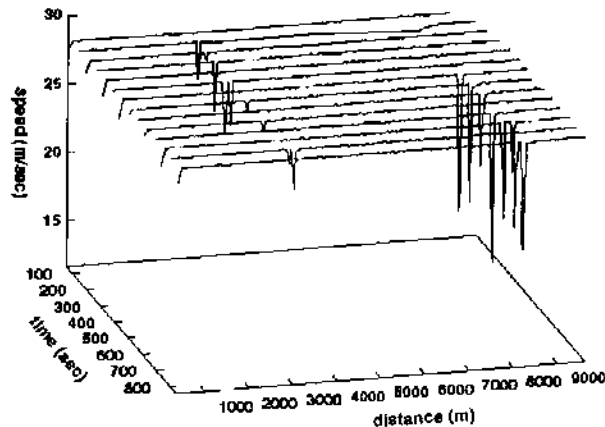

CVS A (1998)

77

Houston Case Study: Conclusions and Generalizations



- Findings indicate implementation of AHS (or longitudinal cooperation) feasible with the Houston Case Study environment, especially at low and medium demand levels
- Modest infrastructure improvements needed
- HOV/transit lane capacity could be doubled
- Communication & cooperation among automated vehicles needed to handle higher volumes
- Factors that contribute to extend applicability of Houston case study
 - Used actual data (highway geometrics, travel demand)
 - Worked with actual transportation organizations (Houston Metro Transit Authority, Texas DOT, TTI, local area consulting firm)
 - Used progressively more sophisticated and complex sequence of modeling and simulation tools
- Similar analytical techniques could be applied:
 - to other sites and scenarios
 - to other degrees of automation

CVS A (1998)

78

Summary



- We have developed methodologies and an accompanying tool set useful for any vehicle-highway automation concept
- Our methodology fuses models and tools with differing granularity and formalisms
 - producing evaluations, designs, and requirements analysis
- Our techniques are suitable for evaluating autonomous and cooperative concepts
- We have a ready-made open architecture microsimulation capability with customizable libraries of vehicle, highway, control systems, sensors, communication devices

Cooperative systems can provide higher safety and throughput, along with lower emissions and less fuel consumption

Appendix H: Evaluation Systems and Tools Status (Misener)



Tools Status vs. IVI Needs

Presented by:

Jim Misener

Prepared by:

Members of NAHSC Tools (B5) and Concept Analysis (C2 and C3) Groups at PATH

Monday, April 27, 1998: 12:45pm

SmartAHS: Microsimulation to Evaluate Vehicle-Highway Technologies



- Supports a variety of desired granularity levels
- Allows creation of specific simulations for specific scenarios
- Provides built-in libraries of ready-to-use components, including established models
 - Highway designer
 - Vehicle models
 - engine, brakes, tires, steering
 - Control algorithms library
 - vehicle automation and human drivers)
 - Sensor models
 - Including perception module)
 - Weather representation
 - VREP: vehicle-roadway environment processor
- Open architecture
 - modular
 - accommodates other users' models

CVE A (199)

81

Interrelationships Between Modules within SmartAHS

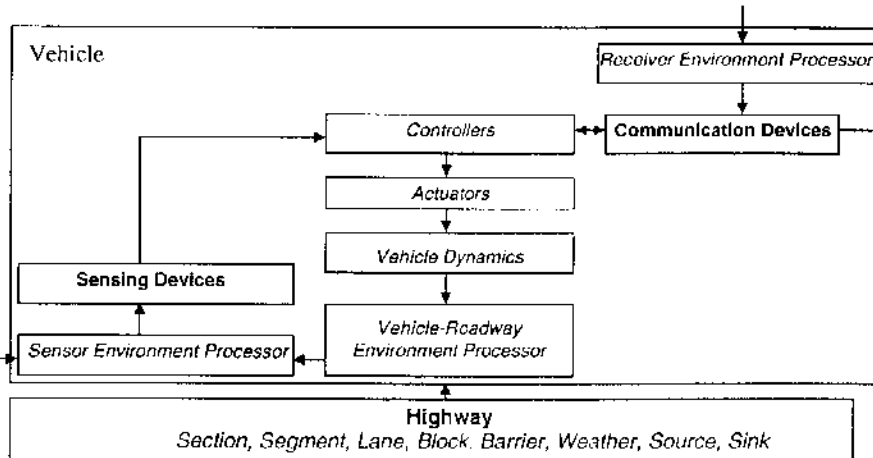

CVE A (199)

82

Potential SmartAHS Extensions for IVI



- **Enhanced heavy truck and bus models**
- **Incorporation of human driver models**
 - Extended human perception and decision making libraries
 - Human behavior in emergencies and in congestion
- **Improved sensor library and communication libraries**
 - Inclusion of additional millimeter wave and laser radar models
- **Real-time extension (to link with hardware-in-the-loop experiments)**
- **Fault diagnostics for vehicle-highway systems, including formal verification**

Appendix I



Lessons Learned from Demo '97 on Cooperative and Autonomous Systems

Steven E. Shladover
California PATH Program

Monday, April 27, 1998
1:00 PM

SES@NAHSC 4/98

1

Demo '97 Summary Cooperative and Autonomous Features



Scenario (380 miles/vehicle)	Number of Automated Vehicles	Automated Vehicle-Miles Traveled	Lateral	Longitudinal
Evolutionary (Toyota)	2	760	A	A/C
Free Agent (CMU/Houston)	5	1900	A	A/C
Control Transition (Honda)	2	760	A/C	A/C
Maintenance (Caltrans/LMC)	1	380	A	-
Platoon (PATH/GM/Delco)	8	3040	C	C
Heavy Truck (Eaton-VORAD)	1	380	-	A
Alternative Technology (OSU)	2	760	A/C	A
Total	21	7980		

SES@NAHSC 4/98

2

Control Transition Scenario



- **Unique for direct comparison of cooperative and autonomous**
- **Lateral Control:**
 - Autonomous (vision)
 - Cooperative (magnetic)
- **Longitudinal Control:**
 - Autonomous (laser rangefinder)
 - Cooperative (laser + radio communication)

Autonomous and Cooperative Lateral Sensing Systems



- **Autonomous (Vision system)**
 - Advantages
 - look-ahead information
 - requires less infrastructure support
 - Disadvantages
 - more complicated in-vehicle processing
 - noisy lateral estimates
 - larger delays, i.e. >100 msec
- **Cooperative (Magnetic system)**
 - Advantages
 - robust, high resolution lateral estimates
 - Disadvantages
 - short look-ahead distance
 - requires infrastructure modifications

Comparison of Lateral Position Measurements

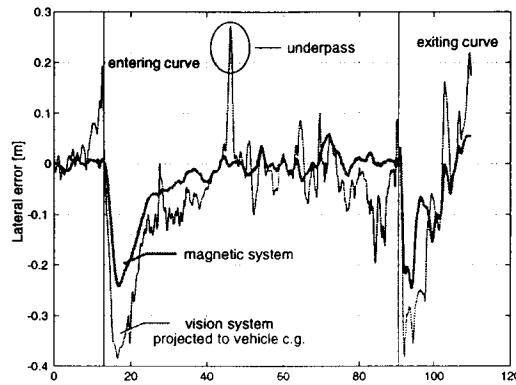

Data obtained simultaneously under magnet-based lateral control, not using curvature information. Addition of curvature information from magnets would greatly improve curve entry and exit transitions.

Comparison of measurement noise levels

$$\sigma_{\text{Vision}} = 0.92 \text{ cm}$$

$$\sigma_{\text{Magnet}} = 0.21 \text{ cm}$$

SES@NAHSC.4/98

5

Transition between Autonomous and Cooperative Lateral Control

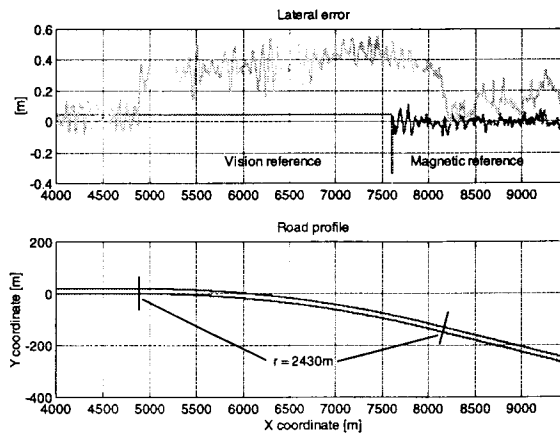

Southbound run on I-15

SES@NAHSC.4/98

6

Use of Longitudinal Sensing and Vehicle -Vehicle Communication Systems



- **Autonomous: following vehicle targets the preceding vehicle's velocity**
 - Spacing information given by laser
 - Closing rate information estimated from laser range output
- **Cooperative: lead and follow vehicles work together to ensure tight spacing**
 - Spacing information given by laser
 - Lead vehicle radios back its velocity and acceleration

SES@NAHSC.4/98

7

Longitudinal Control - Comparison of Performance

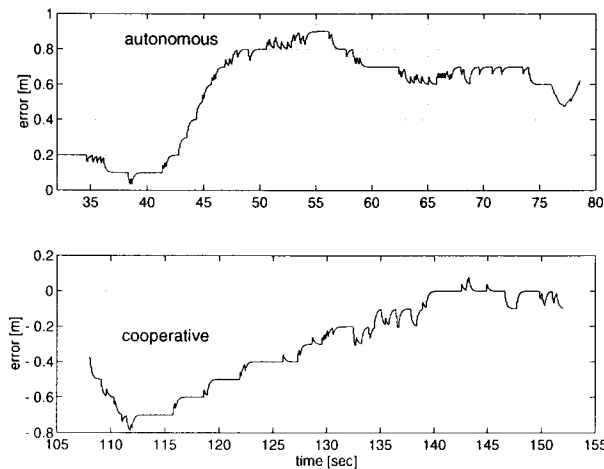

Steady state plots of spacing error.
The slow trend fluctuations are the result of road grade perturbations.

SES@NAHSC.4/98

8

Longitudinal Control Performance - Summary



- **Steady-state tracking errors are similar:**
 - $\sigma_{\text{autonomous}} = 26 \text{ cm}$
 - $\sigma_{\text{coop}} = 25 \text{ cm}$
- **Transient performance is very different**
 - autonomous has spacing errors $> 4 \text{ m}$

Platoon Scenario - Cooperative Features



- **Longitudinal Control**
 - vehicle-vehicle communication every 20 ms:
 - acceleration
 - velocity
 - position (magnet number)
 - vehicle-vehicle communication every 60 ms
 - maneuver numbers
 - condition flags
- **Lateral Control**
 - Magnetic markers in roadway, every 1.2 m

Cooperative Lateral Control for Mini-Demo

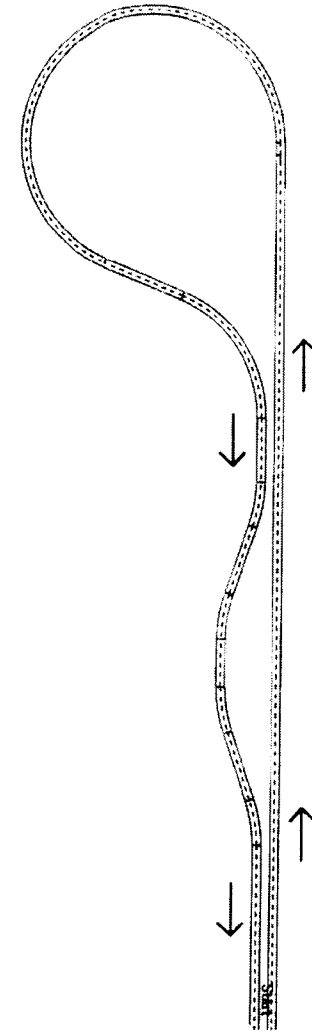
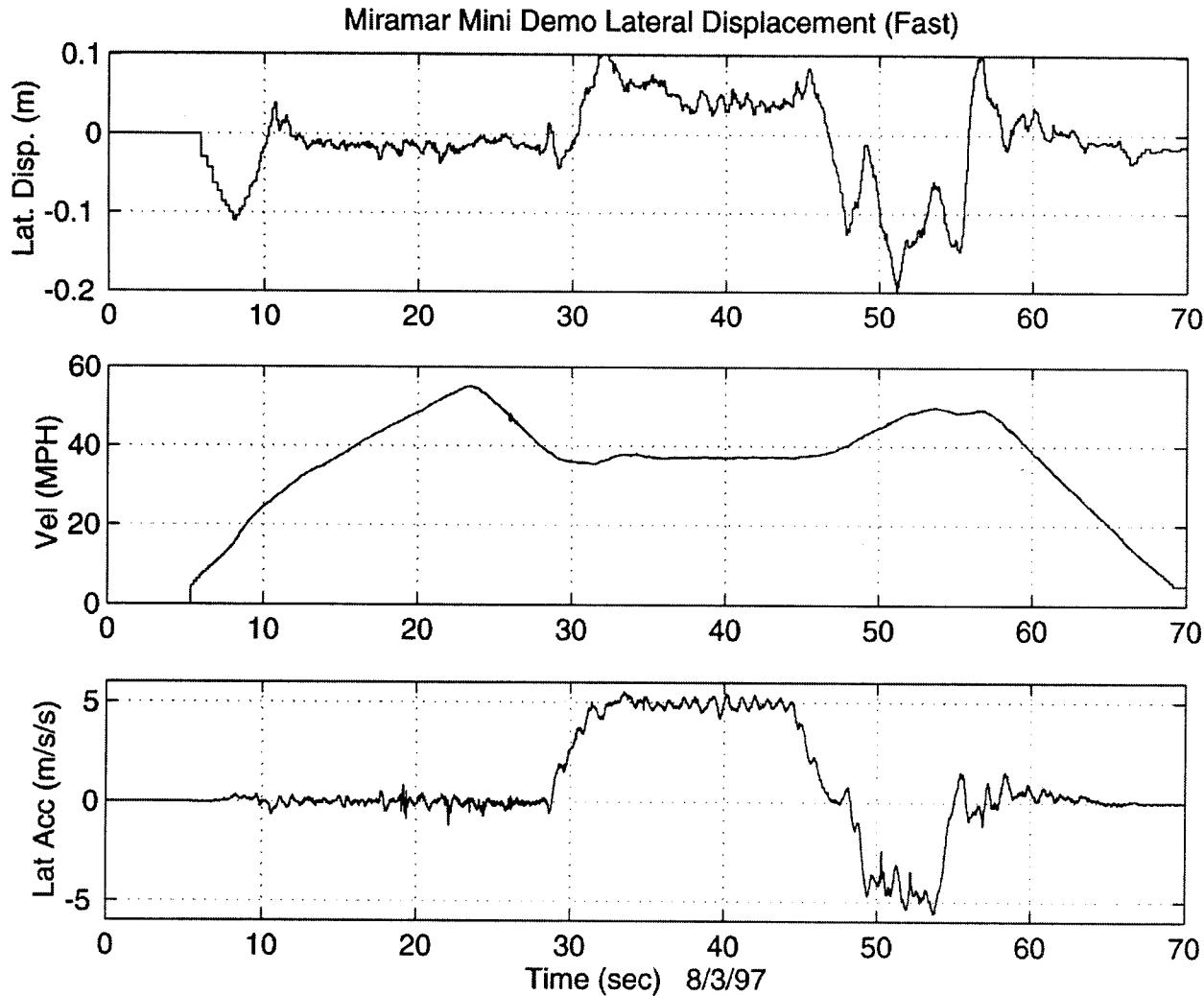

Cooperative Lateral Control Performance Compared to Highly Skilled Human Driver



I15 HOV Lane Automated vs Manual Steering Control (South Bound)

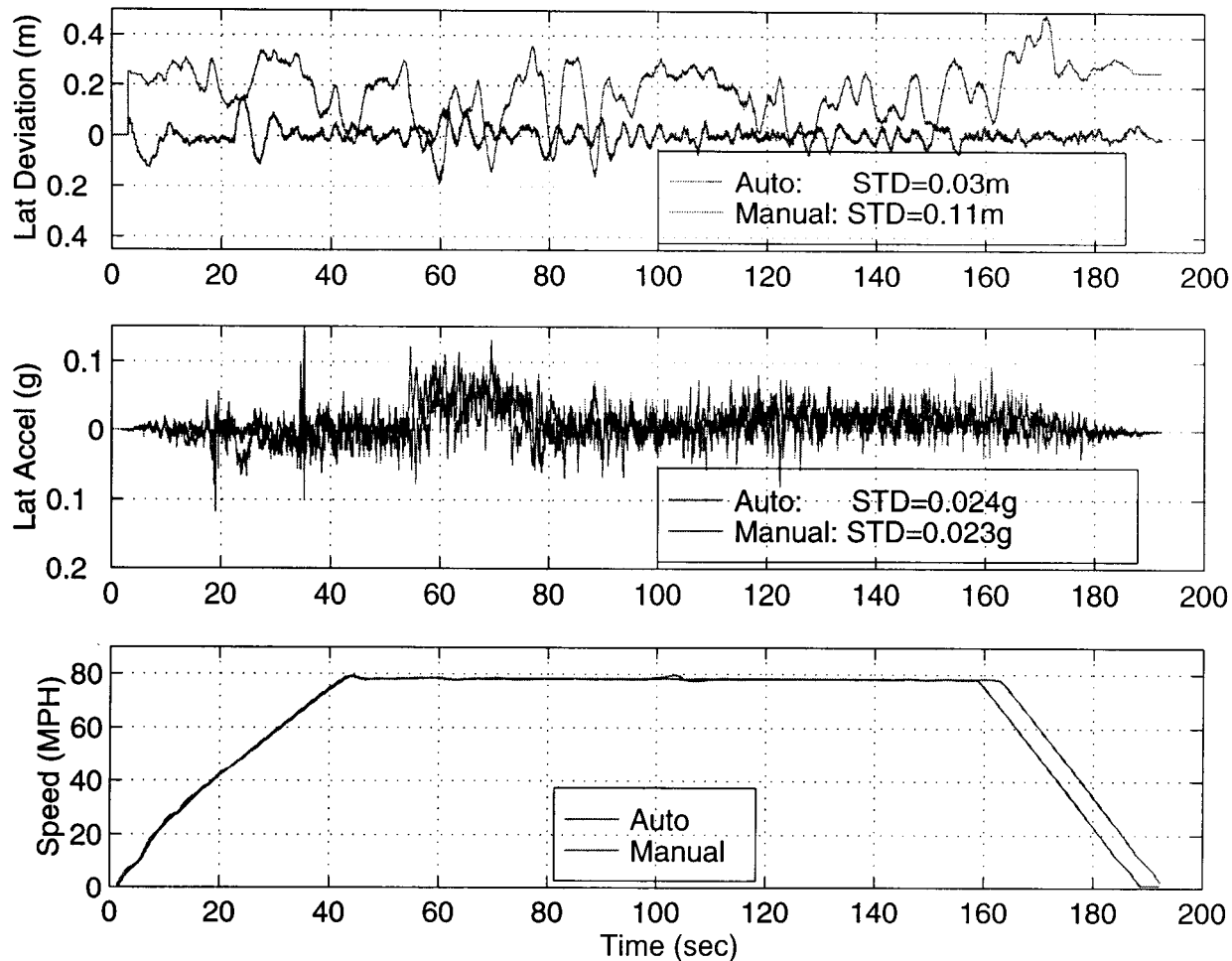

Consistency of Cooperative Lateral Control Within Platoon

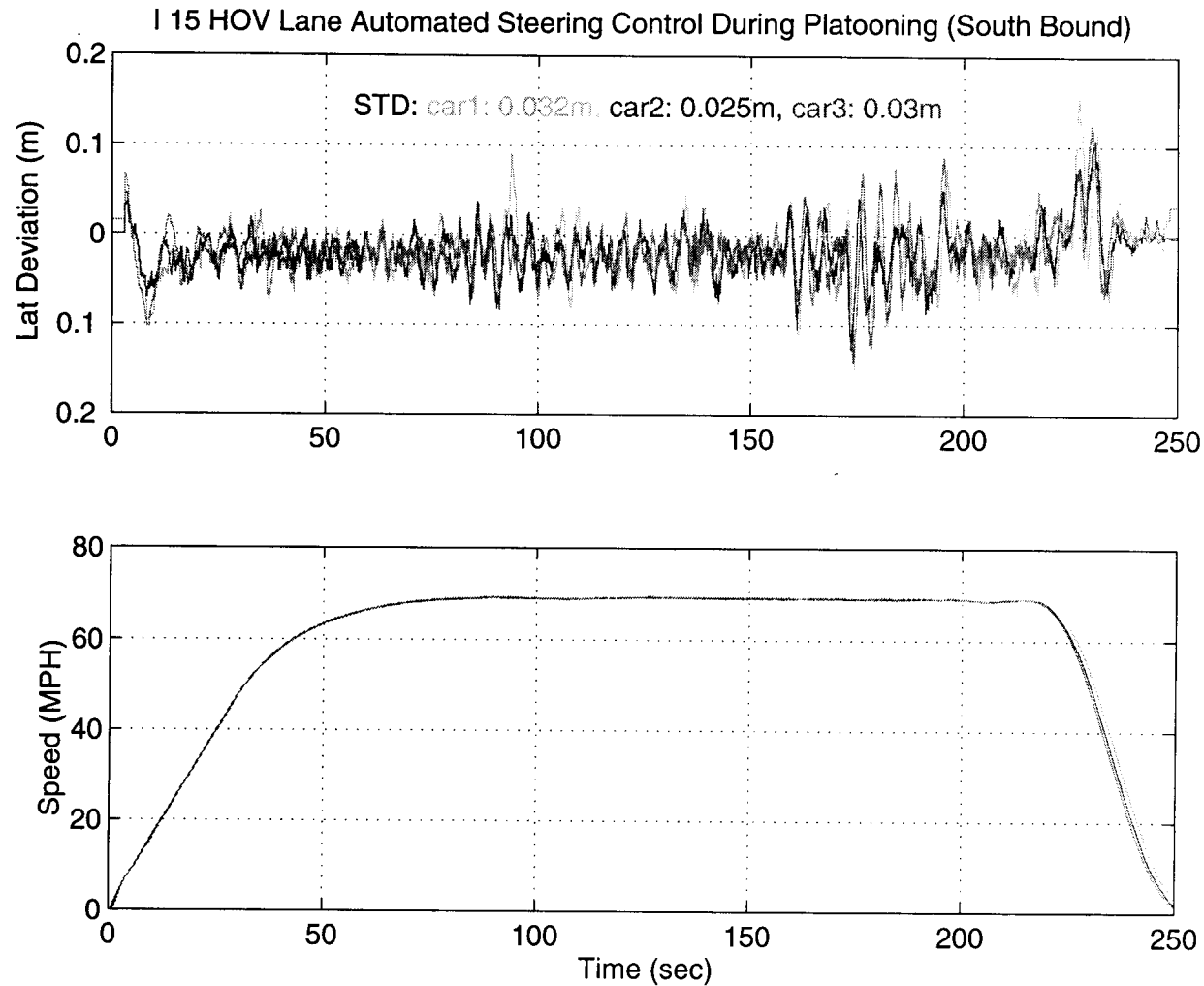

Comparison of Autonomous and Cooperative Vehicle Following Performance Without Extra Filtering of Sensor Data

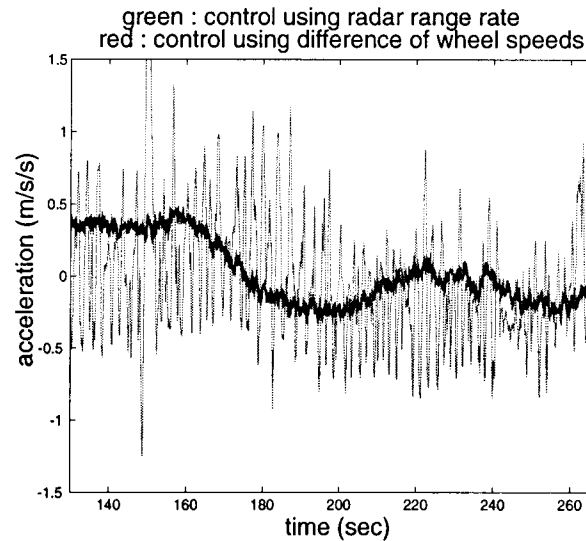
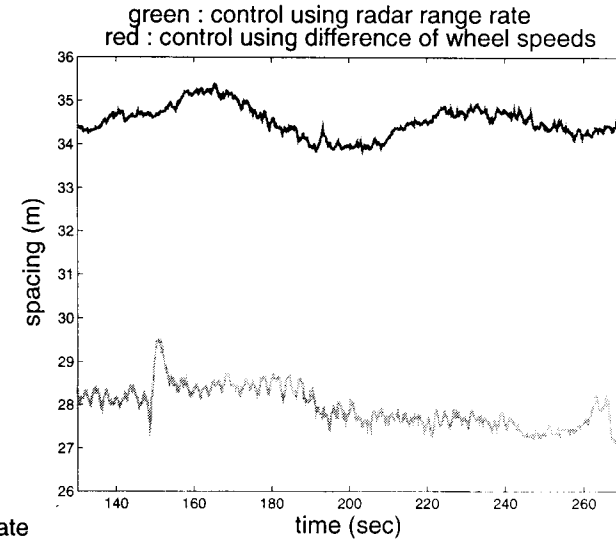
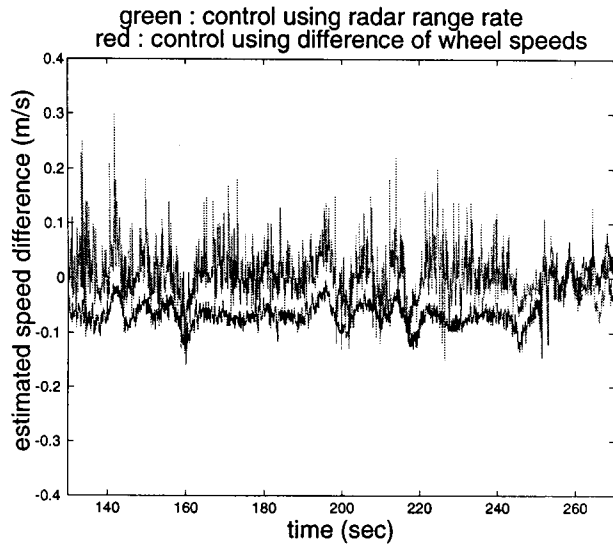

Emission Reductions

CO: 13%

HC: 9%

Comparison of Autonomous and Cooperative Vehicle Following Performance With Extra Filtering of Sensor Data

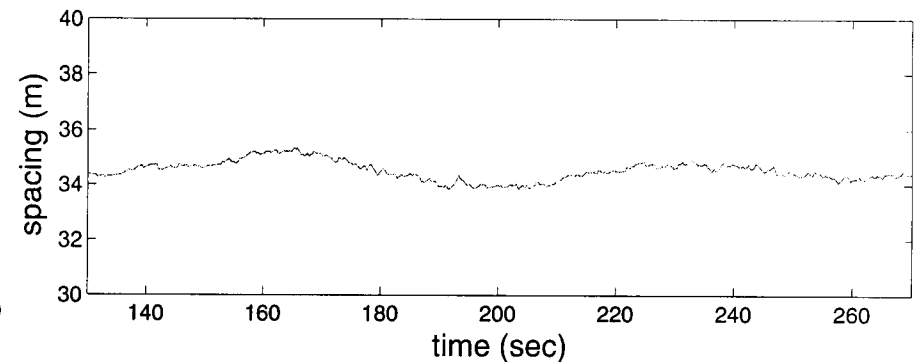
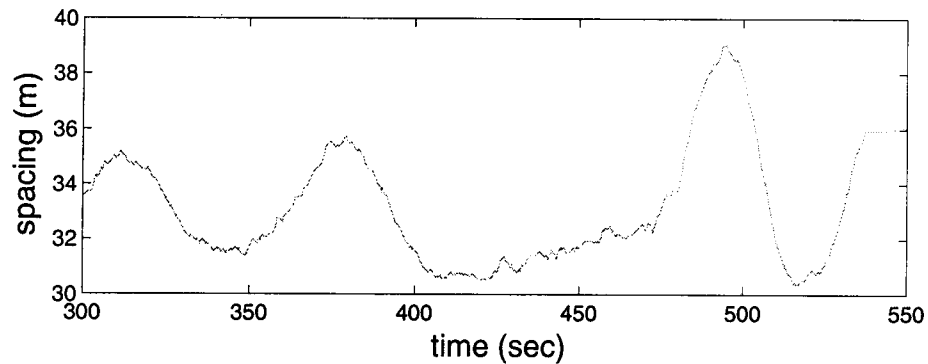
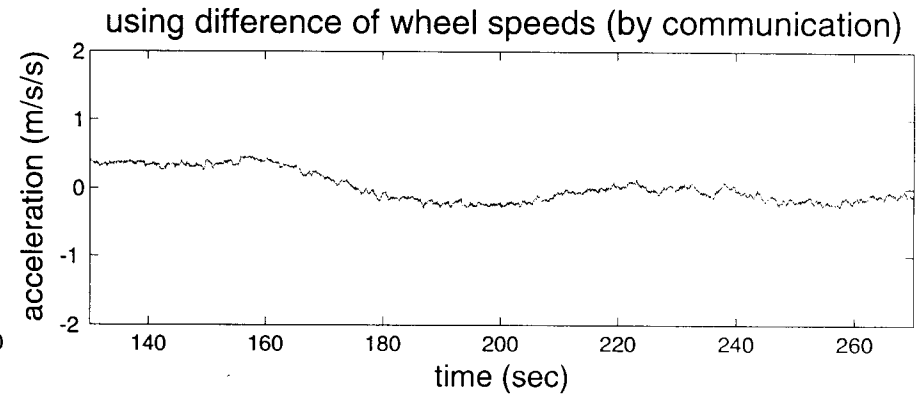
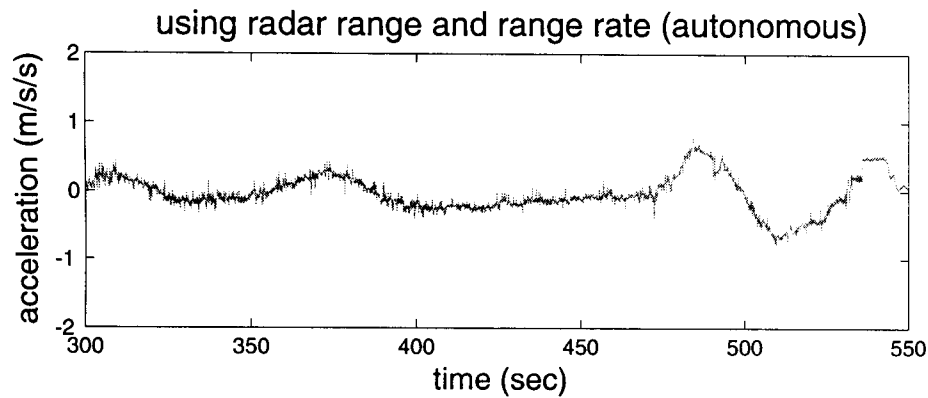

Precise Cooperative Vehicle Following

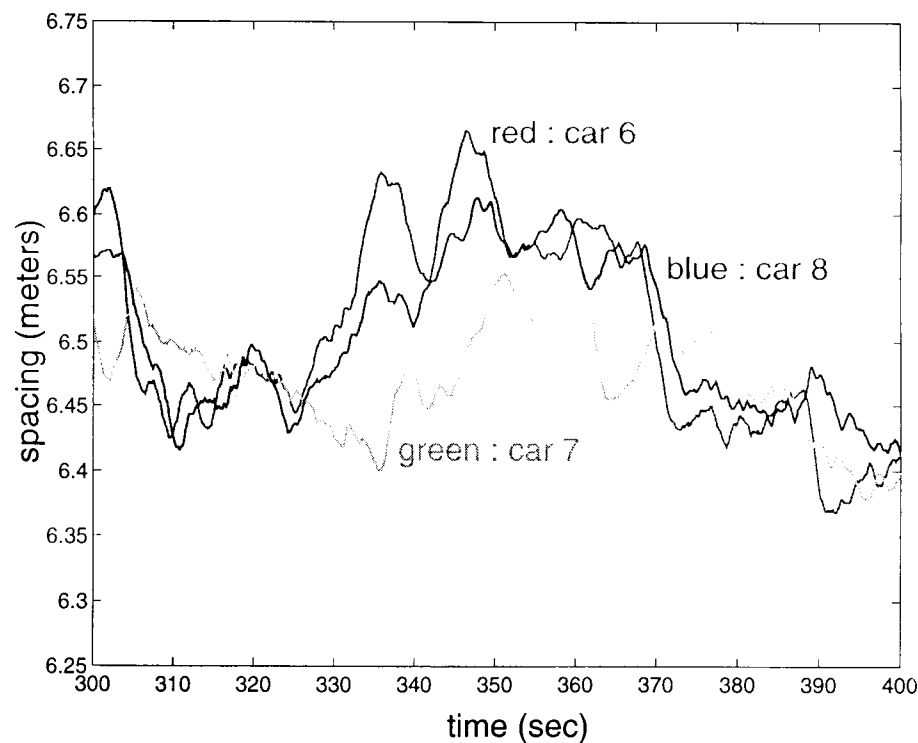
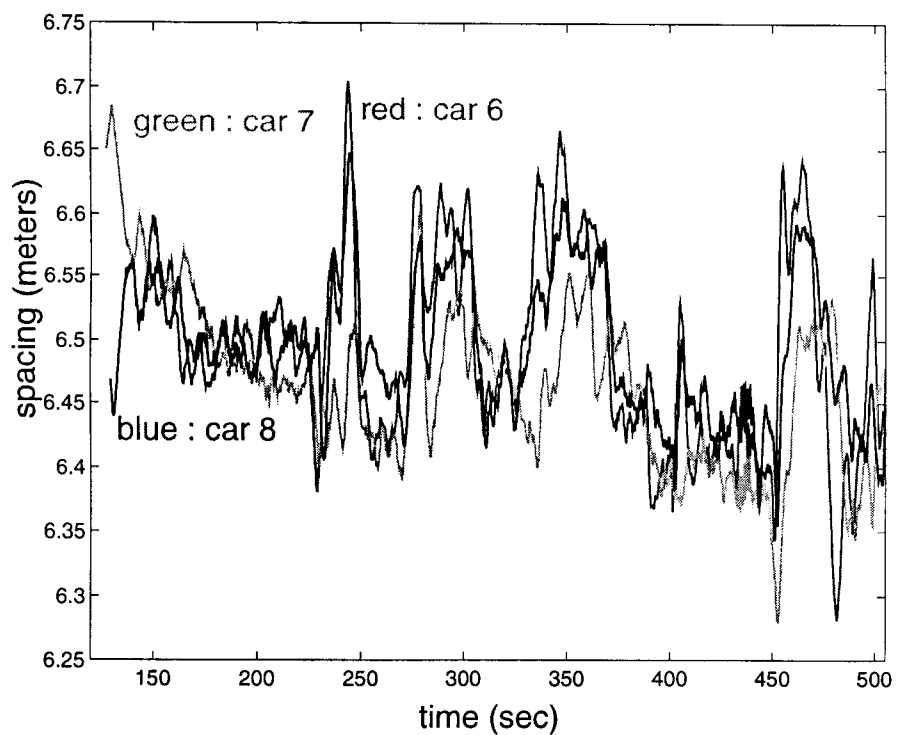

Use of Cooperative Data for Malfunction Management to Improve Robustness of Demo '97

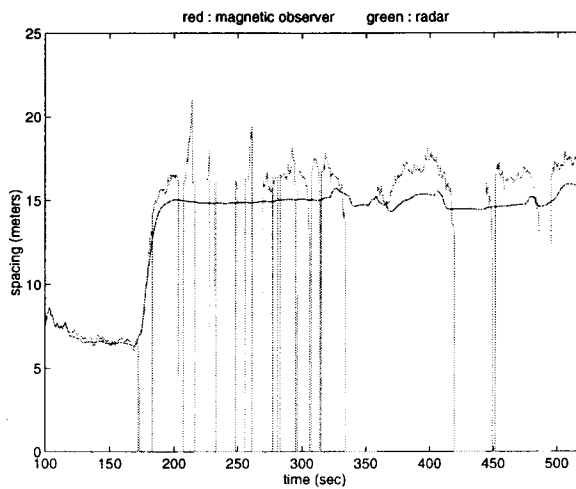

Comparison of Cooperative (Before Fault) with Autonomous (After Fault) Performance in Demo '97

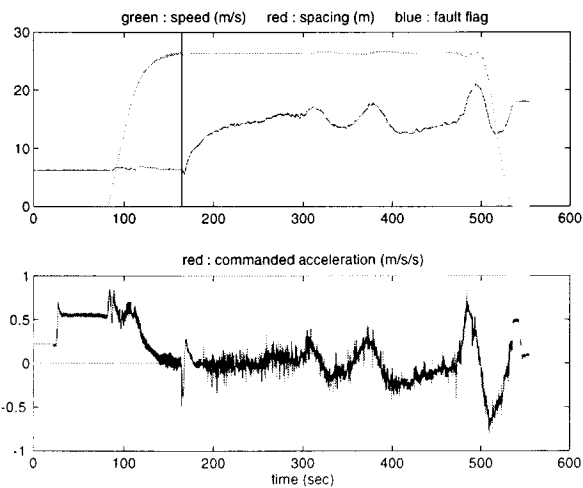

**Summary of Lessons Learned from Demo '97
on Cooperative and Autonomous**



- **Cooperative systems were shown to have:**
 - higher accuracy
 - less noise (smoother performance)
 - more opportunities for fault detection and data fusion
 - robustness to accommodate failures



NAHSC Societal and Institutional Research:

Lessons Learned for IVI

Alan Lubliner, Parsons Brinckerhoff
Monday, April 27, 1:50 pm

Societal/Institutional Research: Introduction



- *Why* institutional and societal issues research was undertaken
- *What* are the issues
- *How* the research was done

S&I Introduction (continued)



■ Significant Findings for IVI

- Public Transit
- Selected Findings:
 - Public/Private Sector Roles
 - User Needs/Market Demand
 - S&I Benefits/Costs/Tradeoffs
 - Operations/Maintenance
- Liability
- Agency Issues and Concerns

IVI Services and Areas of Concern



-
- | | |
|--|-------------------------------------|
| ■ Collision Avoidance
(RE, RD, Merge) | ■ Driver Comfort and
Convenience |
| ■ Location-specific | ■ Vehicle Stability
Assistance |
| ■ Automatic collision
notification | ■ Driver Condition |
| ■ Real Time Traffic and
Traveler Info | ■ Vehicle Diagnostics |
| | ■ Safety Event Recorder |

IVI Services and Areas of Concern (continued)



-
- Obstacle/ Pedestrian Detection
 - Precision Docking
 - Fully Automated Control
 - Longitudinal Control
 - Lateral Control
 - *System Integration*
 - *Compatible Deployment Timetables*
 - *New Areas of Research*
 - *Critical Issues*
 - *User Acceptance*
 - *Benefits, Costs*

Why Undertake S&I Research (Market, Deployment, Operations)



-
- **Deployment & Design**
 - **Elicit “Voice of the Customer”**
 - What are problems/needs as defined by customer/other stakeholders?
 - Are alternative solutions the best way to address these needs/problems?
 - **Provide Substantive Response to Stakeholder Questions/Input**
 - **Reality check, validation; is there a market?**

S&I Issues: Background



■ AHS PSA studies documented 35 issues, risks, concerns in areas of:

- legal, regulatory
- intergovernmental
- private sector participation
- environmental
- user acceptance
- societal
- funding

Issues Selection Process



■ Many of 35 PSA-identified issues:

- resolved during PSA effort
- being resolved by others (e.g. Privacy Task Force of ITS America)
- determined to be unresolvable

■ NAHSC selected 14, later narrowed to 12; achievements in 10; still working 7 at demise

■ Majority of issues relevant to IVI

NAHSC Research Agenda



-
- *AHS and Local Land Use, Economic Development Plans*
 - *Agency/MPO/State DOT Process*
 - *Public, Private Sector Roles in Construction and Operation*
 - *Institutional Considerations for Operations, Maintenance*
 - *Liability*
 - *AHS and Sustainable Development*
 - *Market Demands*
 - *the Human in the System*
 - *AHS Transit Operations*
 - *Institutional/Societal Costs, Benefits, Tradeoffs*
 - *Social Equity*
 - *Other Environmental*

Research Methodologies: Focus on Real World



-
- **Literature Review**
 - *transportation-land use*
 - *sustainability*
 - *cost/benefit/tradeoffs*
 - *agency/MPO/DOT process*
 - *liability*
 - *human factors*
 - *air quality*

 - **Commissioned studies, papers**
 - *transportation-land use*
 - *transit*
 - *operations/maintenance*
 - *human factors*
 - *sustainability*
 - *liability*
 - *air quality*

Research Methodologies (continued)



-
- **Panel discussion**
 - *transportation-land use*
 - **Meetings**
 - *TRB Freeway Ops, APTA, APTS*
 - **Focus groups**
 - *ITS America*
 - **Interviews**
 - *10 cities/regions*
 - **Workshops**
 - *liability*
 - *planning*
 - *operations/ maintenance*
 - *SANDAG, Southern California ITS Priority Corridor*
 - **Surveys**
 - *user needs/market demand*
 - *transit*

Research Methodologies (continued)



-
- **Evaluation Tools Development**
 - *user needs/market demand*
 - *transportation-land use*
 - *cost/benefit/tradeoffs*
 - *regional travel*
 - *air quality effects*
 - **Case Studies and case studies**
 - *Houston*
 - *Pittsburgh*
 - *EZ Pass*
 - *SR 291*
 - **Training Course**
 - *Agency/MPO/DOT planning process*

Significant Findings: Public Transit



■ Research Methodologies:

- Commissioned study: Transit Operating Concept, Local Applications
- Interviews: Montgomery Co., MD; Seattle; Houston; Pittsburgh
- Meetings: APTA, APTS
- Surveys: Demo '97, Houston Demo

■ Products Available:

- Transit Concept Paper, ITS World Congress
- Perspectives Issue #5
- Pittsburgh East Busway study

Public Transit (continued)



■ Increased capacity provided by AHS can provide for future growth required by Houston Metro busway/HOV system

■ Automated Transit Operations Concept developed

- Performance features of rail transit at substantially less cost
- Serving need for more flexible, customer-responsive service

Public Transit (continued)



-
- **Automation provides opportunities for transit systems with constrained ROW**
 - Pittsburgh
 - Seattle
 - New York
 - Cleveland
 - Chicago
 - **Other applications include bus maintenance facilities/operations (Chicago, Seattle)**
 - **Advanced services equipment should be capable of being retrofitted to fleet**

Transit: Pittsburgh East Busway



-
- **Three progressive levels of advanced transit services/technologies (plus one mechanical alternative)**
 - **Concept Bus 1 included precision docking in market package with other passenger benefits**
 - **Concept Bus 2 added Collision Avoidance back-up; Concept Bus 3 added automated ACC, lane keeping**

Pittsburgh East Busway (continued)



■ Limited C/B analysis

- one viewpoint (PAT); increased ridership as benefit
- 12 year planning horizon
- uncertainties produced large ranges for values
- Concept Bus 1 analyzed for whole system; others for busway only

■ Concept Bus 1 C/B positive w/in 5 years

■ Concept Bus 2, 3 “feasible”

Houston Demo



■ Development and administration of survey, building upon survey database from Demo '97, focusing on transit-specific questions

■ Contributions to the development of the announcement, agenda, background paper and breakout session questions for the FTA Workshop

Public Transit and IVI



■ IVI Services

- Transit needs/wants the same services as other vehicle classes
 - Merge/Lane Change
 - Rear End CA
 - Road Departure CA
- Modest improvements to existing busways/HOV lanes to gain increased capacity (Houston)

Public Transit and IVI (continued)



■ IVI Services (continued)

- IVI Areas of Concern include:
 - sensor warning/control
 - driver-vehicle interface
 - user acceptance
 - benefits (multiple stakeholder groups: owner/property, funding body, driver, passengers)

Public Transit and IVI (continued)



■ Autonomous/Cooperative Systems

- added capacity (technical/policy needs), overcoming ROW constraints based on cooperation
- new paradigm/automated transit operations concept benefits based on cooperation
- precision docking based on cooperation

Public Transit and IVI (continued)



■ Significant terminated NAHSC Research - IVI Needs

- User acceptance survey (transit survey designed, administered, data collected)
- Seattle/Eugene/San Diego/Montgomery County case study(ies)
- Labor issues/acceptability

Selected Findings: Public/Private Sector Roles: EZ Pass case study



Products Available:

- Report
- Perspectives Issue #2

- **Necessary Levels of Commitment**

- **Determine Market Demand**

- **Develop Business Approach/Understand Business Issues**

- **Satisfying Highest Technical Demand Raises Equity Issues**

- **Technical Lock-in Leads to Obsolescence**

Selected Findings: User Needs/Market-Demand



■ ***Products Available***

- Report
- Perspectives Issue #4

- **Initial Internet Survey**
 - **Current freeway system generally high-rated, but gets lower marks for:**
 - **driver stress**
 - **congestion**
 - **environmental impact**
 - **AHS received positive comments on potential merit and traffic safety**

User Needs/Market-Demand (continued)



■ Demo Surveys

- riders
- stakeholder categories

■ Information Accelerator

■ Autonomous and Cooperative Systems

- driver stress potentially benefitted by automated systems (may apply to autonomous and cooperative IVI)
- congestion, environmental benefits rely on cooperative systems

User Needs/Market-Demand (continued)



■ IVI Services

- Collision **Warning** Systems desirability highly-rated by Internet respondents
- In addition to addressing stress, congestion, environmental effects, major concerns about *new* services include:
 - safety/reliability
 - cost
 - driver interface

Market Analysis: Info Accelerator



“Consumers do not respond reliably to product concepts with which they have had little or no previous experience; they find it hard to envision where such a product would fit into their lives.” (Volpe Center, 1994)

The Boston Globe
June 2004
Automated Highway Systems to Be Operational in Boston by the New Year

The year 2005 will bring about a number of new changes including changes in the way in which people will commute on the Boston freeways. No longer will you have to keep on hand on the steering wheel while trying to juggle the cellular phone, your coffee mug or your eyeliner pencil.

In 1991, the United States Congress passed the Intermodal Surface Transportation Efficiency Act (ISTEA) to enhance and focus the nation's research into automated highways. Section 6054(b) of ISTEA required:

Control Technology
Sensing Technology
Information Management

The Secretary of Transportation shall develop an automated highway and vehicle prototype from which future fully automated intelligent vehicle-highway systems can be developed. The goal of this program is to have the first fully automated roadway in operation by 2005.

The AHS operates through properly equipped vehicles under full automated control on dedicated lanes. All vehicles under the AHS lanes would maintain a safe operating distance from the vehicle in front and stay in their lane of travel. With all vehicles in

[Read More Page 1](#)

Selected Findings: S&I Benefits/Costs/Tradeoffs



Products Available: Perspectives Issue #3

- Identified components of benefits and costs of interest/relevance by stakeholder group
- Established criteria for evaluation of analytical methods/tools for monetary/non-monetary and quantifiable/non-quantifiable costs and benefits
- Evaluated methods/frameworks for b/c/a
- Created analytical framework for analysis of societal, institutional, engineering costs and benefits sensitive to different system characteristics

Benefits/Costs/Tradeoffs (continued)



STAKEHOLDER BENEFIT - COST MATRICES

Stakeholder / Benefit	Society	Users	Govt Orgs	Transit	Trucks	Vehicle Manuf	Vehicle Elect Indust	Hwy Constr Indust	Enviro'l Interest	Insur'ce Indust	Included in Cost - Benefit Tool
Performance Improvement											
Time savings	✓	✓		✓	✓						✓
Reduced vehicle operating and maintenance costs	✓	✓		✓	✓						✓
Safety											
Reduced accident costs	✓	✓	✓	✓	✓					✓	✓
Improved safety for highway workers	✓	✓	✓	✓	✓					✓	✓
Improved response to incidents and emergencies	✓	✓	✓	✓	✓					✓	✓
Reliability, comfort and convenience											
Improved trip time reliability	✓	✓		✓	✓						
Reduced driver stress	✓			✓	✓						
Higher quality of service	✓	✓	✓								
Greater comfort/convenience	✓	✓		✓	✓						
Improved mobility	✓	✓									
Environmental											
Reduced noise pollution	✓	✓	✓						✓		
Reduced air pollution	✓	✓	✓						✓		✓
Fuel savings	✓	✓		✓	✓						✓
Economic and technology											
Job creation	✓					✓	✓	✓			
Spin off technology	✓		✓			✓	✓	✓			
Economic stimulus	✓		✓								

Benefits/Costs/Tradeoffs (continued)



- Costs (and benefits) most frequently cited issue with new service
- Points-of-view relevant/essential to determining factors in analysis
- 5 stakeholder groups ID'd: Users, Facility Owners (inc. Transit, CVO), Private Sector (e.g. manufacturers, builders, insurance), Non-Users (affected communities), and "Society" as a whole
- Analysis terms for transportation technology improvements identified

Selected Findings: Operations and Maintenance



Products Available:

- Consultant analysis
- SR91 paper
- Licensing/Inspection/Enforcement Surveys draft reports

■ **Operators concerned with traffic flow**

- local flexibility
- welcome new tools, with understanding of tool strengths, limitations
- geo/topographic and weather constraints common
- merging (lane change), road departure, rear end services specifically mentioned

Operations/Maintenance: SR 91 case study



■ **Lessons re:**

- Introduction of New Technology/Services and Public Acceptance
- Public-Private Partnership/Organizational Structure
- Operations/Traffic
- Social Equity

SR 91 (continued)



Public Acceptance/Benefits, Etc.

- **Language is important**
- **Measures of Effectiveness and Marketing Success**
- **Realistic Projections/Expectations Essential**
- **Benefits Must be Tangible and Highly Visible**
- **Preferably Benefits/Costs Should be Optional**
- **Benefits Can Offset Disbenefits: Tradeoffs**

SR 91 (continued)



-
- **Public Acceptance/Benefits, Etc. (continued)**
 - Importance of Public Testing to Gain Acceptance
 - Even in Orange County, private sector profit-taking evokes skepticism
 - Addressing equity: think outside narrowly-defined project definition

Licensing/Inspection/ Enforcement



-
- **Driver Licensing/Veh. Inspct'n Survey -- 8 states**
 - Arkansas, California, Maryland, Massachusetts, Nevada, New York, West Virginia, Wisconsin
 - Presented scenario as incremental deployment of equipment/services

 - **Enforcement Survey -- 16 states**
 - California, Idaho, Illinois, Indiana, Michigan, Montana, New Hampshire, Ohio, North Carolina, Pennsylvania, Oregon, Texas, Vermont, Virginia, West Virginia, Wyoming

 - **No unanimity**

Licensing/Inspection/ Enforcement (continued)



IVI Areas of Concern

- ***Driver/Vehicle Interface:*** Driver training/testing on use of special equipment, override violations/tampering/disabling

- ***Deployment Process/User Acceptance:*** Need for increased inspection, inspection criteria, training of inspectors, investigation techniques & equipment, standards, liability, collision rprts/def. of operator

Licensing/Inspection/ Enforcement (continued)



IVI Areas of Concern (continued)

- **Benefits:** Facilitates mobility for older and disabled; helps impaired drivers (and others affected by impaired drivers)
- **Human Factors:** Potential changes in driving skills, behavior, "too short headway"

Licensing/Inspection/ Enforcement (continued)



IVI Areas of Concern (continued)

- **Sensor warning & control:** Vehicle self-inspection/ testing, determining system failure; Problems experienced with electronic devices/sensors (9 of 16 enforcement respondees): *weather effects, power source problems, back up need, interference, effect of system down-time, public acceptance, testing, responsibility in case of breakdown, maintenance in general*

Licensing/Inspection/ Enforcement (continued)



Autonomous/Cooperative: IVI Areas of Concern

- Most important issues (licensing/inspection survey):
COST, reduced driver skill, liability, reliability,
inspector training, privacy

- Most important issues (enforcement survey):
SAFETY, cost/funding, drunk drivers/inattentive
drivers/training, changing mind set of officers,
licensing/inspection, congestion, legislative,
standards

Appendix K



Agency Issues & Concerns

**Deploying, owning and operating
components of an Automated Highway
System**

**Prepared by
Don Orne, Parsons Brinckerhoff**

Issues & Concerns



■ **Study methodologies:**

- Interviews
- Focus groups
- Meetings
- Special Workshops
- Training
- Case Study

■ ***Products available: draft paper, SAE
summary***

Significant Findings: State/Regional/Local Agencies: Issues Addressed



■ Primary Research Topics

- Agency/MPO/State DOT Planning and Decision-Making Process
- Public, Private Sector Roles in Construction and Operation
- Institutional Considerations for Operations, Maintenance
- Transit (where applicable)

■ Secondary Research Topics

- Land Use
- Sustainability/Environmental
- Liability/Regulatory/Organizational Structure

Agencies and Locations



- | | |
|--|--|
| ■ New York, Office of the Mayor | ■ Pittsburgh Department of Transportation |
| ■ Denver City Council, President | ■ Southwestern Pennsylvania Regional Planning Commission |
| ■ Denver Regional Council of Governments | ■ San Diego Association of Governments |
| ■ Colorado DOT | ■ Southern California ITS Priority Corridor |
| ■ Houston Metro | ■ Montgomery County (MD) Department of Transportation and Public Works |
| ■ Houston/Galveston Area Council | |
| ■ Texas DOT | |
| ■ Pittsburgh Department of City Planning | |

Agencies/Locations (continued)



-
- Minneapolis Regional Council
 - Minnesota Department of Transportation
 - FHWA, Minneapolis Region
 - University of Minnesota, ITS Program
 - King County (Seattle) Department of Transportation
 - Puget Sound Council of Governments
 - Washington Department of Transportation
 - ITS America Annual Meeting, Houston
 - TRB Freeway Operations Committee
 - APTA R&D Committee; ITS America APTS Committee
 - Caltrans Planning & Operations Staff

Agency Issues & Concerns: High Level Considerations



-
- Operations/Maintenance of Existing System of higher priority than new services
 - Federal/State/MPO roles shifting
 - Shifts in federal research interest/direction affects credibility, participation
 - State/regional/local need for data upon which to base planning/investment decisions
 - Communication is common denominator to ITS and a cooperative AHS/IVI
 - Traveler/user
 - Roadside
 - Management Center
 - Among Vehicles

Agency Issues/Concerns: 12 Themes



-
- Deployment path, incrementalism, flexibility
 - Local priorities amidst high level goals
 - Safety as primary advantage for AHS in both rural, urban areas
 - Interface with non-AHS roads, effect on local streets
 - Relationship to TSM and TMCs
 - Automation and Transit Operations
 - Special Fleets
 - commercial vehicles
 - rental car fleets

12 Themes (continued)



-
- Relationship to Planning, Economic Development
 - Liability
 - Other costs, benefits
 - Deployment Process
 - Public/Consumer Acceptance

Agency Issues & Concerns



■ Deployment path, incrementalism and flexibility

- explain logical paths
- provide for choices in direction and technologies
- show how pieces fit together

Agency Issues & Concerns (continued)



■ Local priorities among high level goals

- Convenience and comfort
- Safety

■ Safety as primary advantage for AHS in both rural and urban area

- fewer incidents/accidents can be a capacity benefit
- possible reduced accident severity

Agency Issues & Concerns (continued)



■ Safety (continued)

- fewer run-off-road accidents
- early use with snow plows and other maintenance vehicles
- dangerous weather conditions
- difficult merges and other problem locations

Agency Issues & Concerns (continued)



■ Relation to Planning and economic development

- plan with growth
- plan as part of overall transportation system
- meet local goals for managing growth
- AHS transit as means of accommodating core growth while mitigating traffic impacts
- AHS as spur for economic development

Agency Issues & Concerns (continued)



■ Liability

- Concern of DOT's that do not have much liability exposure and worry about liability shift. Fear of liability must be addressed
- safety, economic benefits
- realistic public education re benefits

Agency Issues & Concerns (continued)



■ Other costs and benefits

- design for low infrastructure cost
- narrower r/w is a cost advantage
- design for ease of maintenance
- distribution of benefits must be perceived to be fair

Agency Issues & Concerns (continued)



■ Deployment process

- get community; including business, transit, bicyclists and pedestrians, to support
- need champion
- need consensus building
- need local exposure, e.g. demo projects



Agency Issues & Concerns Follow up Interviews

**What are infrastructure
owner/operator views on
Autonomous and Cooperative
operation?**

Interview Roster



Agency	Person	DOT	MPO	Enfrcemnt	City	Transit	Rspnse
CO DOT	J. Kiljan	x					x
Houst-Galv	A. Clark		x				
WashDOT	L. Jacobson	x					x
MD DOT (fmr)	H. Kassoff	x					x
Denver COG	S. Rudy		x				x
Pittsburgh	P. Hassett				x		
MnDOT	M. Nookala	x					x
CHP	K. Baxter			x			x
MI DOT (fmr)	D. Orne	x					x
Hou. Metro.	C. Barnes					x	x
Msp MPO	N. Diaz		x				
Seattle MPO	K. Richter		x				
Caltrans	G. Larson	x					x

First Interview Question



What is your opinion of the merits of Autonomous or Cooperative systems which focus on Intelligent Vehicles?

Answers were varied and impossible to group but also rich in thought/ perceptions -- condensations of most are included here:

Viewpoints - DOT's



-
- Highways are a constructed environment with static and dynamic conditions, it is illogical to expect all vehicles to sense all static conditions or to expect the infrastructure to supply all current info.; a hybrid solution may be workable. There is great need to sense intrusion of animals.

Viewpoints - DOT's



-
- The operating base should be autonomous - cooperative is an add on benefit (may be 15-20% of total benefits)
 - The real benefits are with cooperative
 - There is a questionable role for government in IVI

Viewpoints - DOT's



-
- Vehicles “talking and listening” to the road need government support to modify the infrastructure
 - Cooperative offers technically superior systems, earlier implementation and wider range of applications
 - Cooperative systems are more complex but will be superior

Viewpoints - DOT's



-
- We need both autonomous and cooperative systems depending on specific components (e.g. braking vs. lane keeping).
 - Max. benefits will occur if both infrastructure owners/operators and vehicle developers are involved.

Viewpoints - DOT's



-
- **Reliability is a major issue for cooperative systems. There is a large array of extant devices that are unreliable -- but their use is benign. Cooperative system failure could be catastrophic.**
 - **Jurisdictional fragmentation is a daunting problem that may make cooperative systems impossible to build and operate.**

Viewpoints - DOT's



-
- **Need balance between infrastructure and vehicle systems to optimize at lowest cost - autonomous vs. cooperative is an artificial and irrelevant comparison.**

Viewpoint - Enforcement



■ Autonomous

- can be used universally
- is responsibility of owner
- no additional enforcement technology is needed when operating in mixed traffic
- no infrastructure improvements required
- public acceptance may be easier

Viewpoint - Enforcement



■ Cooperative

- allows system level operation
- greater public/private partnership synergies
- less financial burden to the vehicle owner

Viewpoint - MPO



-
- Any infrastructure dependent IVI likely to have long implementation time
 - Autonomous more likely to have incremental benefits which is critical to IVI success

Viewpoint - Transit Agency



-
- Much better traffic operations and roadway capacity with cooperative
 - With HOV's, greater safety and efficiency if adjacent bus locations are known, especially during acceleration/ deceleration

Second Interview Question - Part A



What would be the major issues to your agency that are similar to the AHS issues?

■ Cooperative

- Most included all 12 themes listed previously for AHS
- Enforcement added: CVO inspection, cost of special equipment, officer education, special enforcement in mixed traffic

Second Interview Question - Part A



■ Autonomous

- At least one person mentioned every one of the 12 themes listed previously for AHS. The unanimity was not as strong as it was for Cooperative systems
- Maintenance operations for buses was added by the transit operator

Second Interview Question - Part B



What would be the major issues to your agency that are different from the AHS issues?

Again, there were varied responses and, again, condensations will be presented here.

Second Interview Question - Part B



■ **General point made by one DOT:**

“...processes must be developed that integrate the market and institutional factors with the technology and concept development efforts so that we have a holistic approach to transportation problem solving. One that leads to deployment of useful systems...IVI is being structured like typical federal research that is unconnected to the needs and concerns of users...it will fall short of deploying useful systems”

Second Interview Question - Part B



■ Cooperative

- DOT's:
 - Cost, obligation, liability, taxation and staffing
 - How to update
 - Security, potential problem (data, communications)
- Enforcement:
 - Potential vehicle pursuit termination
 - Emergency response coordination
 - Communication failure potential
 - Driver sensory overload

Second Interview Question - Part B



Autonomous

■ DOTs

- Always operate in mixed traffic?, or, later, will it require construction of a dedicated lane?
- Is enough known about human factors to assure "driver assist" safety?
- Less concern (no need for interfacing with non-AHS, no rural/urban conflict, no TMC required, no liability shift to government)

Second Interview Question - Part B



■ Enforcement

- potential vehicle pursuit termination
- emergency response coordination
- driver sensory overload

Other NAHSC Research Topics



- **The Human in the Loop; the Psychology of Automation; Special User Group Needs**
 - *Product Available: Perspectives Issue #1*
- **Transportation/Land Use Relationship**
 - *Product Available: AHS and Land Use*
 - **AHS itself unlikely to make significant change in current land use development patterns**
 - **Possible beneficial effects on land patterns**
 - **AHS may follow demographic trends by supporting maintenance of mobility for enlarged future elderly population**

Other NAHSC Research Topics



■ AHS and Sustainability

- *Product Available: Perspectives Issue #6*
- Summarizes definitions of sustainability in a way useful to considering new transportation services
- How can new services/technologies be configured and deployed to enhance sustainability?
- Are some IVI/AHS concepts more desirable in terms of sustainability?



Appendix L: Case Studies

**Greg Larson, Acting Chief
Office of Advanced Highway Systems
New Technology & Research Program
Caltrans**

9804 Case Studies NAHSC -IVI Workshop



Case Studies

❖ Overview

- ◆ What is a Case Study?
- ◆ Why Perform Case Studies?
- ◆ Site Selection
- ◆ Methodology

❖ Examples of Case Studies:

- ◆ Western Transportation Institute
- ◆ Minnesota DOT
- ◆ Southern California ITS Priority Corridor

❖ Case Studies and IVI

❖ Conclusions

❖ Summary & Recommendations

9804 Case Studies NAHSC -IVI Workshop

What is a Case Study?



- ❖ An evaluation of the technical, economic, and institutional impacts of automation on the regional transportation system
 - ◆ Safety
 - ◆ Efficiency/Mobility
 - ◆ Air Quality/Environmental
- ❖ “Realistic” studies of local AHS deployment used to explore the potential and implications of deploying AHSs under site specific conditions
- ❖ Part of the design and development process

9804 Case Studies NAHSC -IVI Workshop

Why Perform Case Studies? NAHSC Mission



- ❖ Specify, develop and demonstrate a prototype Automated Highway System(s). The specifications will provide for evolutionary deployment that can be tailored to meet regional and local transportation needs.
- ❖ Incorporate public and private stakeholder views to ensure that the AHS is economically, technically and socially viable.



9804 Case Studies NAHSC -IVI Workshop

Site Selection



- ❖ Developed and Sent Out an RFI
- ❖ Received & Evaluated Responses
- ❖ Selected Five Locations
 - ◆ Southern California
 - ◆ Gary-Chicago-Milwaukee
 - ◆ Minnesota DOT
 - ◆ Virginia Tech & Virginia DOT
 - ◆ Michigan DOT
- ❖ Other Interested Sites
 - ◆ I-95 Coalition; Arizona; Tampa, FL

9804 Case Studies NAHSC -> IVI Workshop

Methodology

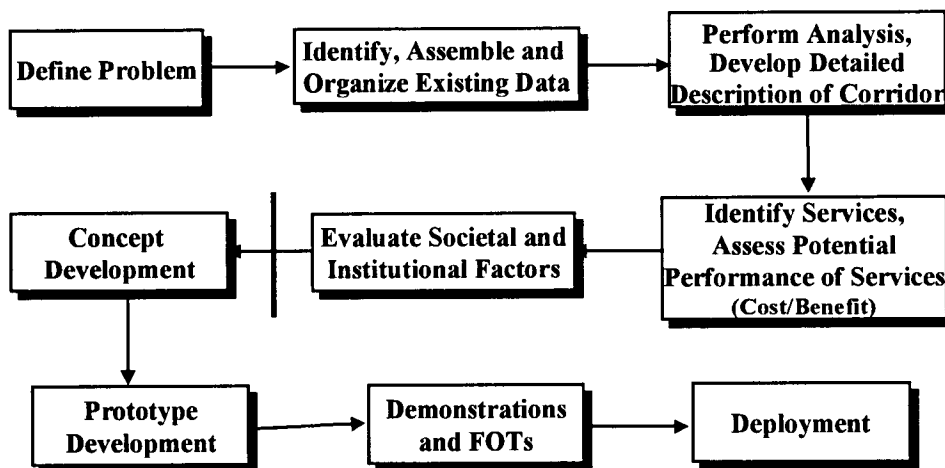

9804 Case Studies NAHSC -> IVI Workshop

Yellowstone Rural Priority ITS Corridor Western Transportation Institute (WTI)



- ❖ The focus of the case study is on enhancing the safety of rural two lane highways
- ❖ Preliminary investigation indicates that 82% of the corridor's crashes can be mitigated by automation
- ❖ AHS countermeasure concepts will be developed and phased-in through the following incremental approach:
 - a) Develop corridor concepts;
 - b) Segment testing and demonstration;

Near-term solutions - driver aids (infrastructure based);
Short-term solutions - warning systems (integrating infrastructure and/or smart vehicles - Cooperative Sys.);
Intermediate-term solutions - mixing automated and manual control (Cooperative with smarter vehicles); &
Long-term solutions - full automation

9804 Case Studies NAHSC ->IVI Workshop

WTI - Crash Trends

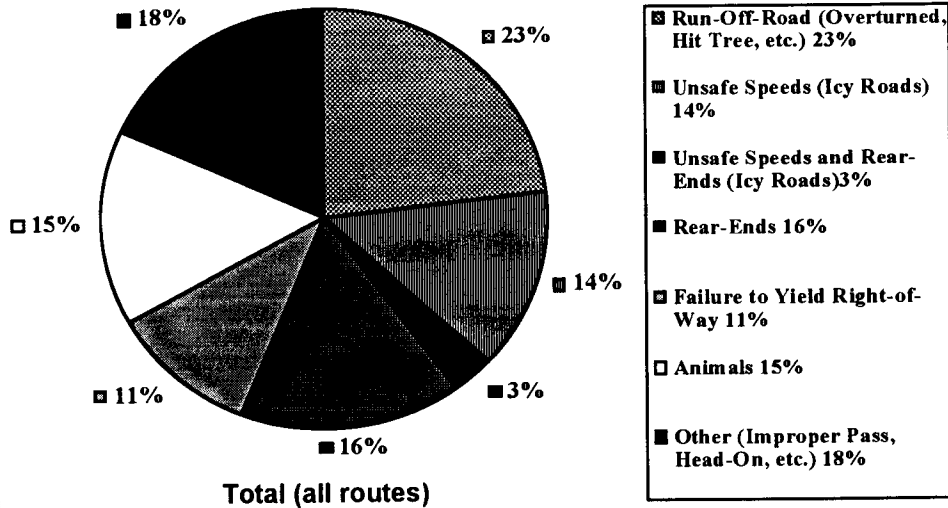

9804 Case Studies NAHSC ->IVI Workshop

Countermeasure & Deployment Development



Ice Detection (Reduced Traction)

- Time ↓
- ♦ **Near Term - Dynamic Roadside Speed Advisory**
 - ♦ Roadway Embedded Ice Detector
 - ♦ Speed Sensors & Roadside Processor for Speed Calculation
 - ♦ Dynamic Advisory Speed Sign
 - ♦ **Short Term - Cooperative Dynamic In-Vehicle Speed Advisory**
 - ♦ Roadside Communication Transmitter
 - ♦ In-Vehicle Dynamic Speed Advisor
 - ♦ **Intermediate Term - Cooperative Automated Braking**
 - ♦ In-Vehicle Brake Actuators
 - ♦ Automated Deceleration
 - ♦ **Long Term - Full Automation**

9804 Case Studies NAHSC ->IVI Workshop

Countermeasure & Deployment Development (Continued)



❖ Automated Snowplows

- ♦ **Near Term - Cooperative Lane Departure Warning**
 - ♦ Infrastructure - DGPS/Embedded Magnets/Magnetic Tape
 - ♦ In-Vehicle Sensors and Processor
 - ♦ In-Vehicle Warning System
- ♦ **Short Term - Cooperative Lane Keeping & Partial Longitudinal Control**
 - ♦ In-Vehicle Steering Actuator
 - ♦ In-Vehicle Brake Actuator
- ♦ **Intermediate Term - Full Automation**

9804 Case Studies NAHSC ->IVI Workshop

Potential Countermeasures



- ❖ Night vision enhancement
- ❖ Driver impairment monitoring
- ❖ Roadway Ice Detection
- ❖ Lateral lane-edge detection
- ❖ Dynamic horizontal curve advisory and control
- ❖ Detection of obstacles in the roadway
- ❖ Headway control
- ❖ Presence of oncoming vehicles detection
- ❖ Lane keeping

9804 Case Studies NAHSC -IVI Workshop

Minnesota DOT



System Maintenance and Operations

Automated Snow Plows

- ❖ Operational Test in 18 Months
- ❖ Lateral Control
- ❖ Front/Side Warning or Partial Control
- ❖ Spin-On to Other Maintenance Operations
 - ◆ Then CVO - Transit - Passenger Vehicles

9804 Case Studies NAHSC -IVI Workshop

Southern California



**Looking at Persistent System Challenges -
Congestion & Environment, as well as Safety**

**Considering the use of vehicle automation where
conventional solutions have proven inadequate**

- ♦ **Scope & Partnership Development - Phase I**
- ♦ **Analysis - Phase II**
- ♦ **Concept Development - Phase III**
- ♦ **Prototype Development & Testing - Phase IV**

9804 Case Studies NAHSC ->IVI Workshop

Case Studies and IVI



❖ Similar Objectives

- ♦ **Focus on near-term solutions**
- ♦ **Deployment**
- ♦ **Vehicle platforms**
- ♦ **Cross-cutting issues**
- ♦ **System integration**
- ♦ **Prototypes, demos and FOTs**

❖ Plus

- ♦ **Market, societal & institutional issues**
- ♦ **Buy-in, partnering & outreach**
- ♦ **Consideration of long-term needs**
- ♦ **Other - funding, standards, intermodal, interoperability,**

9804 Case Studies NAHSC ->IVI Workshop

Conclusions



Case Studies:

- ♦ Created an opportunity for the NAHSC to educate transportation decision makers in a region about AHS, to develop partnerships with them, and to gain buy-in from them
- ♦ Enabled the NAHSC to integrate results from the societal and institutional issues analyses, the tool development task, and the concept development task in a real world setting
- ♦ Forced the NAHSC to focus on solving specific regional transportation challenges and to look at the incremental steps that would be needed to deploy AHS in a region

9904 Case Studies NAHSC ->IVI Workshop

Summary & Recommendations



- ❖ Case studies are a powerful tool for evaluating the effectiveness of IVI services in a real world setting, and should be an important part of the IVI work
- ❖ Regions that sponsored NAHSC case studies are ITS innovators and should be considered as potential IVI case study sites
- ❖ Case Study methodology developed by the NAHSC has strong potential and should be considered for use in the IVI Program
- ❖ Under IVI, case studies could be tailored to target a specific vehicle platform, as the NAHSC did in Houston (transit) and Minnesota (special vehicle)
- ❖ Ensure that the case studies receive the resources necessary for their success

9904 Case Studies NAHSC ->IVI Workshop

Appendix M

Liability Issues with AHS

J P Blanchard, Bechtel Corp.

Information presented here is not legal advice.

Outline of Presentation

- Background: NHTSA & other projects
- Work conducted for AHS project
- Lessons learned about liability
- Critical distinctions related to liability
- Major contributions from AHS effort

Background

- In place or on-going NHTSA efforts
 - Minimum performance standards
 - Investigation of defects (vehicle recalls)
- Critical lessons from present day activities & relevance to AHS issues
 - Signage at DFW
 - Airbag Cutoff Switches
 - Recent change in General Aviation Law

Major Work Tasks

- North Carolina Central University
School of Law
 - Review examined issues across the US
 - Detailed final report to program office 1/97
 - HBCU w/ significant cost share
- National Workshop: Feb. 5-6, 1997
 - Sponsors: NAHSC/ITS America/AASHTO
 - Assistance from NHTSA, GM, SoCal AAA
 - Introduction of Nominal Group Technique

Workshop Participation

■ Manufacturers
■ Insurance & other legal
■ DOTs
■ NAHSC

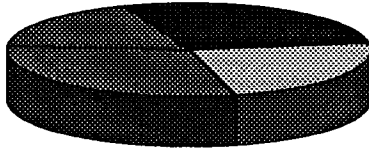

- Initial deliberations based on professional affiliations
- Further efforts conducted in mixed groups to encourage better understanding of different points of view

Workshop Conclusions

- Significant safety & economic benefits possible with automated systems
- Competition seen as biggest present barrier (except by manufacturers)
- Fear of liability is serious issue that will influence design and deployment of systems
- If automation enhances both intended and actual safety, then real liability issues may be expected to decline

Why is Liability an Issue?

- Relates to Marketability
- Legal Responsibilities
associated with Control of Actions
- Design Issues

Product Liability Exposure

Interagency Task Force on Product Liability (5/76); Stiglich thesis

- **Manufacturing Practices**
 - Defects in manufacture
 - Design
- **Tort-Litigation**
 - failure to investigate science to uncover probable harm, inadequate test & inspection
 - failure to warn user in safe use of product
 - defective construction of materials
 - failure to comply with codes or requirements
 - failure to perform as advertised
 - improper design
 - failure involving 2 or more mfgs in production
- **Insurance Rate Making Procedures**

The Reality of Liability

- Structure of Legal System
- Questions of Expectations
- Recovery of Damages
- Harm or Injury precedes
Legal Action

Critical Distinctions

- ¶ Federalism vs. States' Rights
 - system, damages, expectations
- ¶ Theories of Law
 - system, damages, expectations
- ¶ Autonomous vs. Cooperative
 - system, damages, expectations

Federalism vs. States Rights

- Who sets public policy?
- Historical basis
- Significance
- Implications

System

Different Theories of Law

- Torts vs. contracts
- Significance of difference
- Implications for NAHSC and IVI

Damages

Cooperative vs. Autonomous

- Present day analogies
- Liability implications
- Design significance

Expectations

Major contributions from AHS

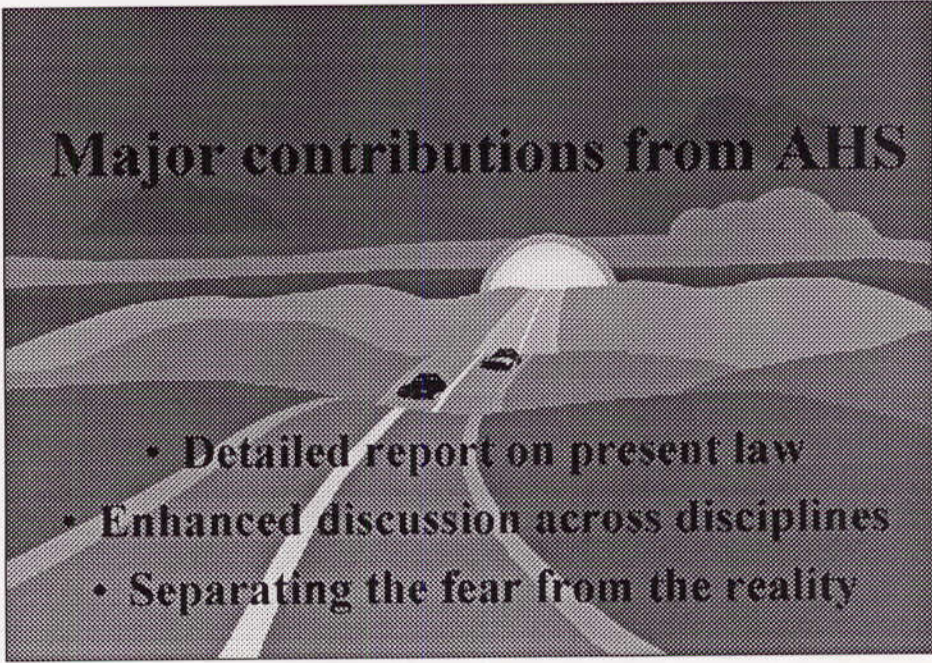
- 
- Detailed report on present law
 - Enhanced discussion across disciplines
 - Separating the fear from the reality



Appendix N

Understanding and Involving the Stakeholders

Lessons Learned from NAHSC's Stakeholder Relations Program

Roger Boothe, PB Farradyne Inc.

Tuesday, April 28, 8:00 am

NAHSC Stakeholder Relations Program: Purpose and Activities



• **Mission**

- To develop consensus among stakeholders regarding technical and policy issues

• **Objectives**

- Involve stakeholders in the on-going work of the Consortium
- Provide outreach to potential stakeholders, the public, elected officials and the media
- Encourage evolution of overall program in response to stakeholder input
- Support Demo '97

Purpose and Activities



- **Major Stakeholder Relations activities**
 - **Stakeholder Categories/Representatives**
 - **Periodic meeting to address technical and policy issues**
 - **Peer-to-peer marketing**
 - **Stakeholder Forums**

Purpose and Activities



- **Industry Presence**
 - **ITS World Congress**
 - **ITS America Annual Meeting**
 - **ITS America Committee Meetings**
 - **TRB Freeway Operations Committee**
- **Print and Presentation Materials**

Purpose and Activities



- **Demo '97 Support**
 - **VIP Outreach**
 - **Media Relations**
 - **Public Relations**
 - **Website**
 - **Brochures and Information Kit**
 - **Video**
- **Legislative Liaison**

Lessons Learned: Organizational and Procedural



- **Stakeholders are more effectively organized by area of interest than by organization type.**
- **Stakeholder Category Representation was effective but not true to its original mission.**
 - **Valuable input and active participation from elected stakeholder representatives**
 - **Not truly representative of the views of the full stakeholder categories**

*Lessons Learned: Organizational and
Procedural*



- **Stakeholders tend to feel disconnected unless you convince them that they aren't.**
- **The most effective outreach is peer-to-peer outreach.**
 - State DOT/MPO Marketing
 - Demo VIP Marketing
- **Principle of Optimality: 20% of stakeholders comprise 80% of participation**

*Lessons Learned: Organizational and
Procedural*



- **Lack of funds/staff constrains stakeholder participation.**
 - Unable to attend forums/events
 - Being a stakeholder is an “overhead” activity

Lessons Learned: Organizational and Procedural



- **Stakeholder Relations requires a specialized toolbox.**
 - At its heart, a marketing function
 - Should be led by a professional familiar with appropriate strategies, tactics, tools
 - Significant benefits from consultants
 - Strat@comm

Lessons Learned: Substantive



- **Institutional issues can make or break a transportation program.**
 - The best vision will not become a reality unless it is practical, implementable, and makes life easier rather than harder.
 - Example: AHS “5 Who’s”

Lessons Learned: Substantive



- **Linkages between AHS or a similar system and the National ITS Architecture are important and essential.**
 - Promotes interoperability
 - Levels playing field for all stakeholders
 - Establishes common ground through:
 - Market Packages
 - User Services

Lessons Learned: Substantive



- **The multi-platform, free agent AHS scenario was a preferred scenario among stakeholder representatives.**

↑ the X

(Chen Survey)
- **Among general ridership, all scenarios were perceived favorably**

(Yim Survey)

Lessons Learned: Substantive



- **Most popular AHS features were:**
 - Adaptive Cruise Control
 - Obstacle Warning/Avoidance
 - Lane-keeping
(Chen Survey)
- **Riders said most important benefits TO THEM were:**
 - reduced stress
 - make driving easier

Lessons Learned: Substantive



However...

... Most important benefits to society in general were

- increased safety
 - increased throughput
(Yim Survey)
- **A realistic deployment path for AHS or similar system includes free agent vehicles operating on dedicated lanes.**

Lessons Learned: Substantive



- **Key barriers to implementation of AHS or similar system are:**
 - **Public acceptance**
 - **Cost**
 - **Liability**
(Strat@comm survey)
- **Stakeholders believe AHS or a similar system can be most helpful in improving safety and enhancing mobility.**
(Strat@comm survey)

Implications for IVI



- **Stakeholder Organization Options**
 - **Consider alternatives to the obvious or easy structure**
 - **Let stakeholders self-organize**
 - **Organize on (a) activity-by-activity basis**
 - **Have no formal organization**

Implications for IVI



- **Understand that individual stakeholders will tend to offer a singular rather than a collective view.**
 - **May preclude a representative structure**
- **Make stakeholders feel connected through:**
 - **Constant flow of involvement opportunities, even if activities are insignificant**

Implications for IVI



- **Clearly highlighted areas where stakeholder input has impacted decisions**
- **Lots of “stuff” sent out**
 - **Newsletters**
 - **Reports for review/comment**
- **Utilize stakeholder allies to reach out to their peers**

Implications for IVI



- **Understand and accept optimatality** ?
 - Focus on energizing the 20% stakeholder core
 - Accept that most stakeholders really want to be informed, not involved
 - Understand individual/organizational motivations
- **Make it “cheap and easy” to be a stakeholder**

19

Implications for IVI



- Take forums, activities to the stakeholders
 - Conduct on regional or statewide basis, use facilities/resources of DOTs and private sector allies
- Accept minimal time commitments
- **Employ skilled professionals to plan and lead your stakeholder program**
 - A marketer, not a technical professional, should head

Implications for IVI



- Use consultants
- Let the Outreach professionals do their jobs, and listen to their counsel. They know more about Outreach than you do.
- **Assess and address institutional and policy issues up front**
 - Plan from the standpoint of those who must implement

Implications for IVI



- **Focus on linkages between IVI and the National ITS Architecture**
- **Consider stakeholder views regarding AHS deployment scenarios in crafting IVI**
- **Recognize that there may be a disconnect between desired/perceived benefits to the individual stakeholder and desired/perceived benefits to society**

Appendix O
Societal & Institutional



Conclusions & Recommendations for Future Research

April 27, 1998 3:00 PM
April 28, 1998 8:30 AM

Conclusions: Understanding Societal/Institutional Issues



-
- **Engineers and research scientists from other disciplines often do not understand or appreciate either the nature of societal research or its importance.**
 - **Those involved in the implementation of transportation improvements come face-to-face with these issues -- frequently too late to respond adequately or effectively.**

Conclusions: Understanding Societal/Institutional Issues



- It is necessary to integrate societal, institutional and environmental research and findings into the development and design of transportation services and/or improvements from the outset.

Conclusions: Understanding Societal/Institutional Issues



- A successful front end process may appear inefficient -- but there is no apparent better way to attain focused understanding, responsiveness and support from those having a stake in the improvement. This is essential for implementation.

S&I Conclusions: Purpose and Need



- Address problems of current highway system: driver stress, congestion, environmental impact.
- Address major concerns about new services: cost, safety/reliability, driver interface.

S&I Conclusions: IVI Services



- Most effective, desired services common to all vehicle platforms
 - Transit and commercial vehicles may offer better opportunities (than light duty vehicles) for early introduction of such services.

S&I Conclusions: IVI Services



- **Specific services cited as desirable and needed include:**
 - Collision Warning and Avoidance (ACC, obstacles, rear-end)
 - Lane keeping
 - Merging
 - “Precision Docking” (transit)

S&I Conclusions: Analysis



- **Benefit and cost analyses should be undertaken from the multiple viewpoints of different stakeholders; tradeoffs explicit in policy decisions (address social equity issues as part of tradeoff analyses).**
- **Benefits must be tangible and highly visible**

S&I Conclusions: Market/Testing



- **Determine market demand/Develop business approach/Understand business issues. Consider need/impact of standards.**
- **Perform public testing, in multiple locations**
 - Determine Measures of Effectiveness
 - Provide realistic projections, expectations
 - Disseminate results immediately

S&I Conclusions: Market



- **Autonomous and cooperative systems, and especially automation, can extend mobility for, and thus complement, the demographics of our aging population.**

S&I Conclusions: Case Studies



■ Case studies:

- Created opportunity to educate transportation decision-makers in a region about AHS, to develop partnerships with them and to gain buy-in
- Enabled the integration of some results from the S&I issues analysis, simulation tool development, and concept development in real world setting

S&I Conclusions: Case Studies



■ Case Studies (continued):

- Forced the NAHSC to focus on solving specific regional transportation problems, and to look at the incremental steps that would be needed to deploy AHS in a region

S&I Conclusions: Agency Issues



- Operations and maintenance of existing system is highest priority for DOT's/MPO's/cities: how do new services further that priority?

S&I Conclusions: Agency Issues



- Need to address the total surface transportation system in an integrated way
 - System assessment, terminals and interfaces
 - Policy
 - Intermodal

S&I Conclusions: Agency Issues



- **Keep service architecture open**
 - Provide options
 - Allow local flexibility
 - Technical lock-in leads to obsolescence

S&I Conclusions Agency Issues



- **There is a long lead time and new services (e.g. AHS/IVI) must fit into the “standards of practice” of the transportation industry e.g. documents, manuals, processes, procedures, community involvement etc.**
- **Proposed services must “fit” in plans/funding programs.**

S&I Conclusions Agency Issues



- **States/Regions need information NOW:**
 - To deploy autonomous services for government fleets (light duty, transit, trucks)
 - To deploy infrastructure-cooperative services beyond generation 1 in 5 years

S&I Conclusions: Agency Issues



- **Equipment required for autonomous or cooperative systems must be capable of being retrofitted to transit .**
- **Autonomous and cooperative systems, if offered as part of market packages that include other ITS passenger services, can meet cost/benefit test for transit.**

S&I Conclusions: Agency Issues



- Automated transit operations can be designed, consistent with current thinking in transit service, to serve the need for more flexible, customer-responsive service.
- Automation is a way to provide increased capacity to meet future demand on HOVs and busways, without impeding bus operations.

S&I Conclusions: Agency Issues



- Automation provides opportunities for transit systems with constrained rights-of-way -- a problem in cities throughout the country.

S&I Conclusions: Involving Stakeholders



- **Stakeholder program taught us both organizational/procedural and substantive lessons learned that can be applied to IVI**
- **Organizational/Procedural Lessons:**
 - Tailor organization to participants, not vice versa
 - Make it easy for stakeholders to participate
 - Expect minimal participation from all except core group

S&I Conclusions: Involving Stakeholders



- **Substantive Lessons**
 - Linkages are important (Nat'l Architecture, ITI, MDI, etc.)
 - Cooperative vehicle/highway systems are preferred
 - The public is ready for something new
 - IVI will likely face similar barriers
 - Acceptance
 - Liability
 - Cost

S&I Conclusions: Liability



-
- At this stage of development, only the fear of liability is real. But this is useful if it drives a better understanding of the bases for liability suits so that those exert essential influence on design and deployment plans/choices & communication of what drivers can reasonably expect from same.

S&I Conclusions: Liability



-
- Insurance companies can be expected to remain cautiously interested in new technologies. Efforts must continue to establish and maintain a dialog with them.
 - Automation must improve both intended and actual safety of travel in order to reduce liability exposure.

S&I Conclusions



-
- Maintain long-term vision as “driver” and yardstick for shorter-term research (see TRB Special Report 253 p. 1-7:

“DOT must continue to explore and examine transportation needs and solutions over longer time horizons and from system-level perspectives that encompass the vehicle, the highway environment and the driver”.



Recommendations for S&I Research

S&I Research Needs



-
- Identification, by stakeholder group, of critical transportation needs and concerns
 - Studies of actual vs. intended use of similar new technologies to identify potential liability exposures
 - Examine tradeoff between degree of automated control and anticipated liability exposure by different stakeholder groups

S&I Research Needs



-
- User Needs/Market Demand research
 - Complete analysis of Houston Demo survey
 - Develop computer model to determine consumer demand for IVI products/services (Information Accelerator)
 - price effects
 - rates of adoption
 - product/service substitutability

S&I Research Needs



-
- **Case studies -- a powerful tool for evaluating the potential benefits of IVI services in a real world setting -- should be an important part of IVI**
 - **Look to the regions that sponsored NAHSC case studies as potential IVI case study sites**
 - Use the methodology developed by NAHSC to solicit interest from new sites

S&I Research Needs



-
- **Ensure that case studies receive resources necessary for their success**
 - **Tailor case studies under IVI to target a specific vehicle platform -- e.g., Houston transit, Minnesota special vehicle**

S&I Research Needs



-
- Undertake multiple “generation” case studies for transit services where needs have been identified, e.g. Montgomery County, Seattle, et. al.
 - Engage transit labor in analysis of integrating services

S&I Research Needs



-
- Structured additional research re agency thinking and concerns, per IVI, Cooperative/Autonomous “follow on interviews”
 - Examine implications, impacts of new services on infrastructure owners and operators.
 - limitations of sensor, communications technologies, strategies for infrastructure support to overcome these limitations (costs/benefits/tradeoffs, deployability)

S&I Research Needs



-
- Identify non-technological requirements (e.g., driver licensing and enforcement, vehicle inspection and maintenance, pavement performance) for IVI services for each platform and generation
 - Need to develop new organizational skills, resources and structures

S&I Research Needs



-
- Develop cost/benefit tool that includes engineering and S&I issues for analysis of IVI services for diverse vehicle types and operational situations, recognizing dependence on user acceptance
 - Apply to case studies

S&I Research Needs



-
- **Begin generation 2, 3 issues research NOW to determine definition/need/scope of medium-long range services, e.g.:**
 - Sustainability of future transportation system in two Washington, D.C. corridors with/without new services
 - Regional traffic/air quality effects of an AHS on a major highway on Long Island.

S&I Research Needs



-
- Trends/Associated Costs/High Level Benefits of New Services as Counter-measures for Non-recurring Incidents & Resulting Delays in the Southern California ITS Priority Corridor (with focus on truck accidents)

S&I Research Needs



- **Basic long term, high risk research to address complex, persistent problems (e.g. congestion)**

Overall S&I Recommendation



- **This is a propitious time to seize the opportunity to craft a long term transition to SUSTAINABLE AND BALANCED TOTAL TRANSPORTATION SYSTEMS to alleviate death, injury, congestion and environmental degradation, and such a course should be vigorously pursued. This goal can only be attained with institutional and societal support.**

Cooperative vs. Autonomous Workshop
Appendix P : Needed Human Factors Research

Robert M. Hogan
Raytheon Systems Company

4/27/98

3:15 PM

Format:

- ◆ What was achieved by NAHSC Driver Role Team?
(See Hogan, 1998a)
- ◆ What should be done next?
(See Hogan, 1998b)
- ◆ Relevance to Autonomous vs. Cooperative?

Highest priority driver role issues identified and/or studied by Driver Role Team

- ◆ Inattentiveness due to lessened driving involvement
 - Directed review of vigilance and supervisory control literatures
 - Driver-in-loop simulator study at three levels of automation by STI
- ◆ Roles confusion / Time to attain situational awareness
 - Directed review of aviation psychology, manual tracking and failure detection literature by Damos Research Associates
 - Directed review of PSAs, particularly those involving Evolutionary Representative System Configurations, and automotive human factors
 - Study of driver role in two automated background collision avoidance systems by VPI
- ◆ Transfer of control / Rapid driver intervention
 - Would have been this year's top priority

Driver inattentiveness due to lessened driving involvement - What has been shown

- ◆ STI driver-in-loop simulator study: Head activity increased with time on task and with degree of automation. STI researchers (Allen, et al, 1998) attribute this to microsleeps. If their interpretation is correct, the results show that:
 - Driver alertness decrements can be measured in realistic situations, far more complex than usual laboratory vigilance task.
 - Driver alertness decreased appreciably within 1/2 hour of driving time on each task.
 - Alertness decreased more at the highest level of automation.
- ◆ Weakness of the argument: head activity may be only partially a result of microsleeps.

Driver inattentiveness due to lessened driving involvement: What should be done

- ◆ More complete analysis of the STI data, clarifying how inattentiveness varied with time on task for three different driving tasks. Should include
 - more detailed linking of frequency, magnitude and duration of head nodding with time on task
 - analysis of correlations of head activity with other measures collected (EOG, heart rate, driving performance, detection task timing).
- ◆ Pursue inattentiveness guidelines by similar driver-in-loop studies for key partially automated driver services.

Driver inattentiveness due to lessened driving involvement: Autonomous vs. Cooperative

- ◆ Our research suggests that inattentiveness is closely related to the lessening of active operator involvement:
 - Longitudinal controller as in ACC or cooperative ACC may reduce driver involvement, particularly on straight highway, probably more than conventional cruise control.
 - Higher levels of automated control (eg, steering control or lateral and longitudinal control) imply even less driver involvement, maybe greater inattentiveness.
- ◆ Not clear how inattentiveness would be related to degree of cooperation among vehicles and infrastructure.
- ◆ Cooperative technologies might provide ways of signaling to, or about, an inattentive driver.

Roles confusion / Time to attain situational awareness: What was achieved

- ◆ Driver Role Team looked at:
 - Single vs. multiple warnings (Section 10.4.6.4.2 of Hogan, 1998a)
 - Single vs. multiple modes of control (e.g., independent lateral and longitudinal control, or independent warning and automated collision avoidance systems) (Dickerson, et al, 1994, Section 10.4.6.4.1 of Hogan, 1998a)
 - Single vs. multiple overrides of control modes, considered in the context of background collision avoidance systems (Gellatly, et al, 1998, Hogan, 1998b).
 - Inadvertent or erroneous deactivation of background collision avoidance systems (Hogan, 1998b).

Roles confusion / Time to attain situational awareness: What should be done

- ◆ Each of these topics needs more detailed study
- ◆ A useful design principle:
 - *If operator intervention might be required, compare the cognitive processing time to achieve situational awareness vs. the time available in critical traffic situations.*
 - Applying this principle will guard against a central problem with higher levels of automation design noted in current literature:
 - » “The amount of information that is potentially available to the operator has increased; but its quality does not match the mechanisms and limitations of human information processing. As a consequence, the gap between available and required feedback is growing” (Sarter, Woods, & Billings, 1998).

Roles confusion / Time to attain situational awareness: Autonomous vs. Cooperative

- ◆ Decreasing the operator's active involvement, by either autonomous or cooperative technologies, can make driver situational awareness more problematic:
 - If there are speed and headway maintenance and roadway-to-vehicle or vehicle-to-vehicle speed commands, the driver's ability to intervene appropriately may be degraded when interfacing with the on board ACC system due to the unexpected or hard to understand nature of externally generated commands (Dickerson, et al, 1994).
- ◆ Impact of lessened driver intervention capability, due to less adequate situation awareness, must be weighed against improved speed/appropriateness of automated response.

Transfer of Control / Rapid Driver Intervention: What was considered?

- ◆ Issues which would have been addressed this year:
 - Transition must be smooth, quick, and natural to the driver. The driver should understand what is happening and why.
 - Interference with vehicle control due to transfer between manual and automatic modes should be studied. The study could include possible complicating factors like roles confusion, inadvertent deactivation, or judgment error, so the issue overlaps with driver situation awareness.
 - Driver must be ready to receive control when it is relinquished by an automated mode.
 - When should driver override an automated mode? How reliable will correct override be under time constraints?

Transfer of Control / Rapid Driver Intervention: What should be done?

- ◆ Impact of transfer of control in various configurations can be studied by relatively direct extension of driver modeling methods (Levison & Cramer, 1995) developed to evaluate the impact of in-vehicle auxiliary tasks.
- ◆ Driver readiness test: Gradual transfer of driving authority back to driver contingent on driver demonstrating adequate control was considered for AHS Check-out by Turan, et al, 1995. This idea is worth studying in other contexts.
- ◆ Pursue idea of integrating driver override inputs with what system thinks is safe.
- ◆ When should driver override? Open Loop Action Theory (Sheridan, 1991) seems directly relevant, but the theory requires development as well as application. OLAT has similarities to Signal Detection Theory.

Transfer of Control / Rapid Driver Intervention: Cooperative vs. Autonomous

- ◆ Transfer of control and rapid operator intervention are obvious concerns whose importance may increase with extent of partial automation (i.e., with degree of system independence from driver control). The concerns become less relevant for levels of automation where rapid operator intervention is not required.
- ◆ Relationships to degree of system cooperation (among vehicles and infrastructure) are less obvious but:
 - Cooperative ACC (or other cooperative concept) with dependence on location of more than one preceding vehicle can make control smoother (e.g., Sheridan, 1991). Further, the idea of integrating driver inputs with what system thinks is safe may make more sense in a cooperative system, which can consider a wider traffic environment.

References

- ◆ Allen, R.W., Parseghian, Z., & Page, B. (1998). The Influence of Automated Driving Conditions on Driver Vigilance. Systems Technology, Inc., TR 2588-1, Hawthorne, CA.
- ◆ Dickerson, J.A., Lai, M.C., Ioannou, P.A., Chien, C.C., Kanaris, A., Damos, D., Smith, D., Shulman, M., & Eckert, S. (1994). Precursor Systems Analysis for Automated Highway Systems: Lateral and Longitudinal Control Analysis. University of Southern California, Center for Advanced Transportation Technology. National Technical Information Service, Springfield, VA.
- ◆ Gellatly, A.W., Dingus, T.A., & Hanowski, R.J. (1997). Human Factors Assessment of Two Background Collision Avoidance Concepts, Center for Transportation Research, Virginia Polytechnic University and State University, Blacksburg, VA.
- ◆ Hogan, R.M. (1998a). Driver Involvement Analyses, Section 10.4.6 in NAHSC C3 Interim Report, U.S. Department of Transportation, Federal Highway Administration, 6300 Georgetown Pike, Room T-201, McLean, VA.
- ◆ Hogan, R.M. (1998b). Evaluate Human Factors Issues: The STI and VPI Studies, Section A.2.5 in NAHSC Termination Task, U.S. Department of Transportation, Federal Highway Administration, 6300 Georgetown Pike, Room T-201, McLean, VA.

References (cont'd)

- ◆ Levison W.H. & Cramer, N.L. (1995), Description of the Integrated Driver Model, Federal Highway Administration, RD-94-092. National Technical Information Service, Springfield, VA.
- ◆ Sarter, N.B., Woods, D.D., & Billings, C.E. (1998). Automation Surprises. In G. Salvendy (Ed.), *Handbook of Human Factors and Ergonomics (2nd Ed.)*. John Wiley & Sons: New York.
- ◆ Sheridan, T.B. Human Factors of Driver-Vehicle Interaction in the IVHS Environment, National Highway Traffic Safety Administration, DOT HS 807 737. National Technical Information Service, Springfield, VA.
- ◆ Turan, L., Ioannou, P., Safonov, M.G., Smith, D., & Damos, D. (1995). Precursor Systems Analyses of Automated Highway Systems: Automated Check Out. University of Southern California, Center for Advanced Transportation Technologies. National Technical Information Service, Springfield, VA.

Appendix Q: Critical Enabling Technologies

Chuck Thorpe

IVI Matrix

This briefing correlates to IVI in the areas indicated:

<u>AREA OF CONCERN</u>	Rear End	Road Dep.	Passing	Intersect.
	<u>C.A.</u>	<u>C.A.</u>	<u>C.A.</u>	<u>C.A.</u>
Sensing	X	X	X	X
Warning and Control	X	X	X	X
Infrastructure	X	X	X	X
Driver-Veh. Interface	X	X	X	X
User Acceptance				
Benefits	X	X	X	

NAHSC CET Technology Categories

- Identified in Task B2 (Wei-Bin Zhang)
- Developed under B3 (Chuck Thorpe)
- Team included Dan Brady, John Castro, Chin-Yao Chen, Ron Hearne, Bakhtiar Litkouhi, Fred Mangarelli, Nick Panebianco, Ashok Ramaswamy, Jim Reynolds, Bill Stevens, Chuck Thorpe
- Meetings and telecons, but decentralized
- Substantial contracting and outreach

Tech Team Tasks

- On-Vehicle Sensing - Longitudinal Separation Sensing (GM)**
- On-Vehicle Sensing - Obstacle Detection (GM)**
- On-Vehicle Sensing - Lateral Position Sensing & Algs. (PATH)**
- On-Vehicle Sensing - Vehicle Lateral Position (PATH)**
- On-Vehicle Sensing - Motion Sensing (CMU)**
- On-Vehicle Sensing - Absolute Positioning For AHS (CMU)**
- On-Vehicle Sensing - Vehicle Sys Status (inc. braking cap.) (GM)**
- On-Vehicle Sensing - Driver / Surface Condition (CMU / GM)**

More Tasks

- Roadway And Infrastructure Sensing - Environment (LMC)**
- Roadway And Infrastructure Sensing - Macro Traffic Condition (Caltrans)**
- Roadway And Infrastructure Sensing - Micro Traffic Conditions (Caltrans)**
- Roadway And Infrastructure Sensing - AHS Obstacle Detection (CMU)**
- Actuators (Cars, Trucks, Buses) - Steering (GM)**
- Actuators (Cars, Trucks, Buses) - Braking (GM)**
- Actuators (Cars, Trucks, Buses) - Throttle (GM)**

More Tasks

- Communications - Vehicle-To-Vehicle (Hughes)**
- Communications - Vehicle-To-Roadside (Hughes)**
- Communications - Roadside-To-TMC (Hughes)**
- Communications - On-Board Vehicle (PATH)**
- Processing - On-Board (CMU)**
- Processing - Infrastructure And TMC (PB)**
- Algorithms - Integrated Control (PATH)**
- Algorithms - Check-In And Merging (PATH)**
- Algorithms - Check-Out And De-Merging (CMU)**
- Algorithms - Obstacle Avoidance (CMU)**
- Algorithms - Exit Management (PB)**

More Tasks

Algorithms - Traffic Flow Management (PB)

Algorithms - Software Safety (PATH)

Infrastructure And Configuration - Traffic Operations And Maintenance (Caltrans)

Infrastructure And Configuration - Roadway, Lane And Barrier Designs (Bechtel)

Infrastructure And Configuration - AHS-Specific Construction (Bechtel)

Infrastructure And Configuration - AHS-Specific Maintenance And Rescue Vehicles (Caltrans)

Infrastructure And Configuration - Obstacle Prevention (PATH)

Problem: Underlying Technology Need

- Subproblems: What do we care about?
- Possible Solutions: NAHSC technology categories
- NAHSC Activities: specific research tasks
- Comments: balance of cooperative vs. autonomous
- Recommendations: research that should be continued, dropped, expanded, or initiated

Safety

	Other Veh.	Obst.	Lane Pos	Control	Pos + mtion	Brake	Comm	Relia bility	Misc.	Clutter
Rear End	✓		✓	✓	✓	✓	✓	✓	✓	✓
Road Dep			✓	✓	✓	✓	✓	✓	✓	✓
Lane Chnge	✓		✓	✓	✓		✓	✓	✓	✓
Inter-Sect	✓			✓	✓	✓	✓	✓	✓	✓
Rail-Road Xing				✓	✓	✓	✓	✓	✓	

Safety (cont'd)

	Other Veh.	Obst.	Lane Pos	Control	Pos + mtion	Brake	Comm	Relia bility	Misc.	Clutter
Vision Enhce	✓	✓	✓					✓	✓	✓
Loc-spec					✓	✓	✓	✓	✓	
Coll Notif					✓		✓	✓	✓	
Smart restrnt	✓	✓						✓	✓	

Safety Impacting

	Other Veh.	Obst.	Lane Pos	Control	Pos + mtion	Brake	Comm	Relia bility	Misc.	Clutter
Nav/ Rout					✓		✓	✓	✓	
R-T traffic					✓		✓		✓	
Driver Conf.									✓	

Commercial Vehicle

	Other Veh.	Obst.	Lane Pos	Control	Pos + mtion	Brake	Comm	Relia bility	Misc.	Clutter
Stability				✓	✓	✓		✓	✓	
Driver Cond.			✓							
Vehicle Diag.										
Cargo ID										
Auto Transact.							✓			
Safety recorder	✓	✓	✓							

Supporting

	Other Veh.	Obst.	Lane Pos	Control	Pos + mtion	Brake	Comm	Reliability	Misc.	Clutter
Low Friction					✓	✓	✓			
Long Ctrl	✓	✓		✓	✓	✓	✓	✓	✓	✓
Lat Ctrl	✓		✓	✓	✓		✓	✓	✓	✓

Problem 1: Know Where Other Vehicles Are

- Subproblems
 - position relative to you and to road
 - stopped vehicles (q.v. Steve Carlton, Bill Stevens)
 - vehicle motion prediction

Possible Solutions:

- On-vehicle sensing - Longitudinal Separation Sensing
- On-vehicle sensing - Lateral Position Sensing and Algorithms
- Infrastructure and Configuration - Roadway, Lane, And Barrier Designs
- Communications - vehicle to vehicle

NAHSC Activities:

- CMU radar
- CMU ladar
- CMU capaciflector
- CMU sonar
- Delco radar
- PATH stereo
- LMC radar
- Road sensing and modelling
- Driver monitoring and prediction
- Related to DASCAR, VME, OMC work

Introduction

Range sensors are important for collision free autonomous navigation.

- Maximum range between 100 and 300 metres.
- Can operate at night and under adverse weather conditions (fog, rain, snow).
- Longitudinal resolution between 0.1 and 1 m.
- Lateral resolution must be able to discriminate between vehicles in different lanes for Highway scenario.

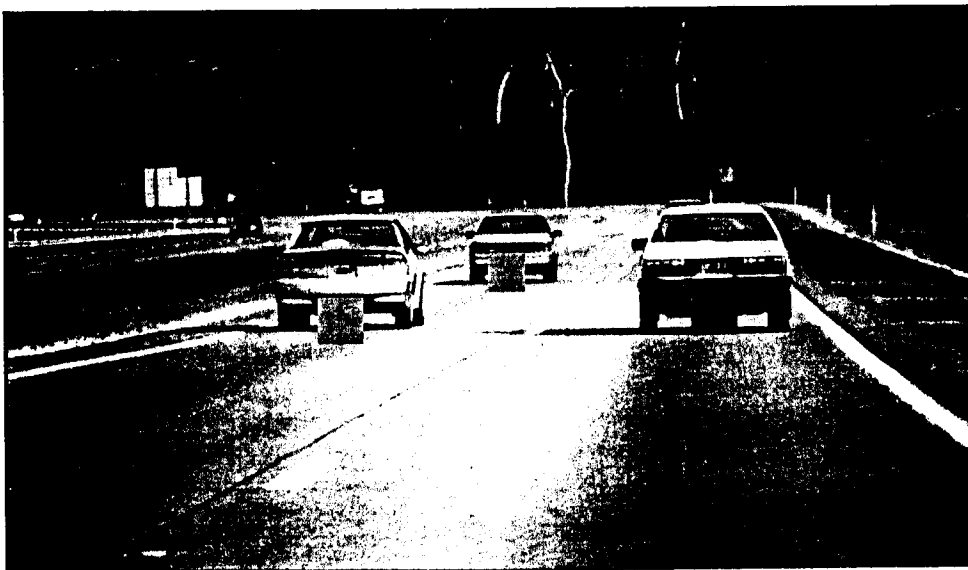

Sensor Design Concept

Geometry

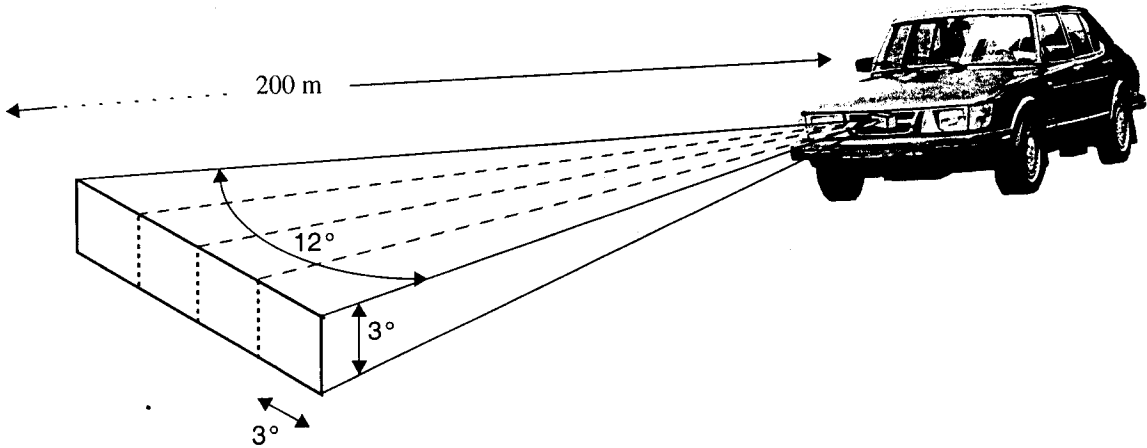

Horizontal Area coverage:

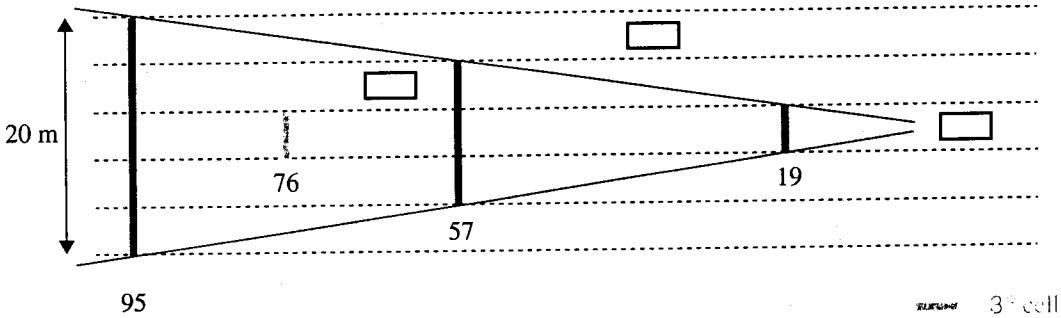

Testbed Vehicle

Navlab 5:



Block Diagram

FMCW Millimeter Wave Radar

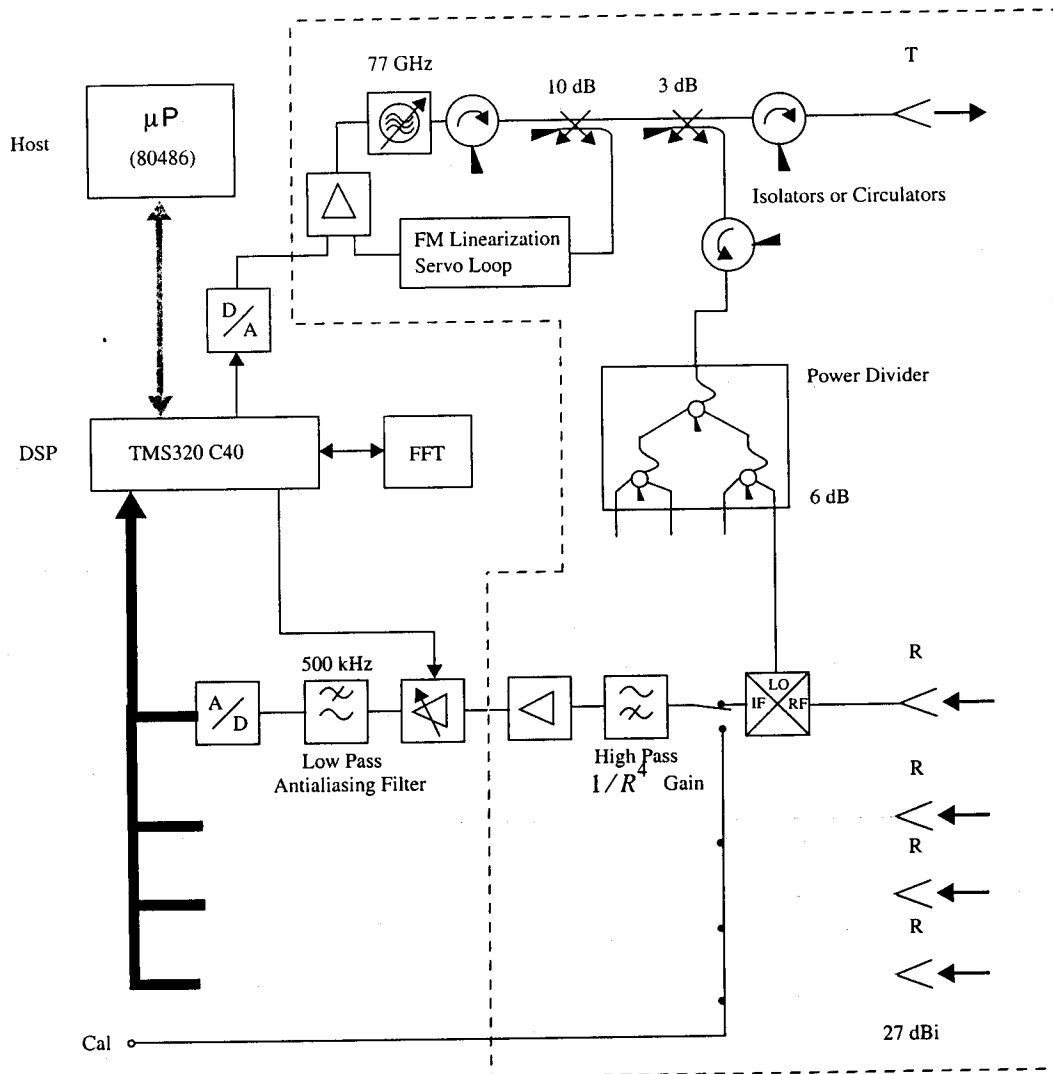

Specifications

- Modulation Type: FMCW

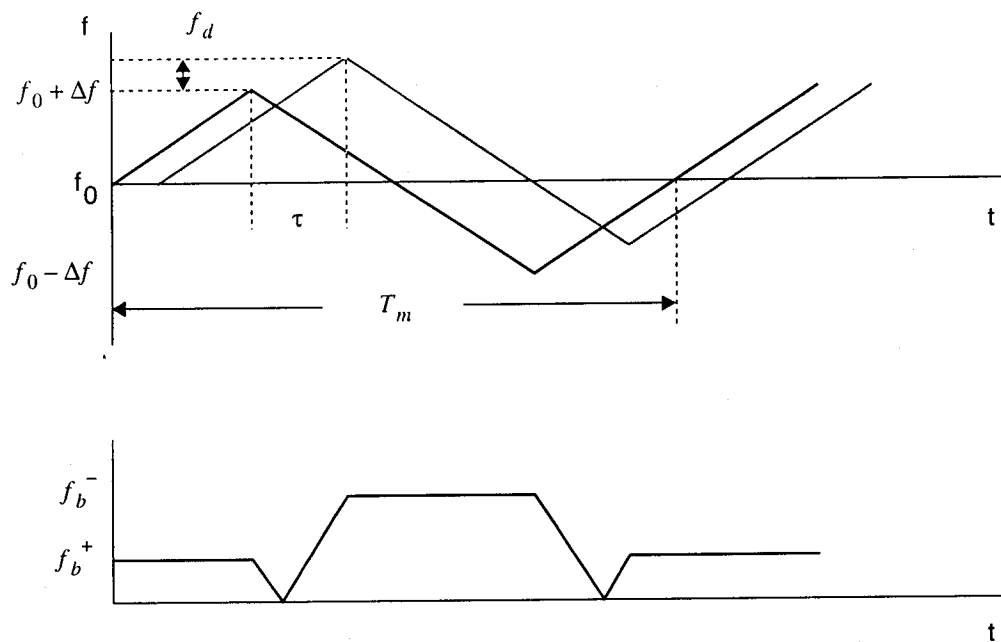

- Carrier Frequency: 76.5 GHz
- Swept Frequency: 300 MHz
- Maximum IF: 500 kHz
- Modulation Cycle: 625 Hz (1.25 kHz)

Radar Range Linearity

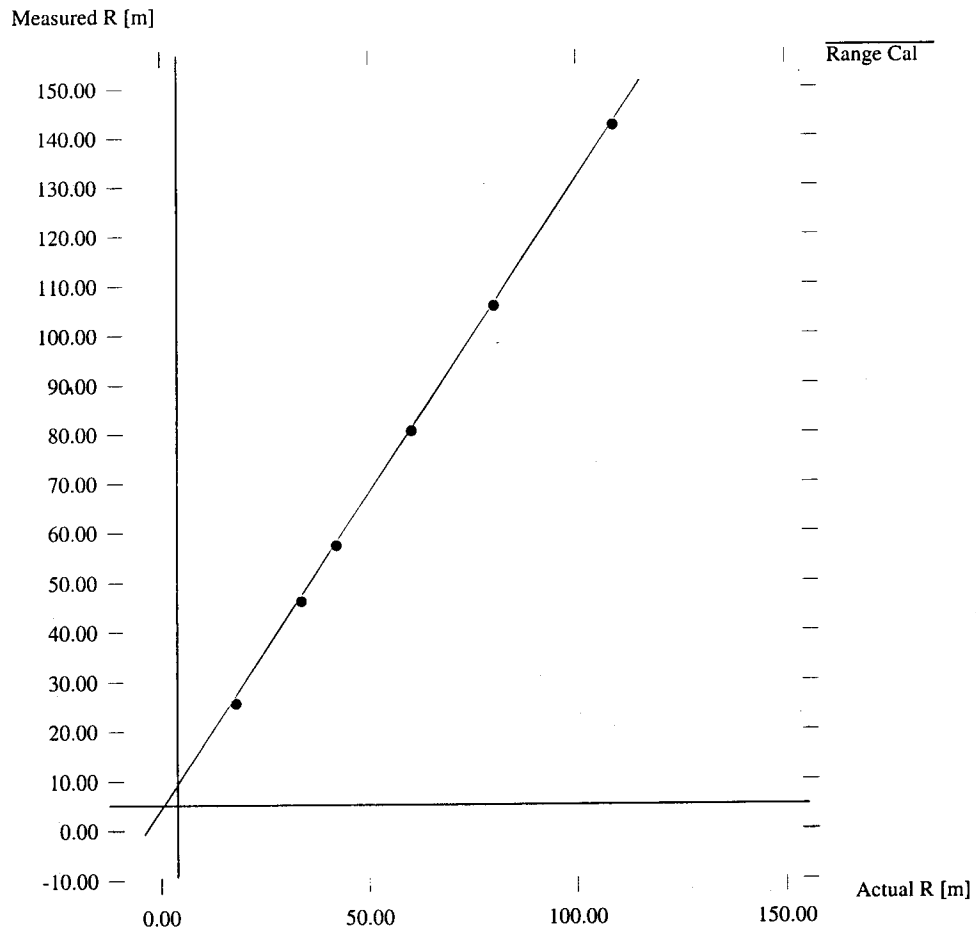

Radar Accuracy and Repeatability

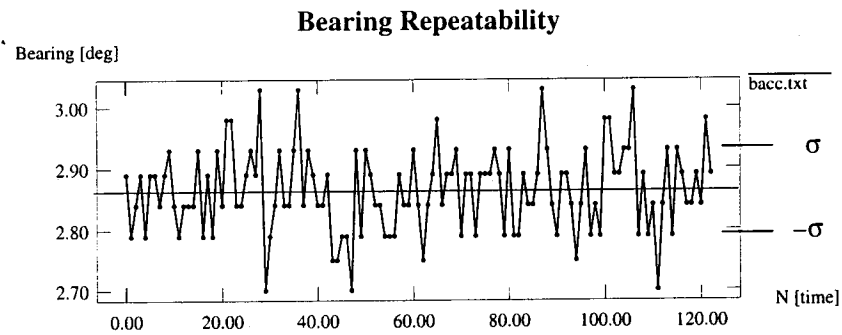
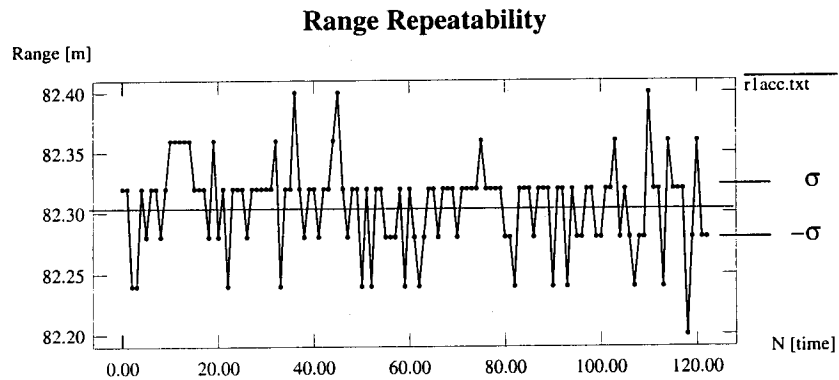

Statistics on Range and Bearing Measurements

	Bearing [deg]	⁽¹⁾ Range [m]
number of samples N	123	123
mean \bar{x}	2.86	82.31
standard deviation σ	0.0685	0.0364

Traffic Scene

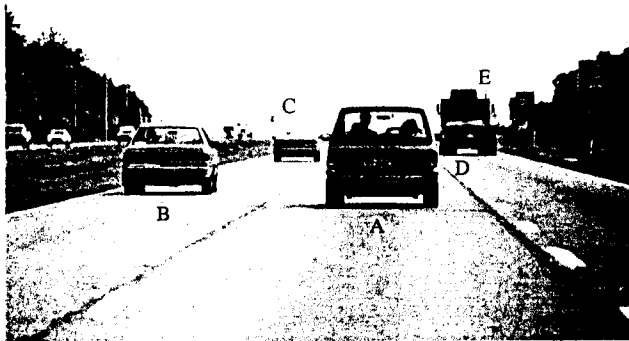

Traffic Scene

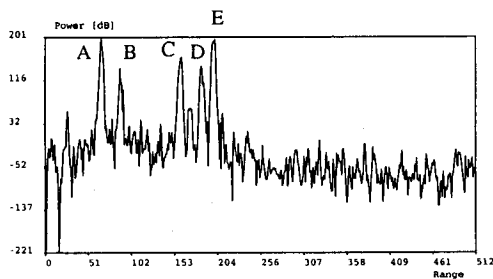
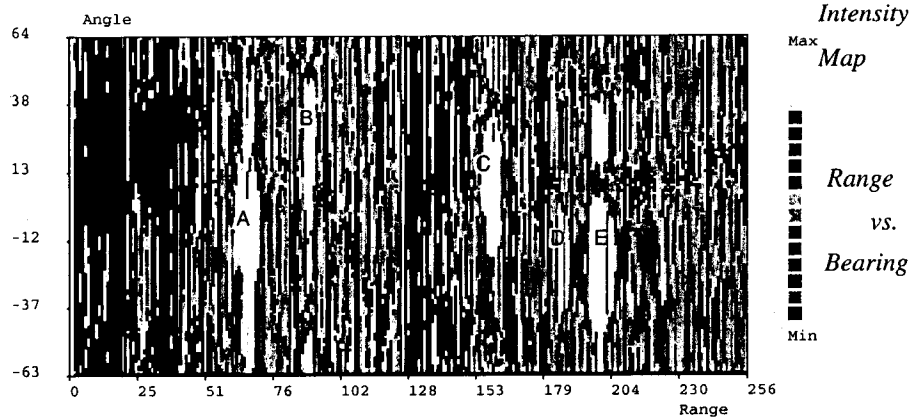

Range

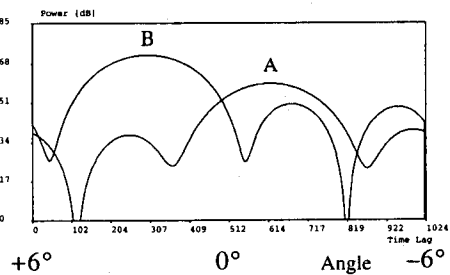

Bearing of two closest targets

Integration with road geometry

Problem Situations:

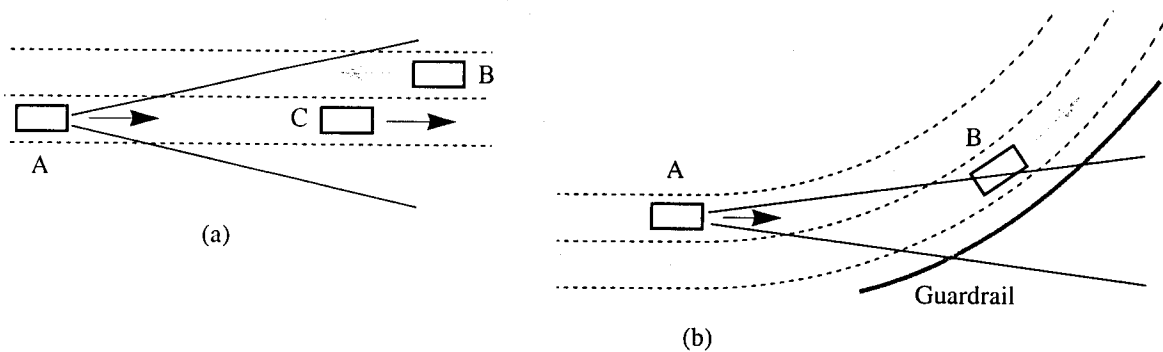

For (a):

- Need to resolve 2.3° if vehicles B and C are 100 m distant from A.

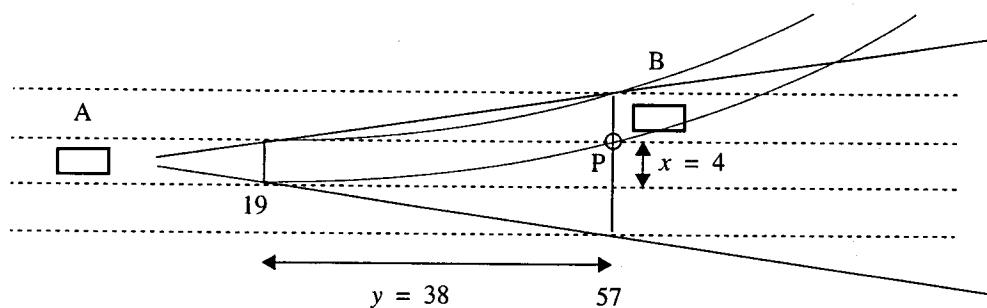

- Radius of curve = 182.5 m

RALPH

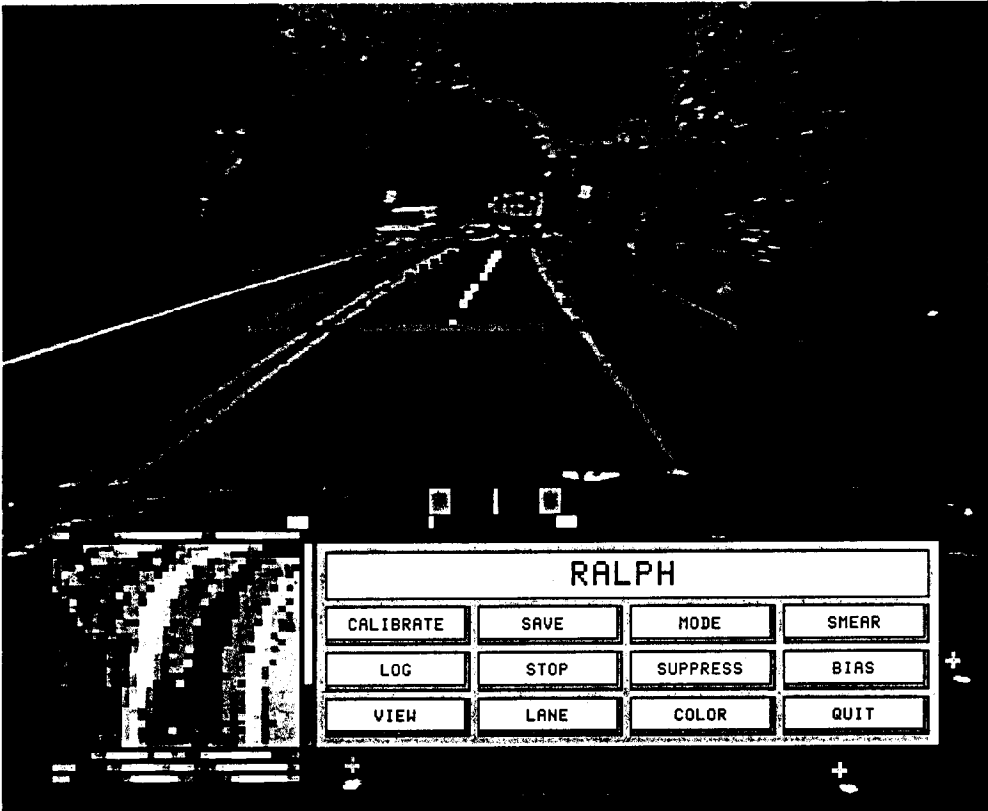

Integration with road geometry

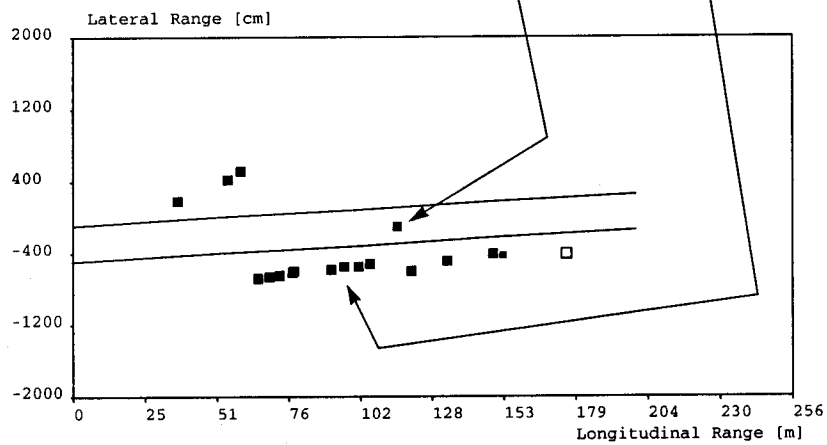
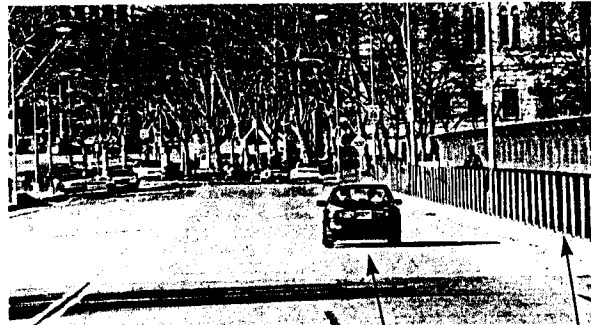

Tracking multiple vehicles from stationary point

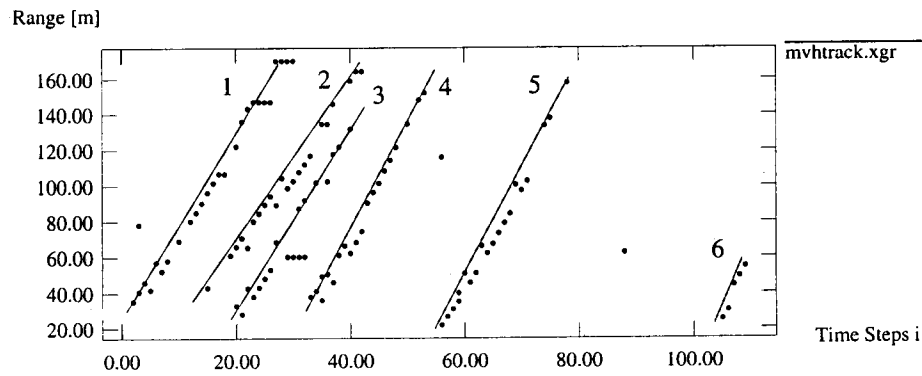



(a)



(b)

Figure 1: Interior and exterior views of our test vehicle.



(a)



(b)

Figure 1: Interior and exterior views of our test vehicle.

Navlab 6

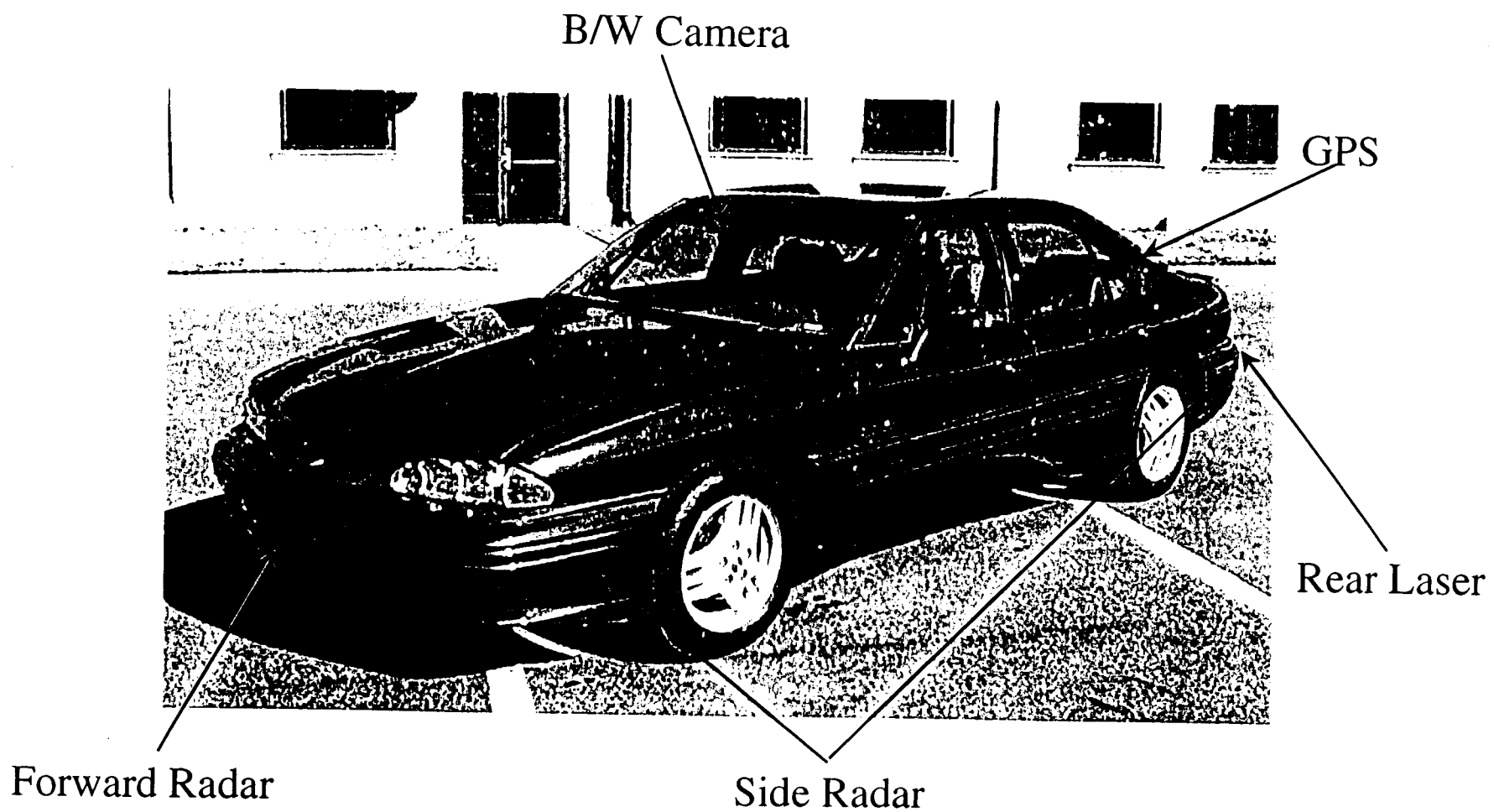

Sensors

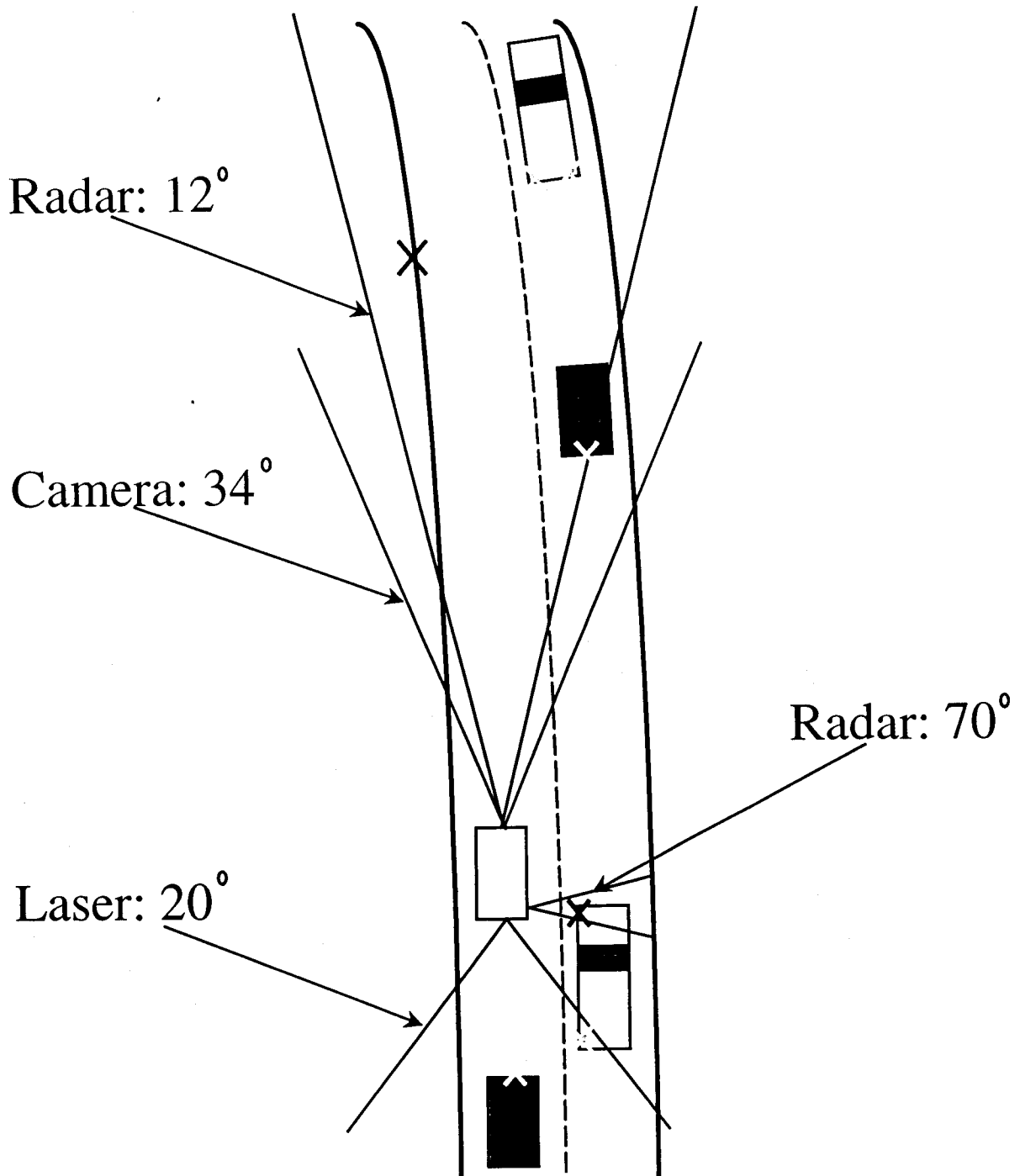

Demo System

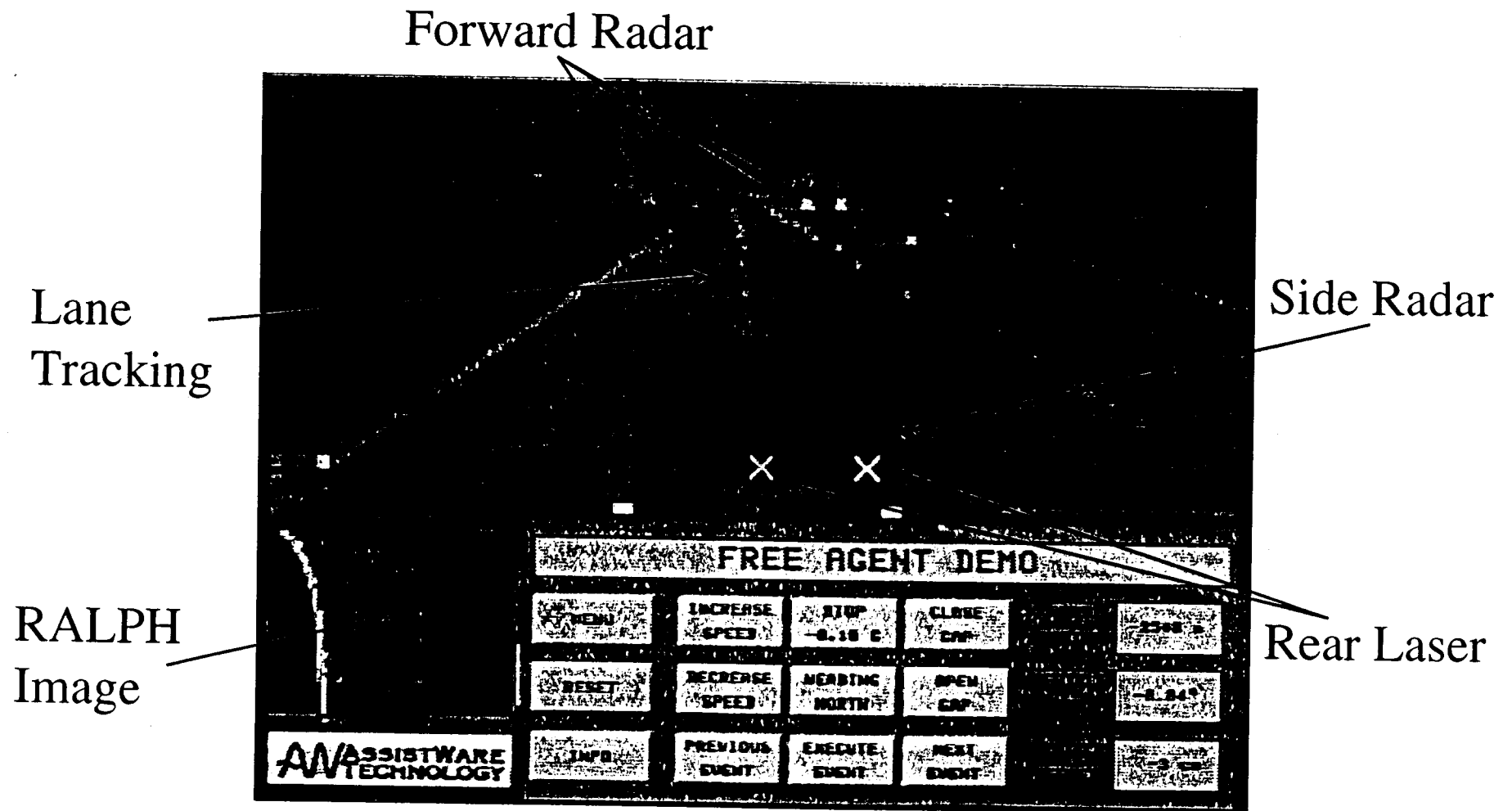

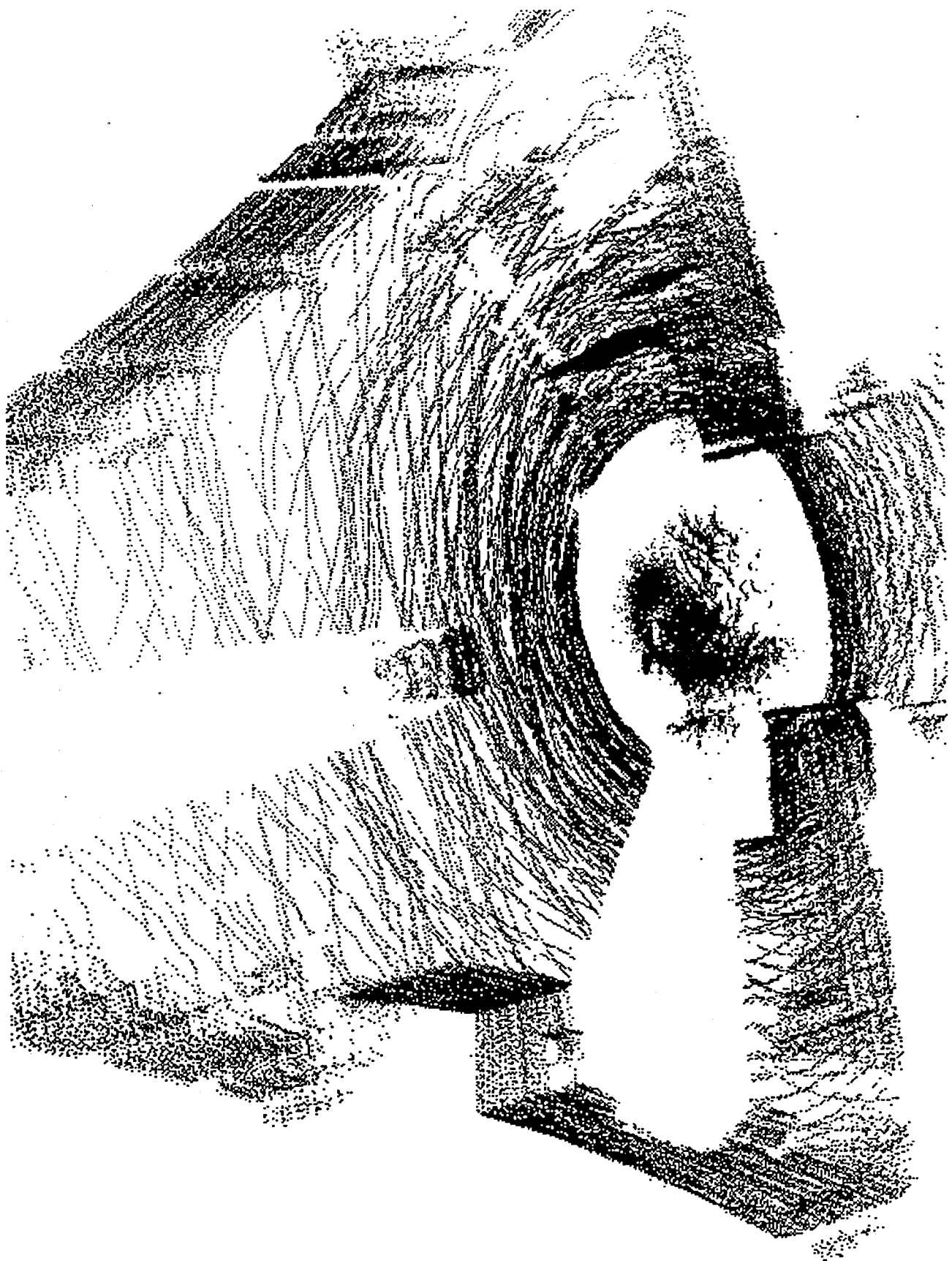

Raw Range Image

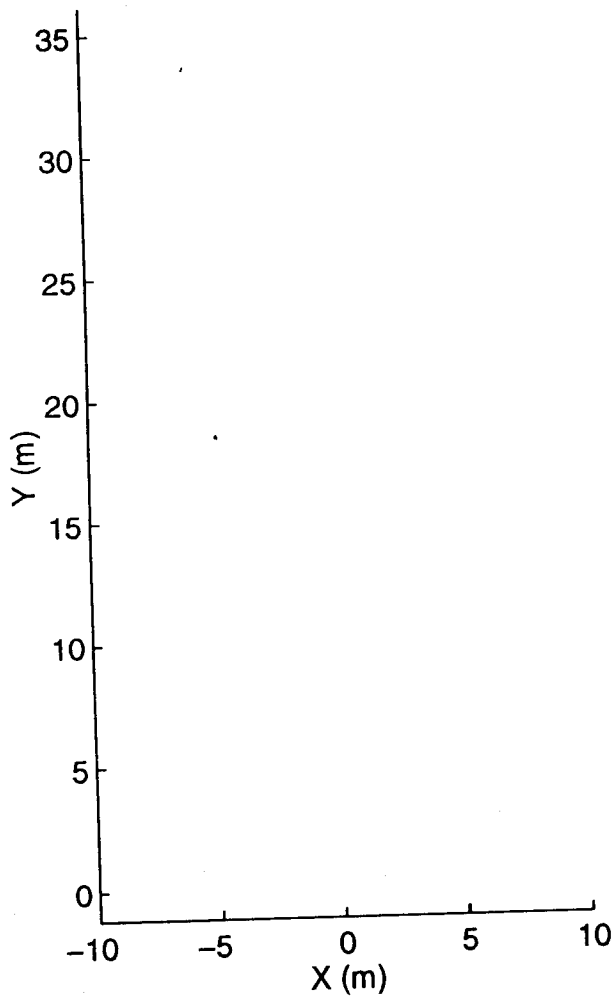

Line Detection

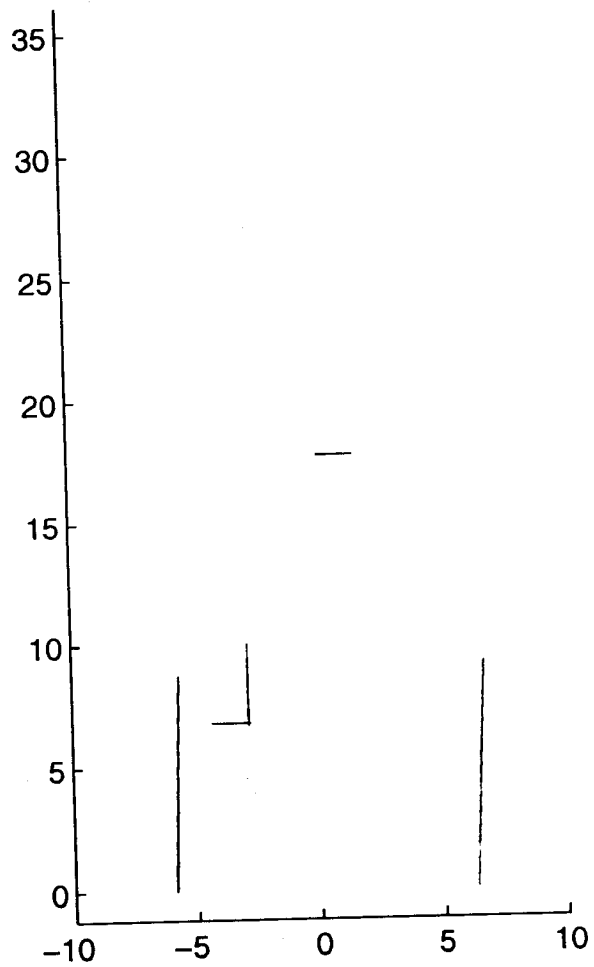

Car Detection

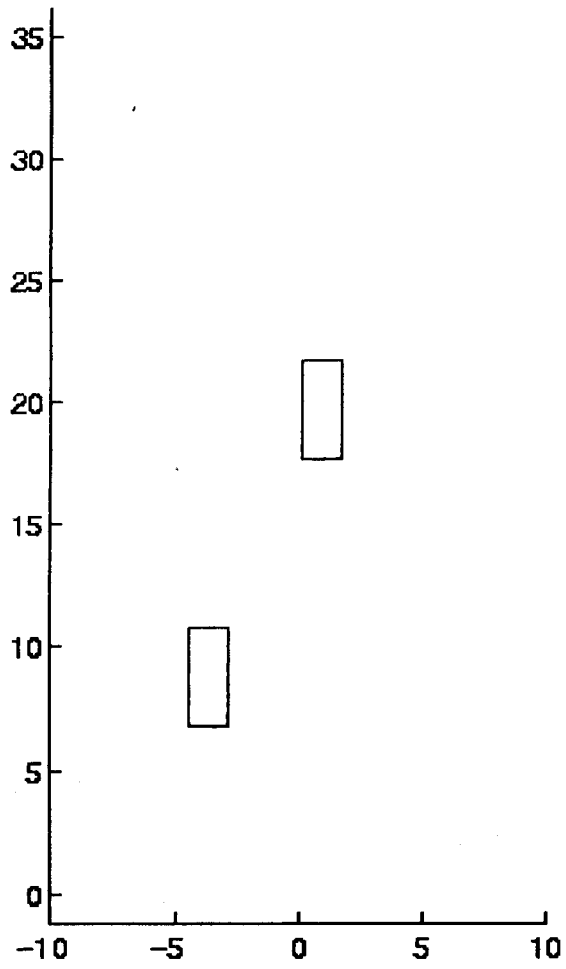

Car Tracking

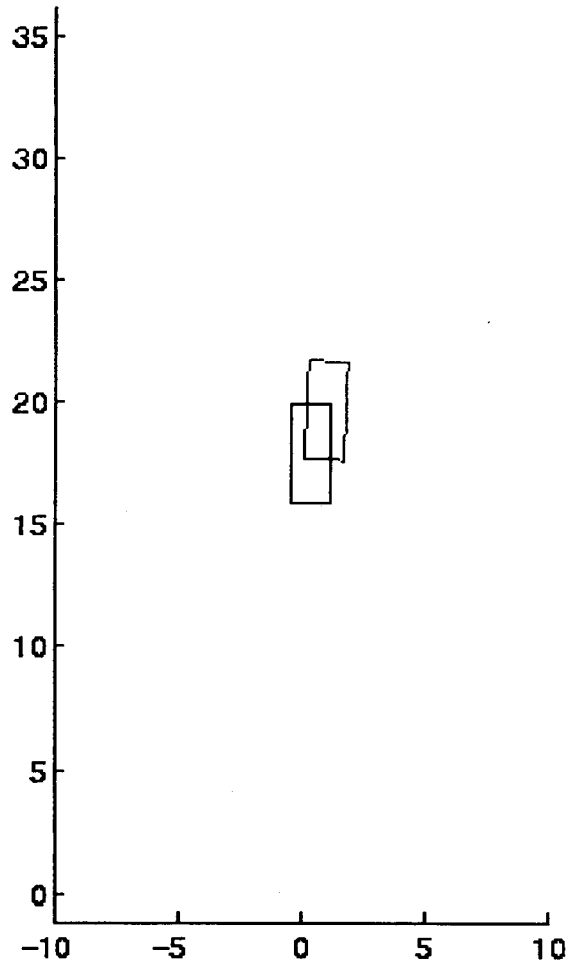

frame 512

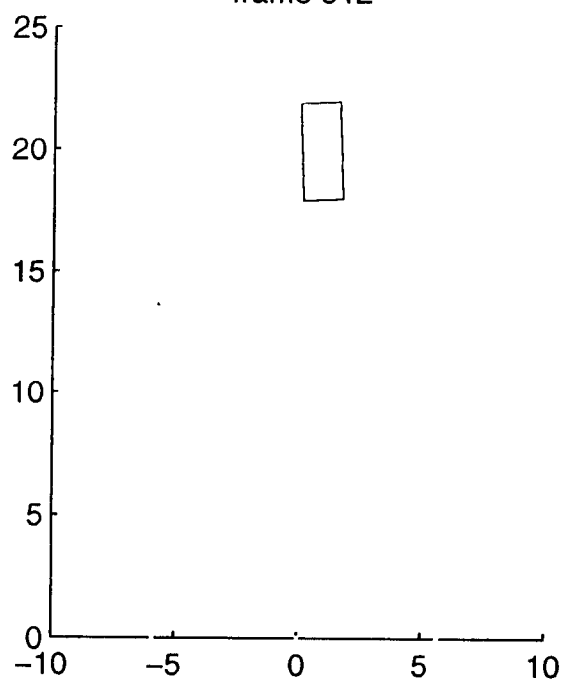

frame 513

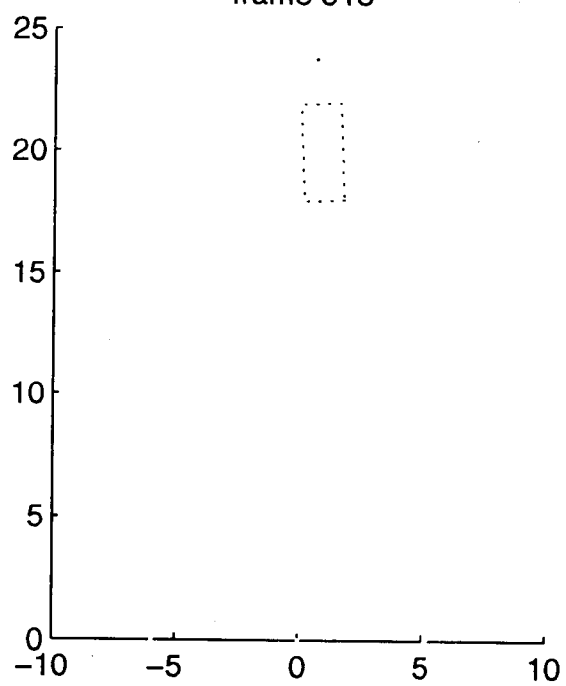

Trajectory of the Tracked Car

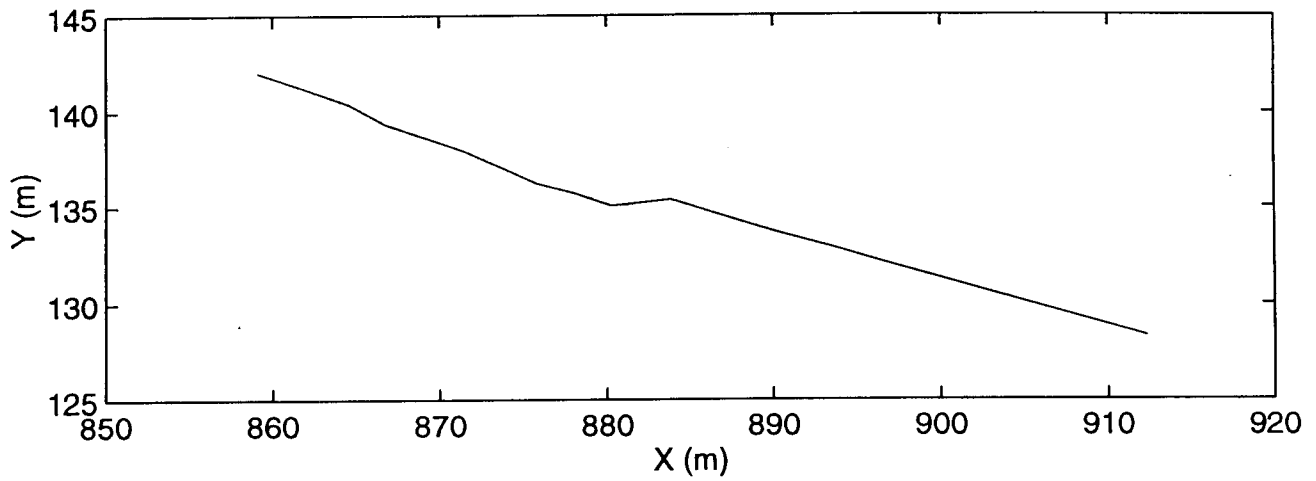

Model Probabilities

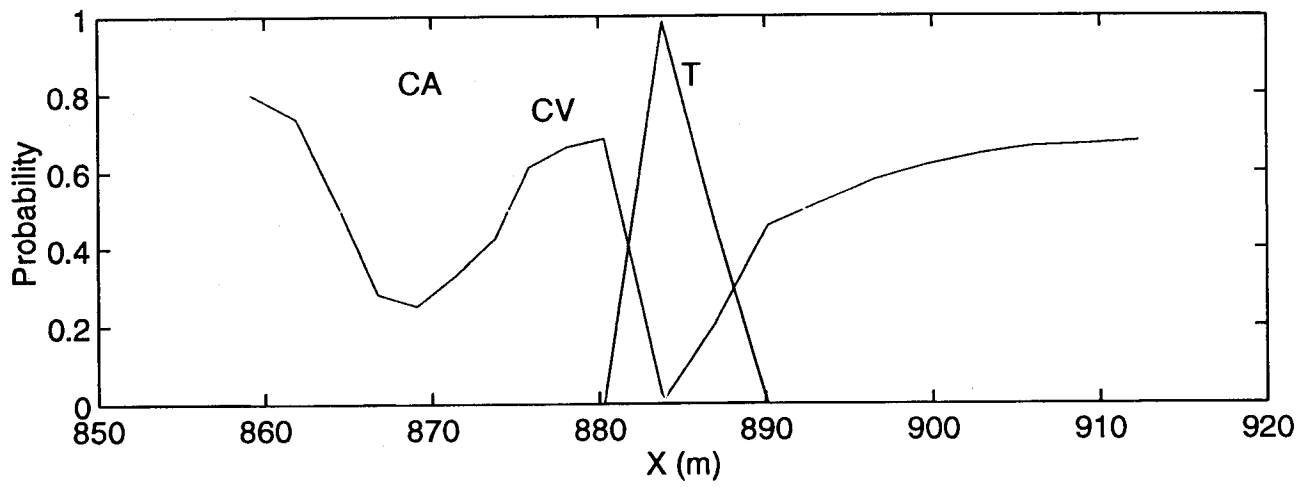

Differences Between NL8 Drivers

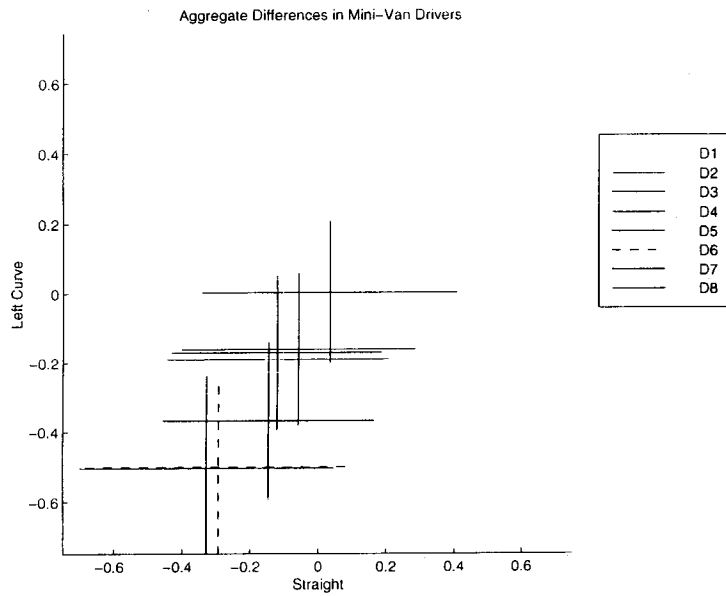

Differences Within Truck Drivers

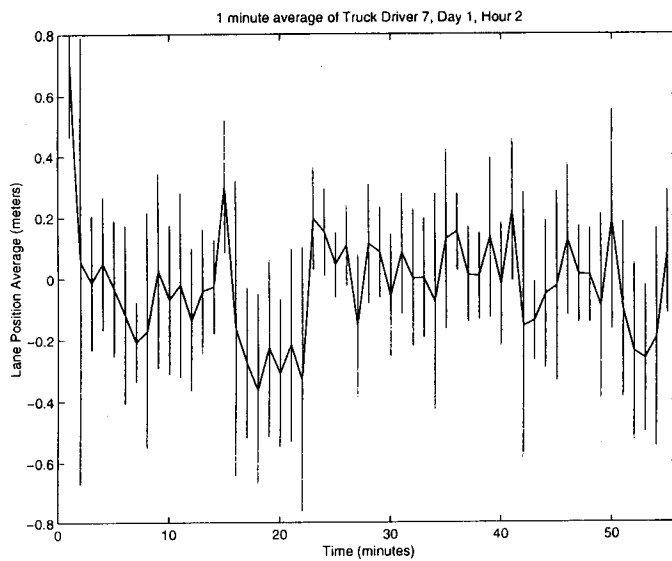

Lane Change D

- Warning Time Gain = 1.09s

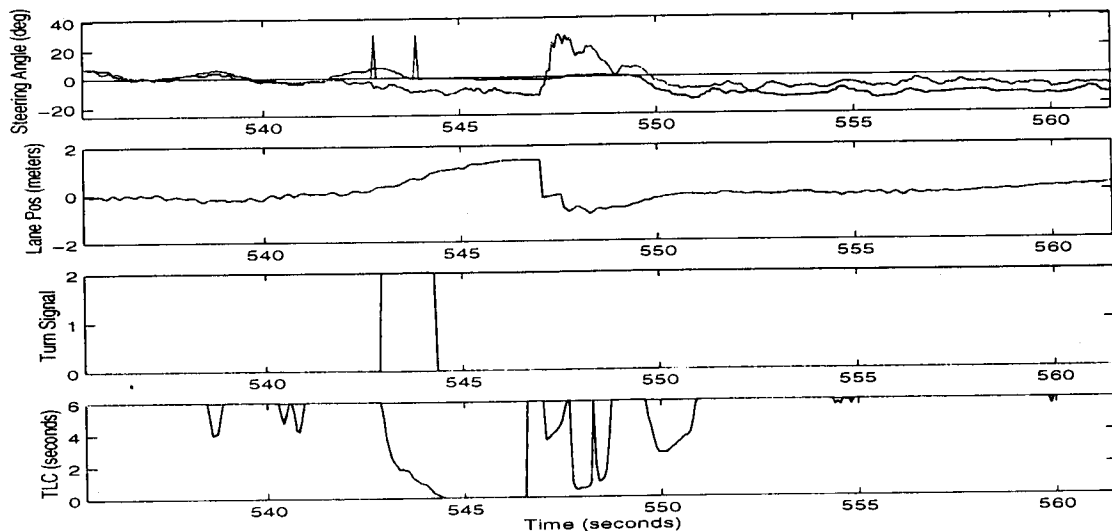

- Relatively slow drift caused by steering wheel impulse.
- TLC doesn't catch on because lateral velocity is slow.
- Similar to ROR caused by inadvertent steering wheel motion.

Comments:

- Almost all solutions are vehicle-based
- Help can come from:
 - Retroreflectors, including OSU FSP ideas
 - Knowing road alignment, either from map or from sensing
 - Comm (either all vehicles or some)
 - Roadway design for sensor visibility with restrictions on low-radius curves for non-steering radar

Recommendations 1:

- Continue work on integration of vehicle sensing and road modeling
- Continue work on driver behavior modeling and prediction
- Start work on semi-passive beacon/tag for ACC

Problem 2: Handling Obstacles

- Subproblems:
 - Decreased driver vigilance from ACC
 - Contribution to variety of accident types
 - Various kinds of targets:
 - deer vs. cars
 - moving vs. stationary
 - metallic vs. non-metallic
 - Obstacle detection on curved roadways

Possible Solutions:

- On-vehicle Sensing - Obstacle Detection
- Roadway and Infrastructure Sensing - AHS Obstacle Detection
- Infrastructure and Configuration - Roadway, Lane, and Barrier Designs
- Infrastructure and Configuration - Obstacle Exclusion

NAHSC Activities:

- Hughes Obstacle statistics collection
- GM obstacle effects work
- UMass sensor fusion
- GM sensor fusion
- U Mich polarimetric radar
- CMU ladar
- CMU stereo
- Misc. fence / barrier cost est.
- Bechtel roadway alignment for visibility

Stereo Methods

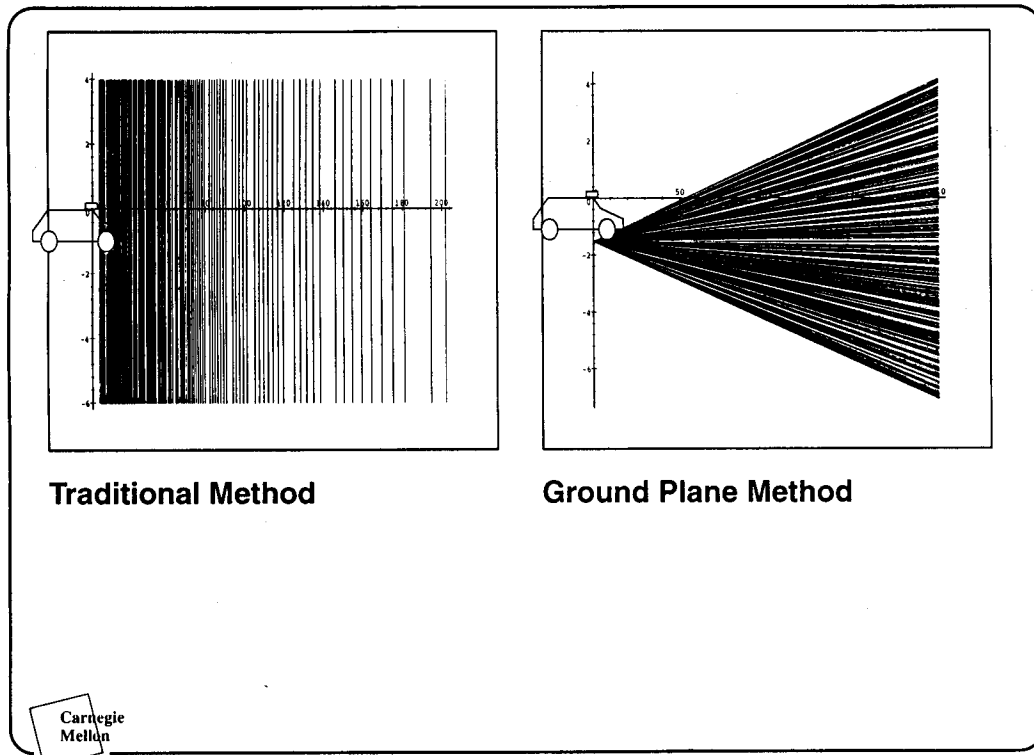

Stereo for Obstacle Detection - Identifying the road

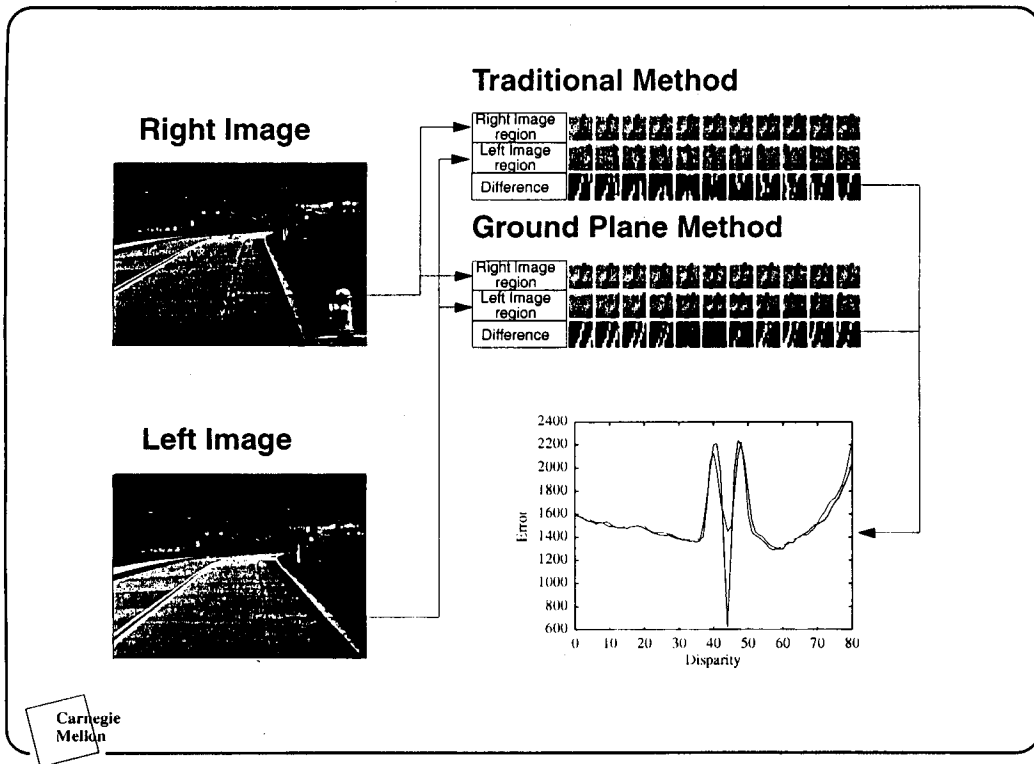

Stereo Obstacle Detection Method

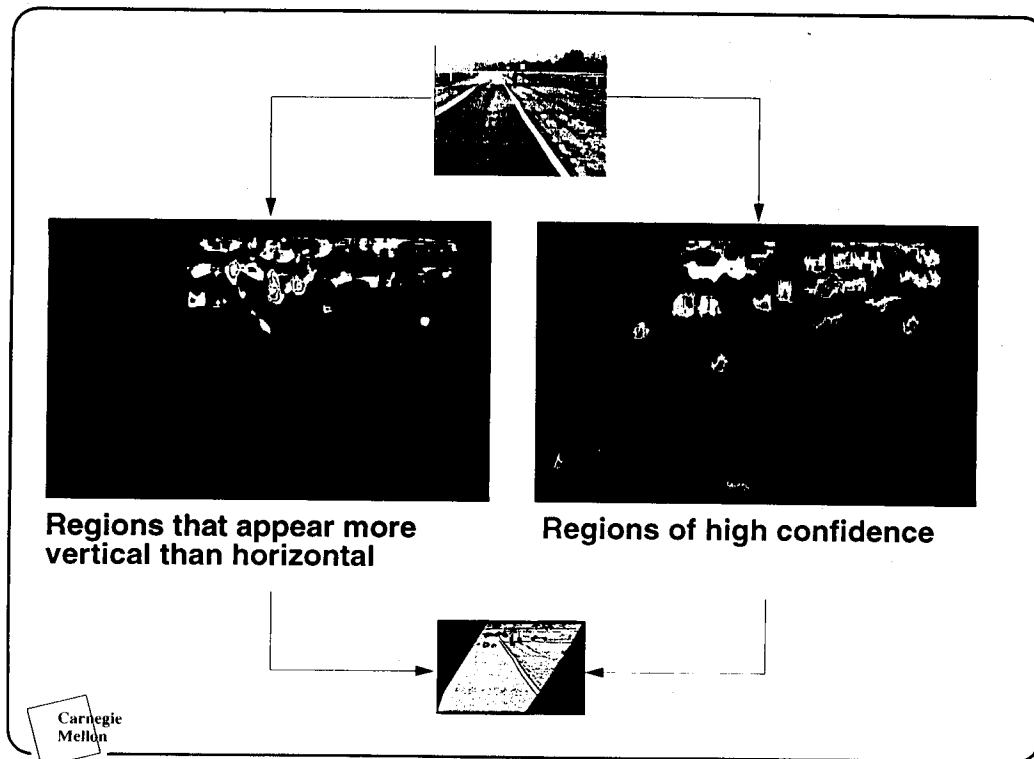

Stereo for Obstacle Detection - Identifying Obstacles

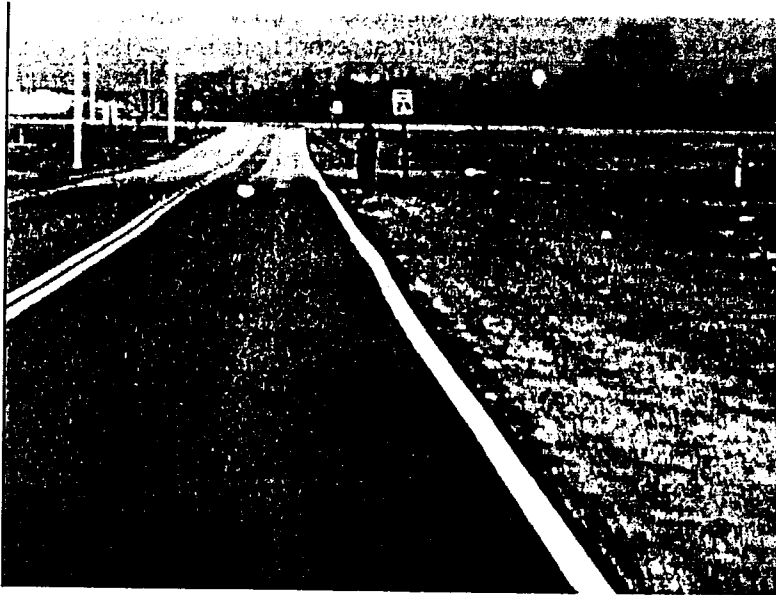

Original image with 2
15cm tall obstacles 100m
ahead

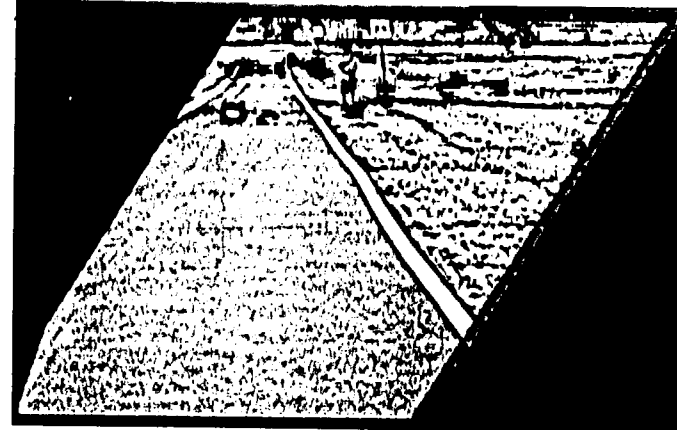

Detected obstacle
regions shown in red

Range

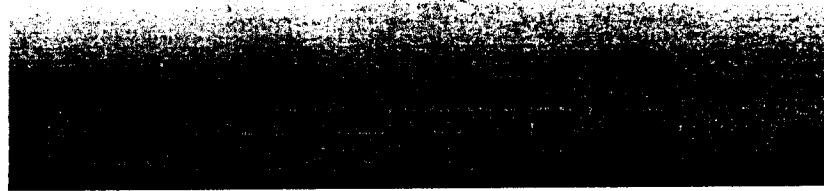
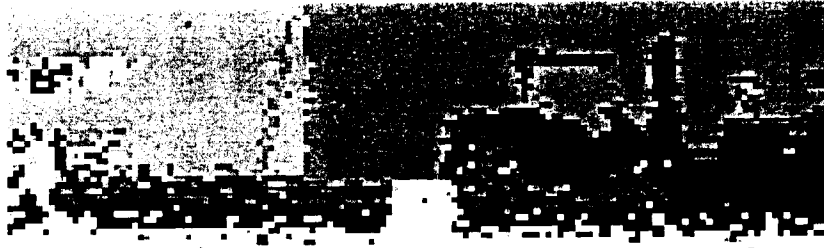
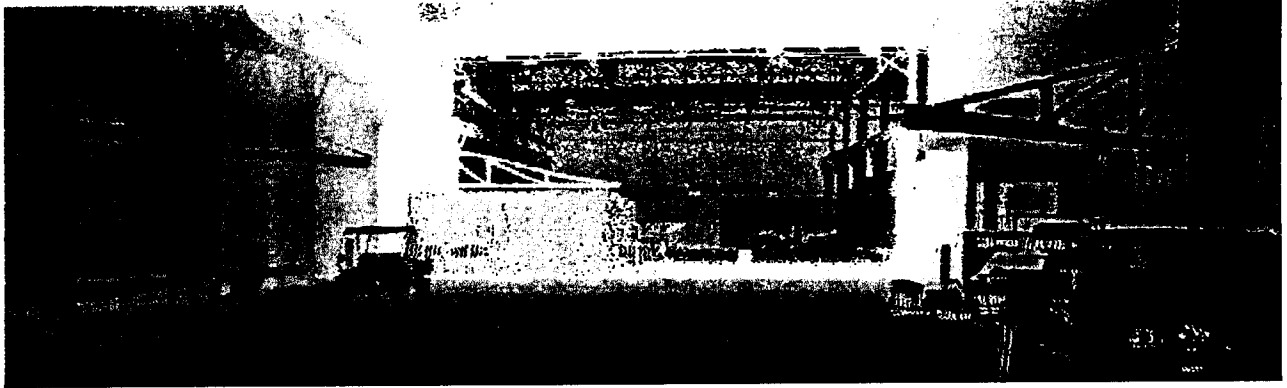

Range, different offset

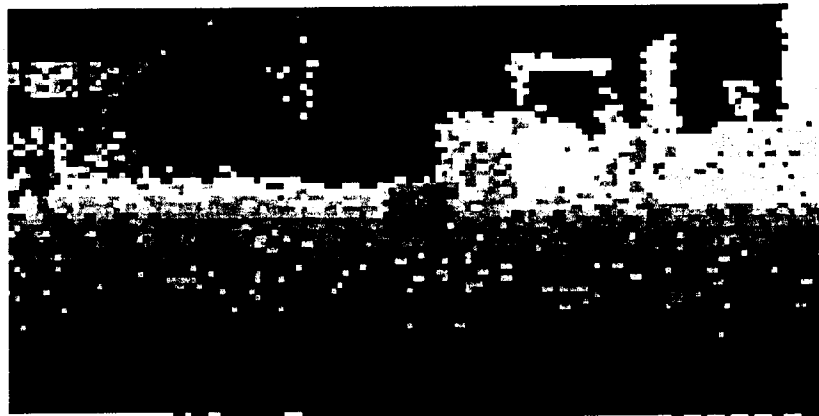

Reflectance

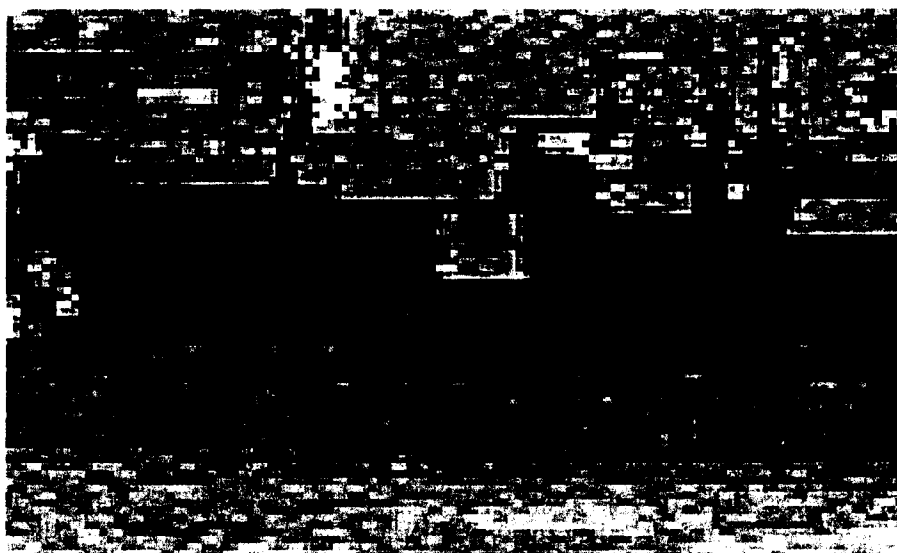
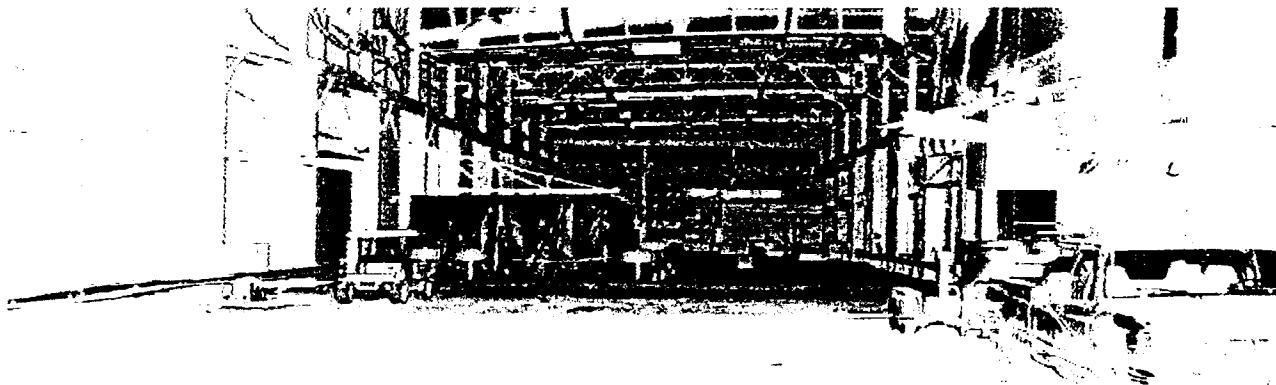

Time Evolution of Single-Line Reflectance Scans

(Inverted for better printing)

$t=0$

$t=t_1$

$t=t_2$

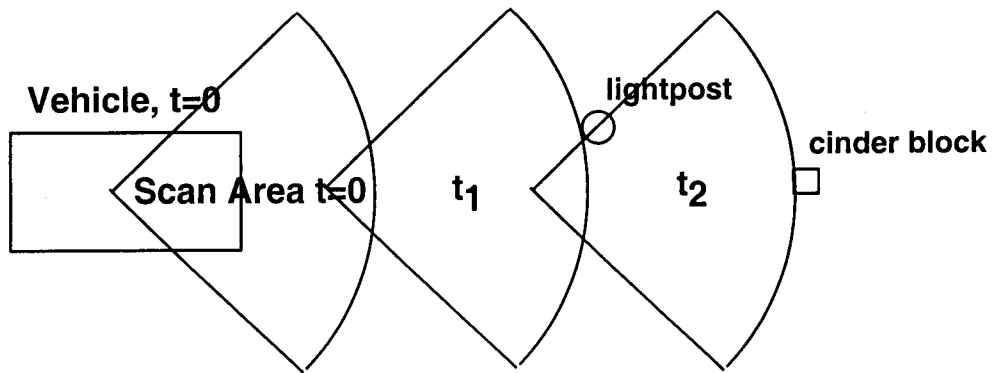
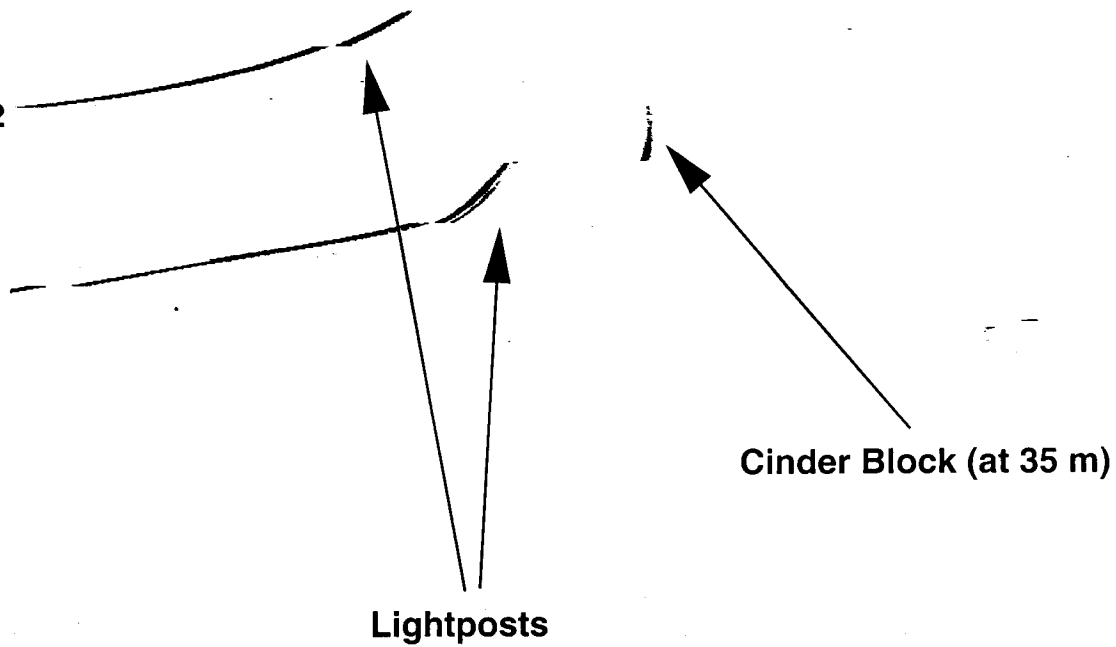

X Graph

$Y \times 10^3$

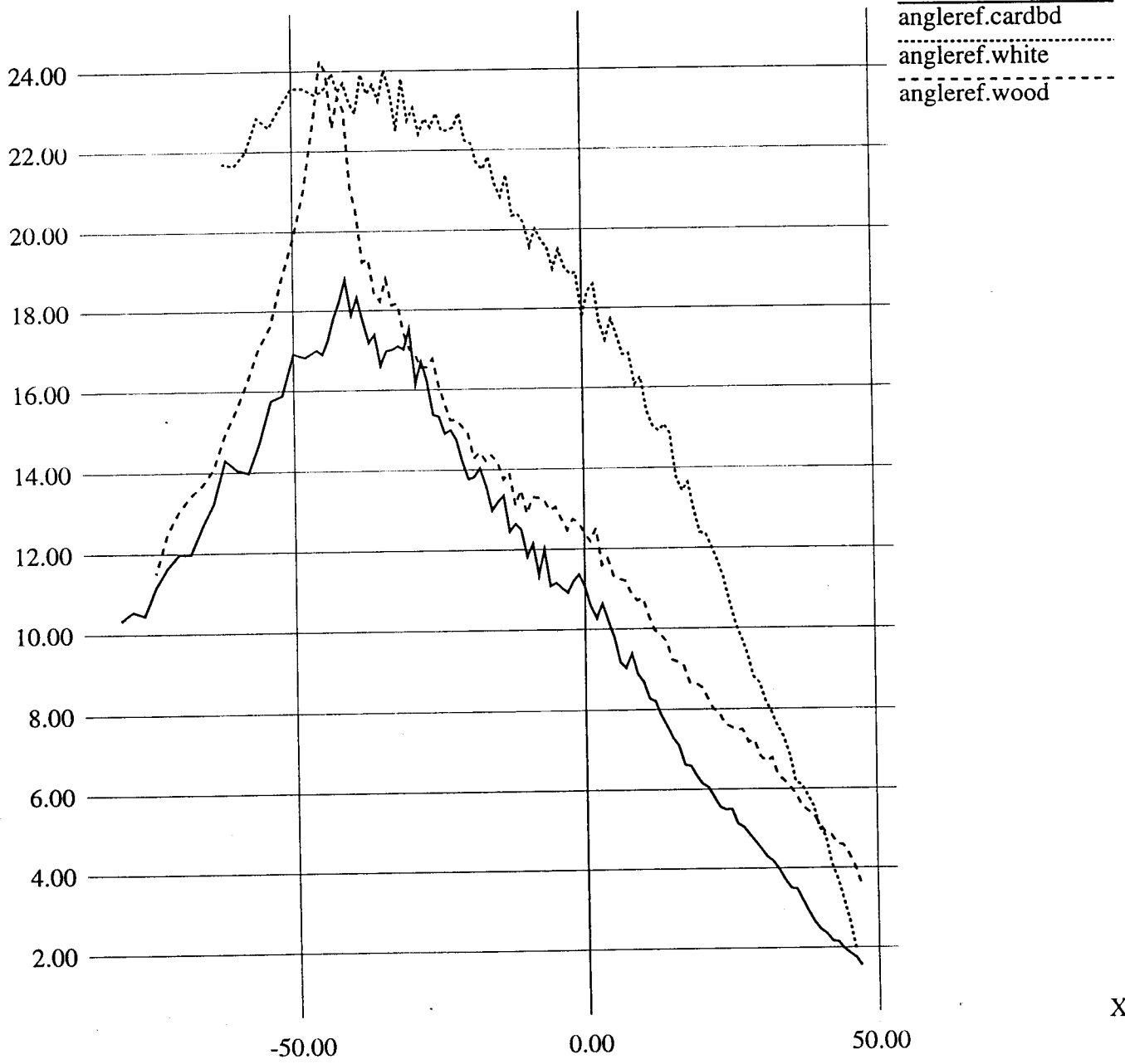

X

Last Pulse Detection

- OPTTECH
- RLEGL
- Z+F

Laser/
Receiver

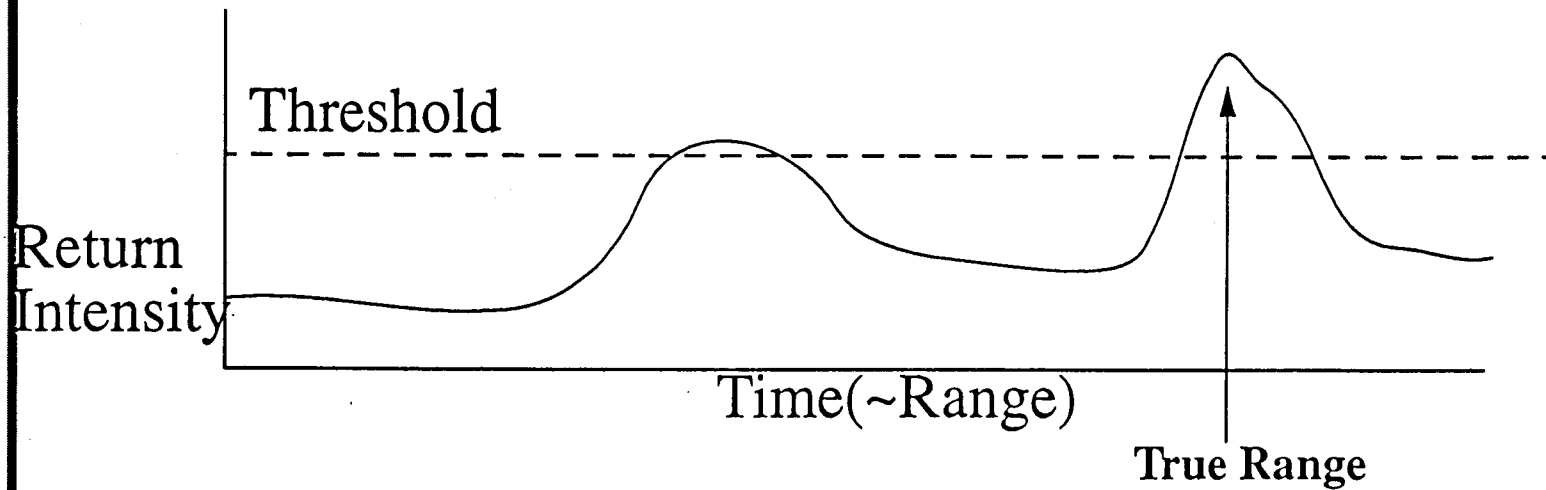
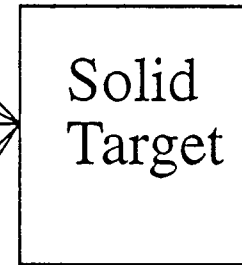
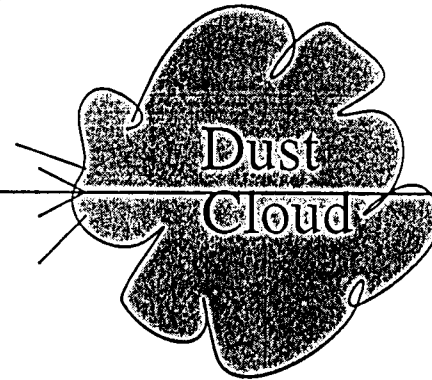

Backscatter RCS at 94 GHz

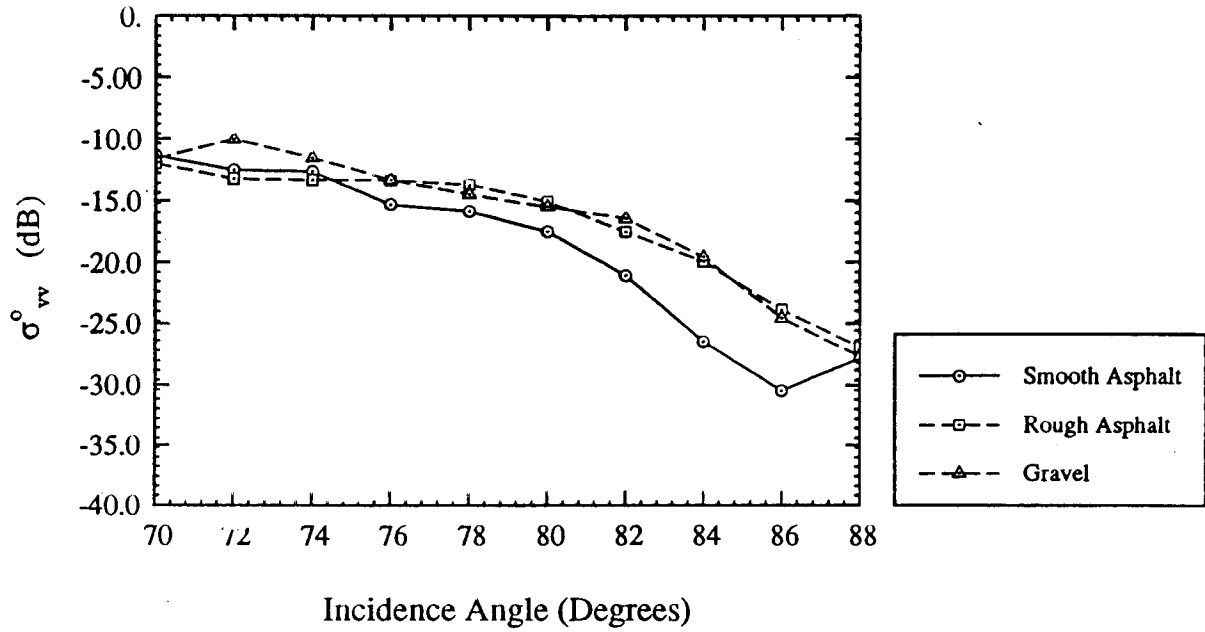

Backscatter RCS at 94 GHz

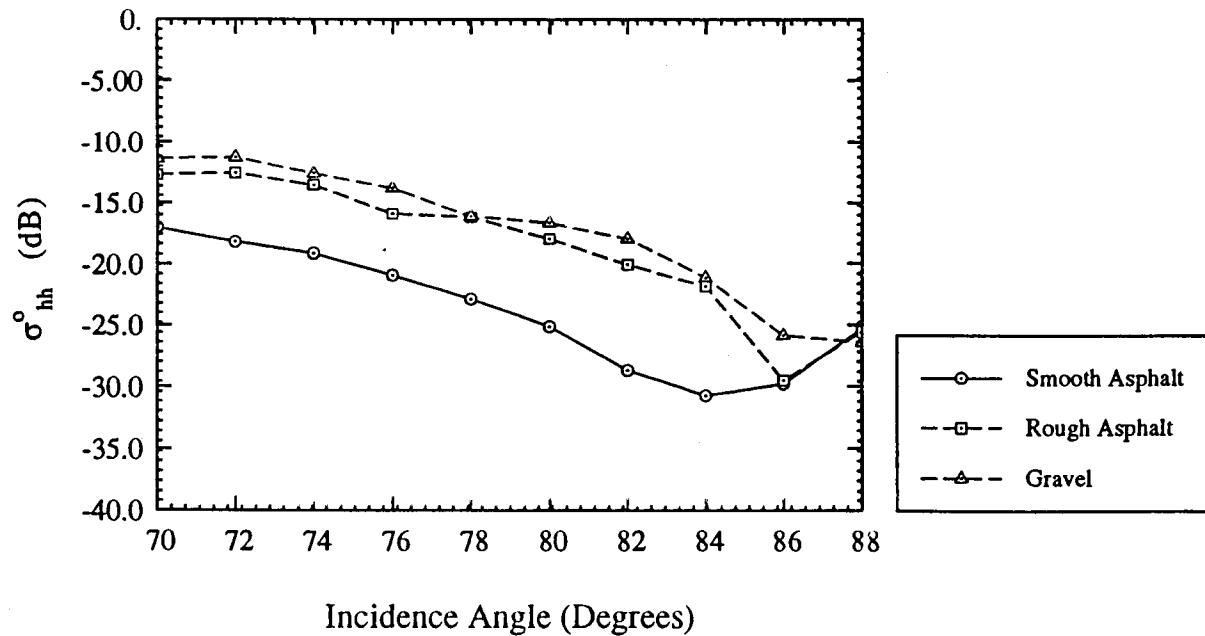

Asphalt Backscatter RCS at 94 GHz

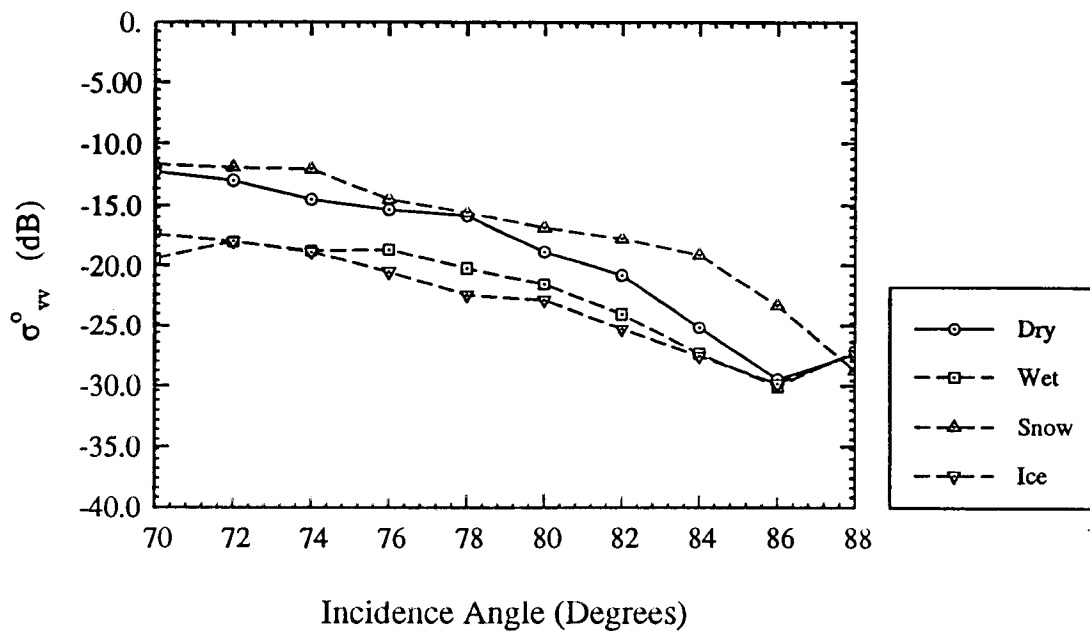

Asphalt Backscatter RCS at 94 GHz

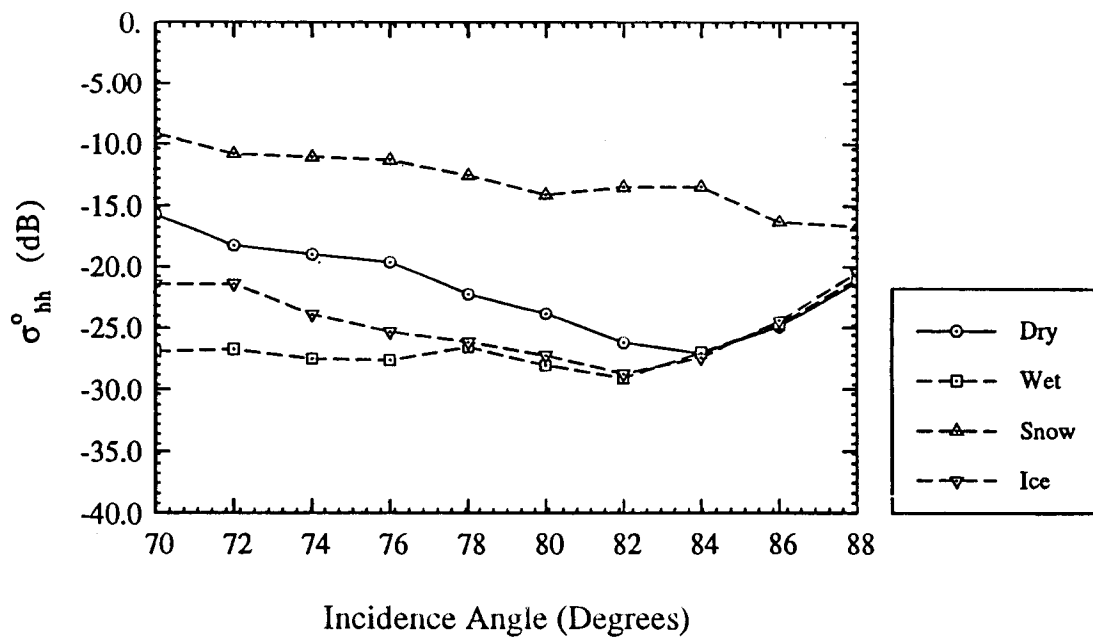

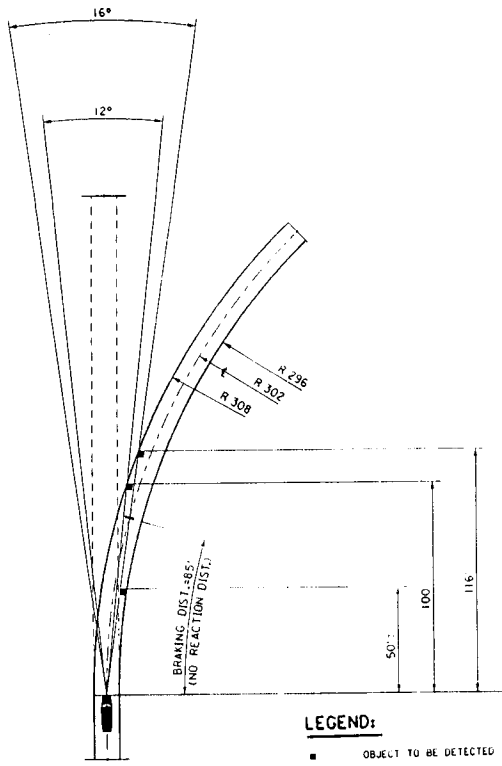

MIN RADIUS
 @ 30 MPH

LEGEND:

- OBJECT TO BE DETECTED
- TRAVEL LANE

FIGURE 1

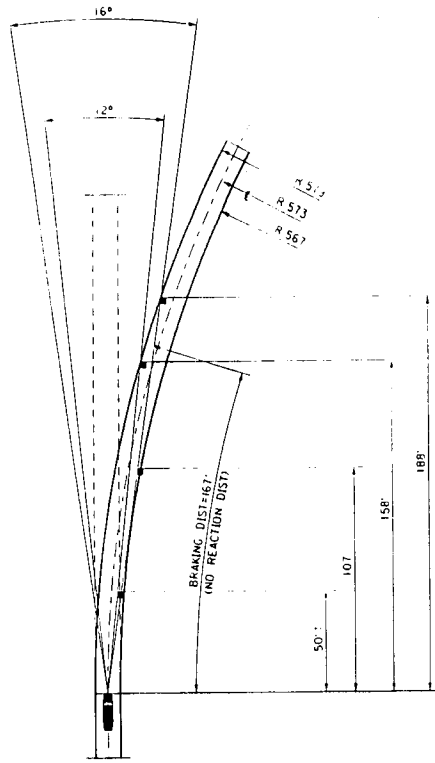

MIN RADIUS
 @ 40 MPH

FIGURE 2

**OBJECT DETECTION
 ON SMALL RADIUS CURVES**

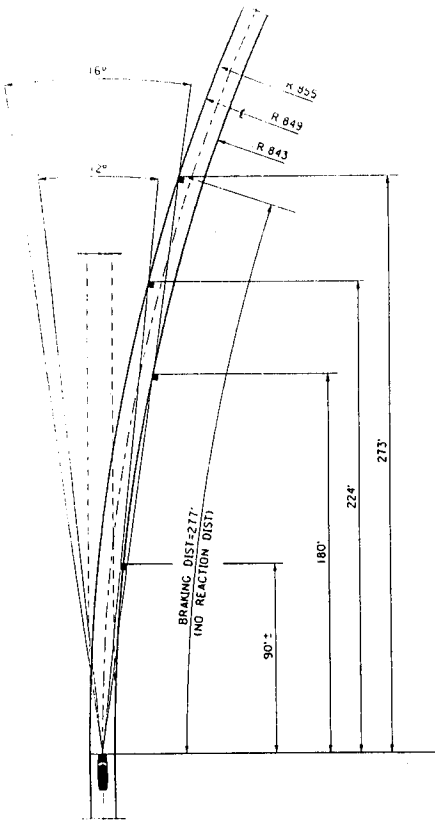

MIN RADIUS
 @ 50 MPH

FIGURE 3

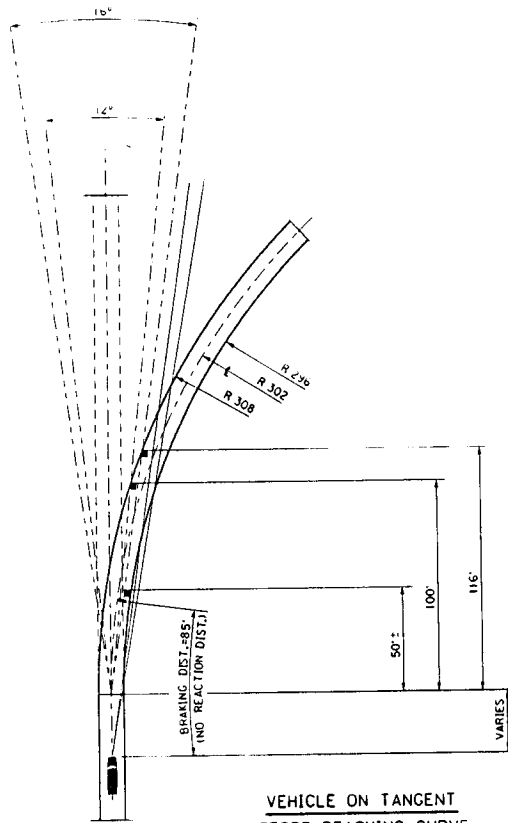

VEHICLE ON TANGENT
 BEFORE REACHING CURVE

FIGURE 4

Comments:

- Perhaps the most difficult problem
- Many of the technologies have some promise; none are proven
- Do not yet have a complete problem scope
- Do not yet have a clear consensus on cost / effectiveness of fencing and barriers
- Do not yet have any conclusions on infrastructure-based sensing and system design

Recommendations 2:

- Continue problem definition work, including specialization for IVI
- Initiate some work on infrastructure-based sensing
- Continue stereo, ladar, polarimetric radar
- Continue sensor fusion
- See recommendations on Sensor Friendly Roadway

Problem 3: Where in the Lane Are We?

- Subproblems:
 - automated lateral control
 - snow plow guidance
 - run-off-road warning
 - lateral control stability assist
 - road position prediction
- Possible Solutions:
 - On-Vehicle Sensing - Vehicle Lateral Position

NAHSC Activities:

- PATH Magnetic Markers
- PATH / 3M Magnetic tape
- OSU FSS
- CMU RALPH
- CMU Radar retroreflectors
- CMU Carrier-phase GPS

Site #1: Magnetic field measured along Z axis

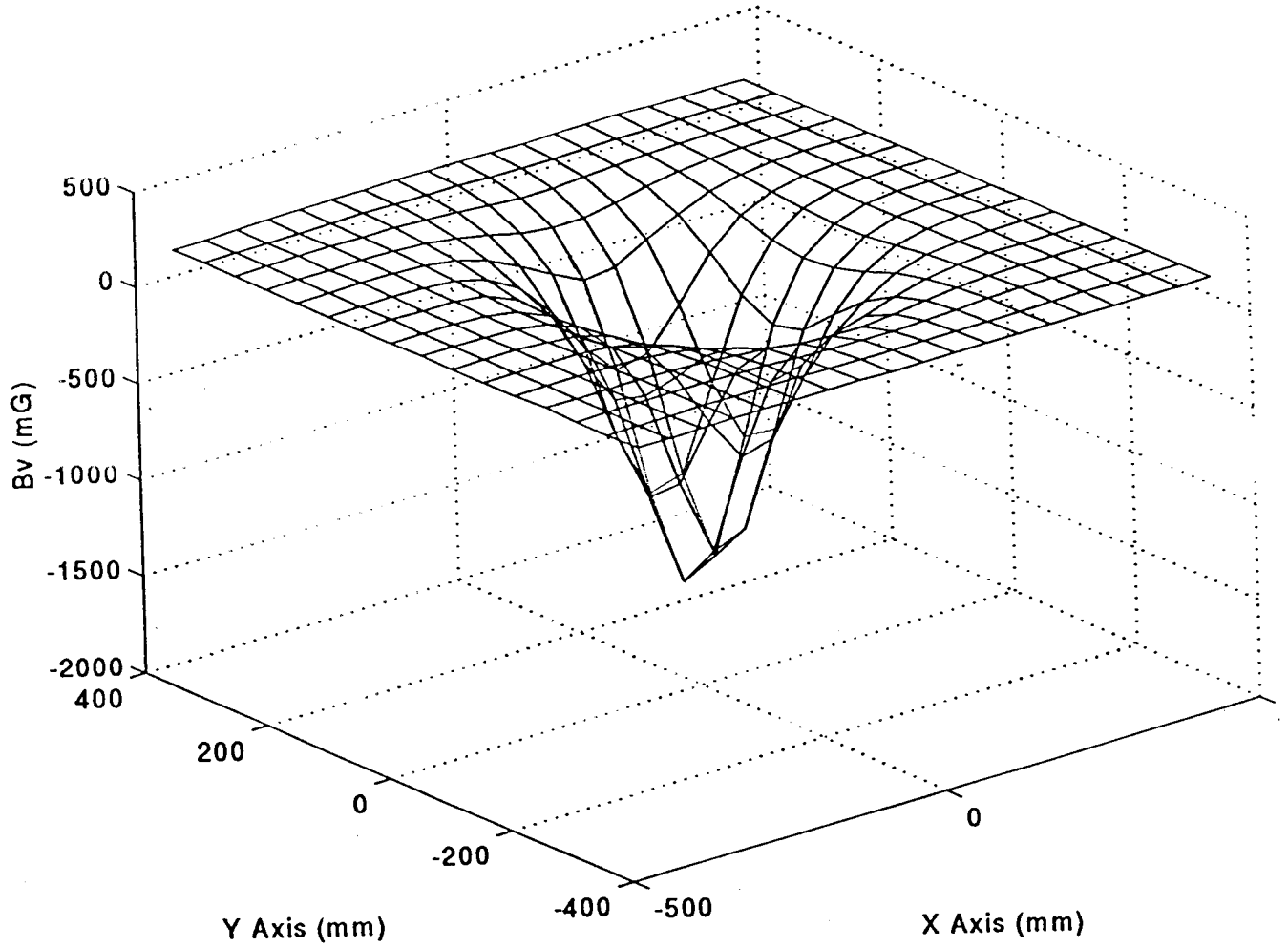

Site #1: Re-Bar distortion along Z axis

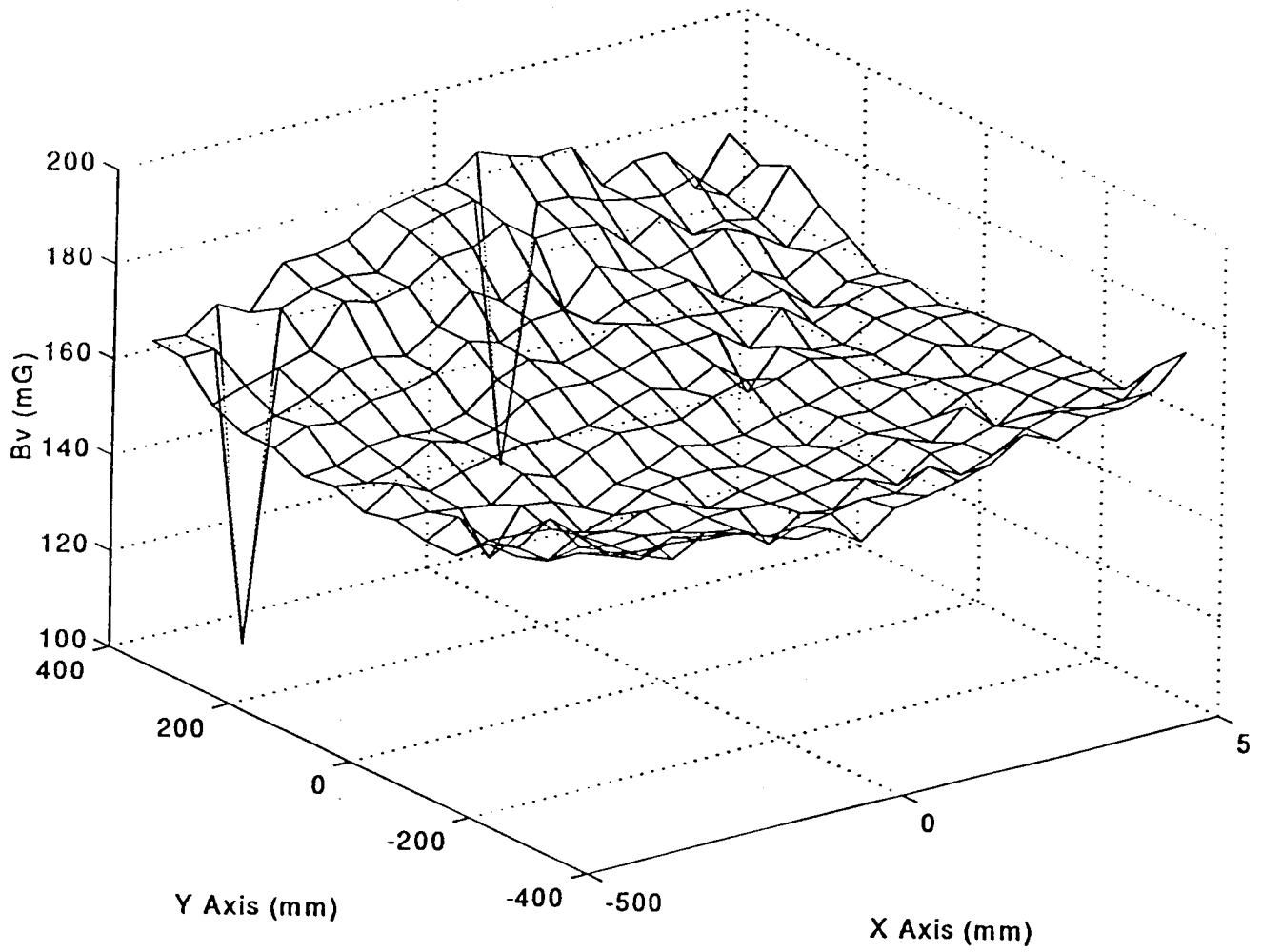

Site #1: Magnetic field measured along X axis

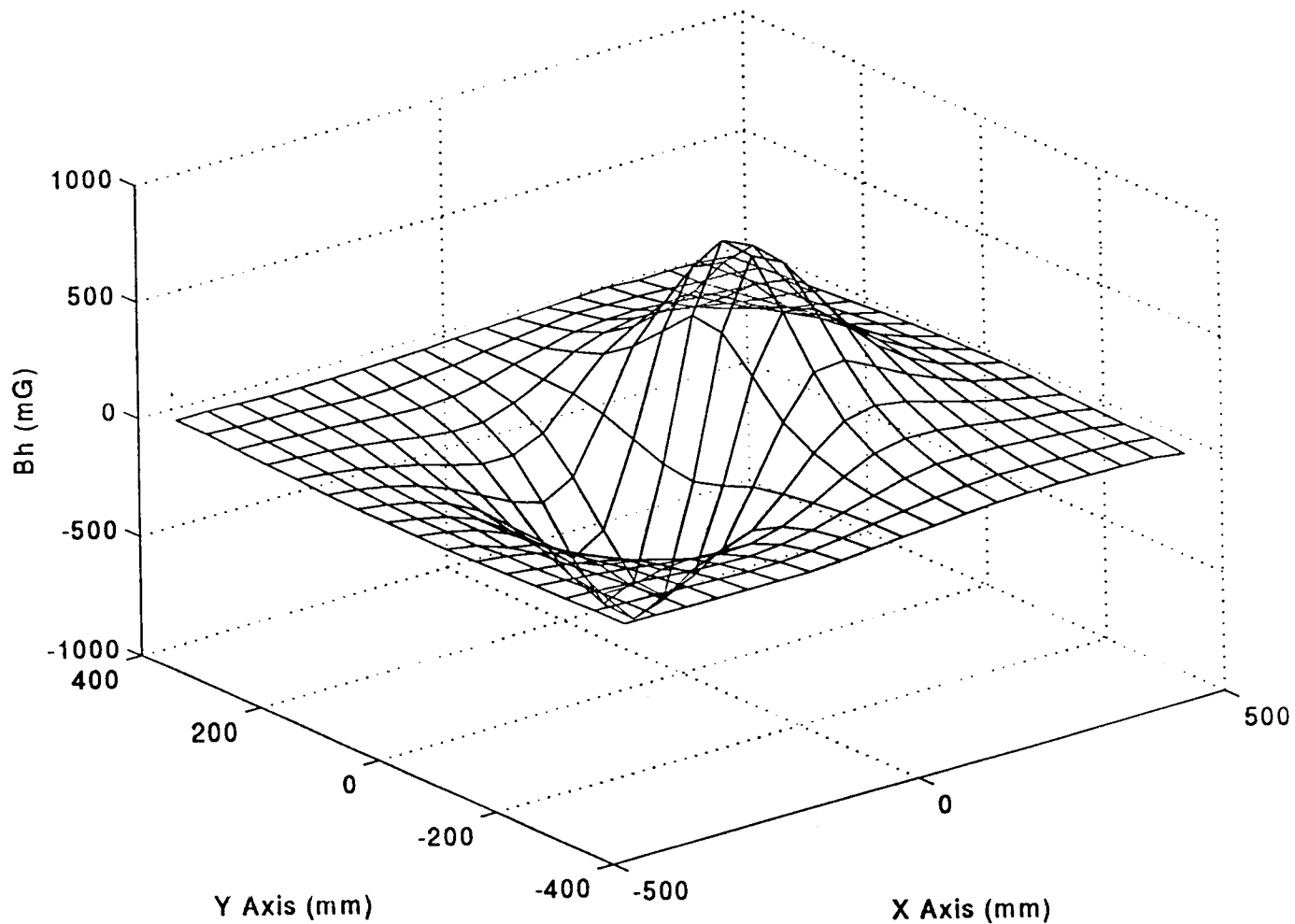

Site #1: Re-Bar distortion along X axis

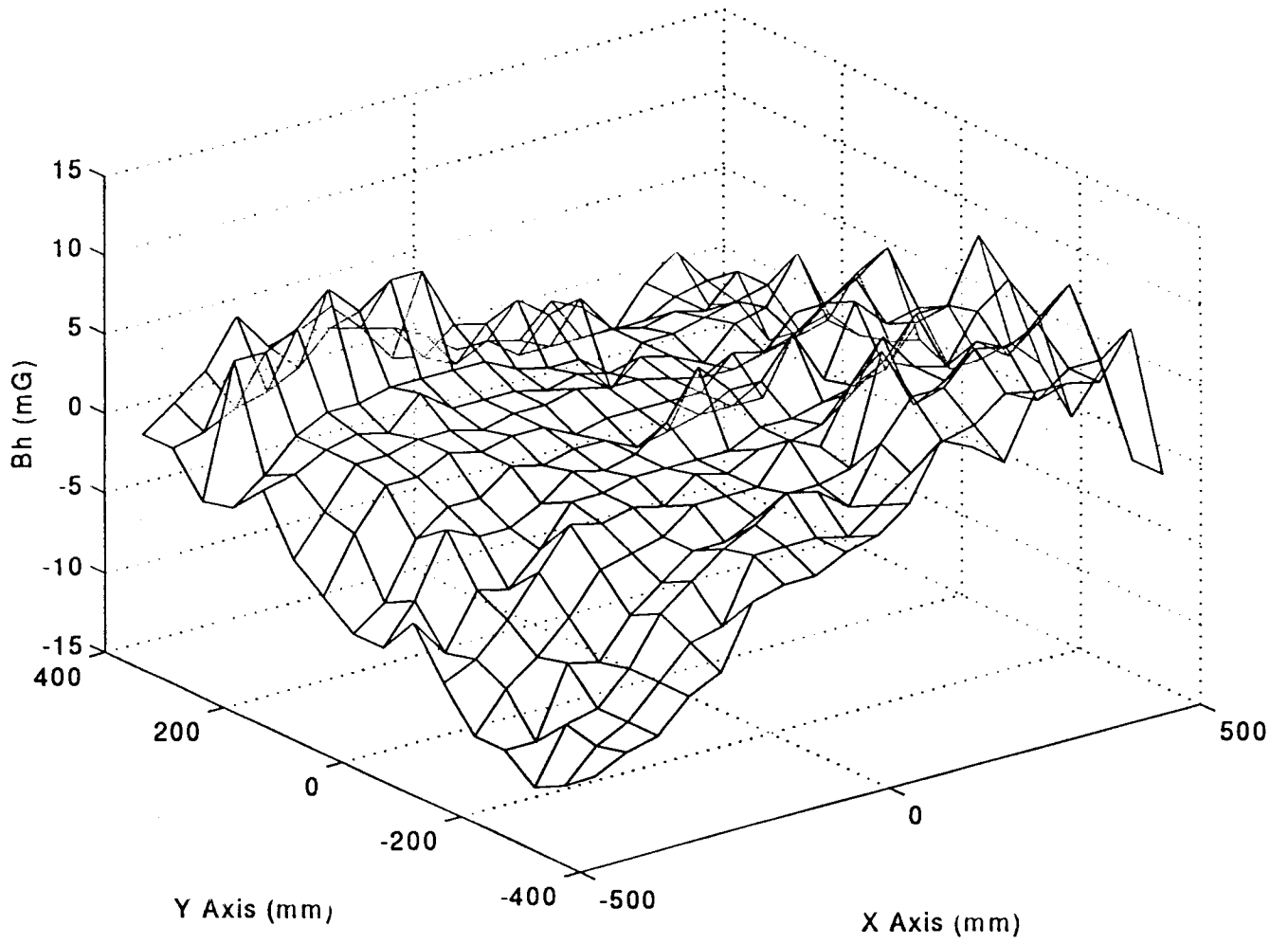

Radar-Reflective Highway Marking Tape for Vehicle Guidance

- **Modified lane marking tape permits collision-avoidance radars to sense lateral position**
- **Concept successfully demonstrated by OSU at NAHSC 97 Demo in San Diego**
 - 11 GHz radar
 - lane-centered tape
- **Further development required for**
 - operation in newly-allocated 77 GHz band
 - tape location at lane boundary

Stripe Operation and Design

- **Backscattered signal is a grating lobe in the desired direction (a frequency selective surface)**
- **Radar senses slot spacing (can encode motorist info)**
- **Roadbed material affects azimuth pattern but not grating lobe angle**
- **11 GHz tape based on standard lane marking tape from 3M Corp.**
 - Three-layer construction: adhesive, metal foil, top colored coating
 - Foil layer punched with periodic slot pattern

Stripe Concept

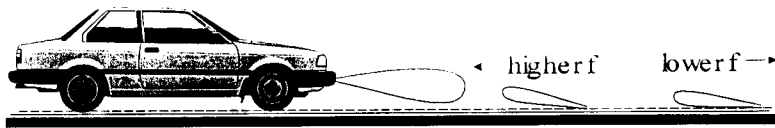

(a)

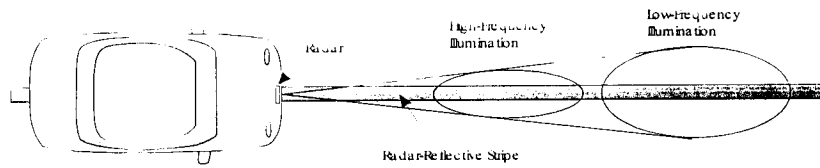

(b)

Installs With Standard Equipment

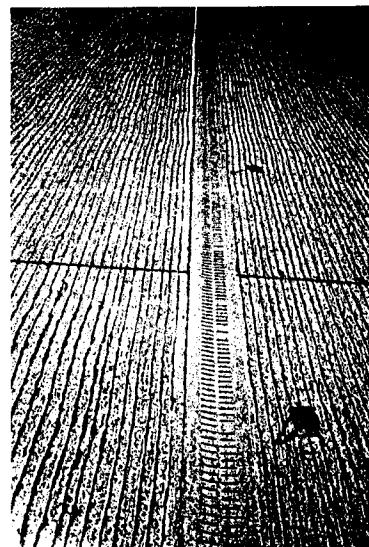
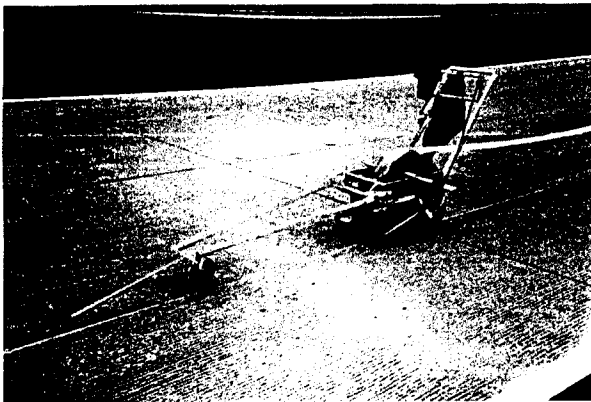

Azimuth Response

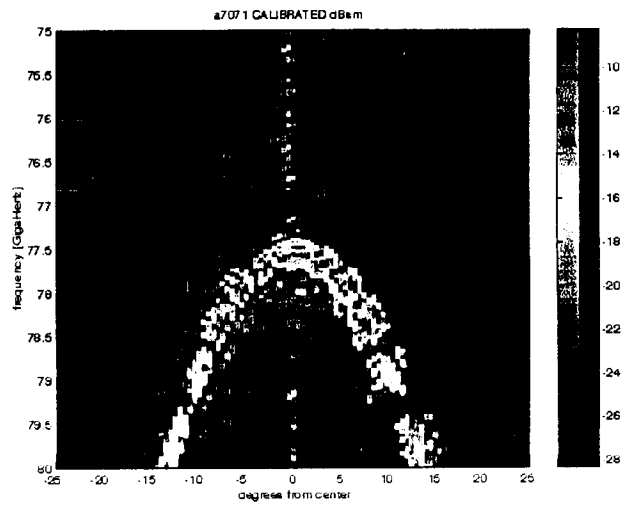

Elevation Response

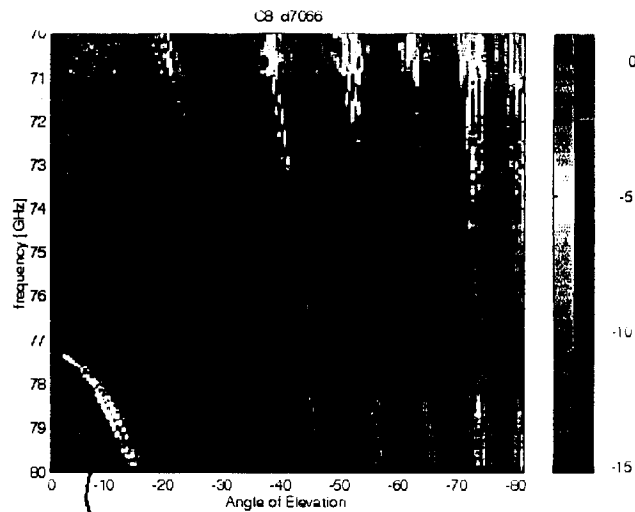

Operational Return

Degaroute® safety markings

Safety markings (profiled markings, Type-II markings) feature different elevations. These elevations will not be completely covered by a water film during rainfall and therefore produce improved night-time visibility compared to standard markings. Additionally, the noise that is produced when traffic crosses over presents a warning effect.

Degaroute® cold plastic is particularly suitable for producing profiled markings since they will not be deformed even in high temperatures when traffic crosses over.

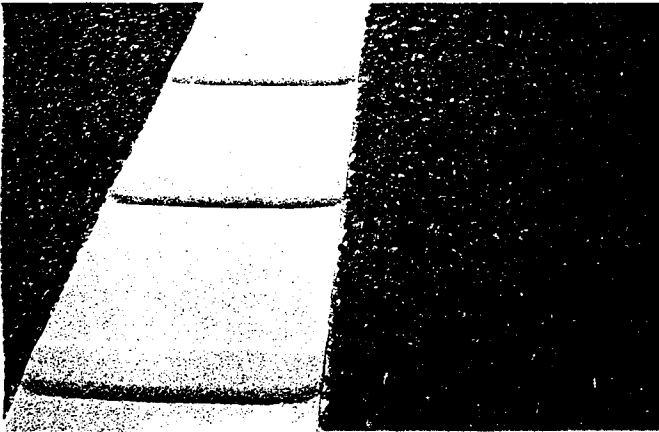

Degussa-system

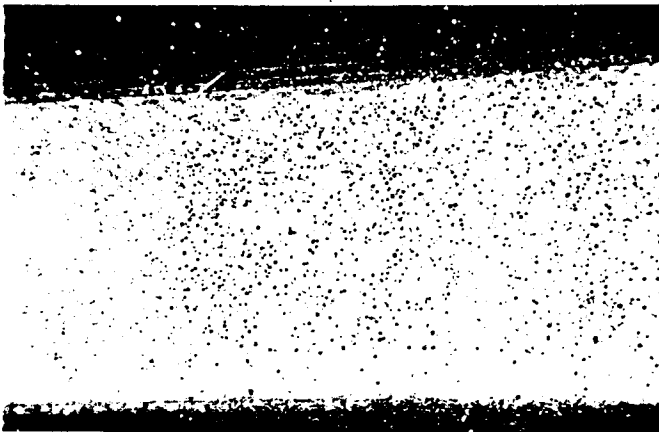

Reflex-system
(Hitzblech company)

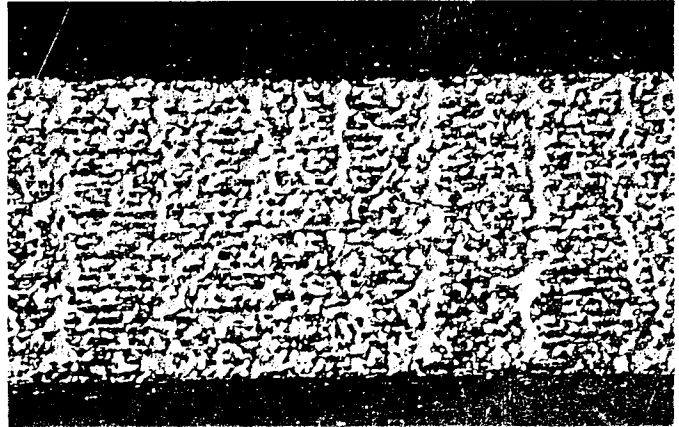

Structure-system
(Wyssbrod company)

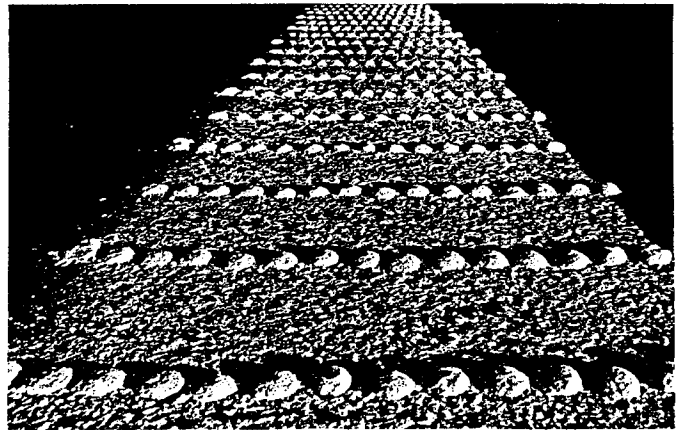

Spottflex-system
(Superfos company)

REFERENCE ROAD STRETCHES
Kantonstrasse Boningen - Aarburg



Structure marking 2 kg/m²
Application: autumn 1992



■ Structural Markings

The 3 Major Advantages of Structural Markings

Picture left: excellent night visibility of structural and profile marking in the rain.

Picture right: profile marking on and bend. Picture below: macro photograph of structural marking.

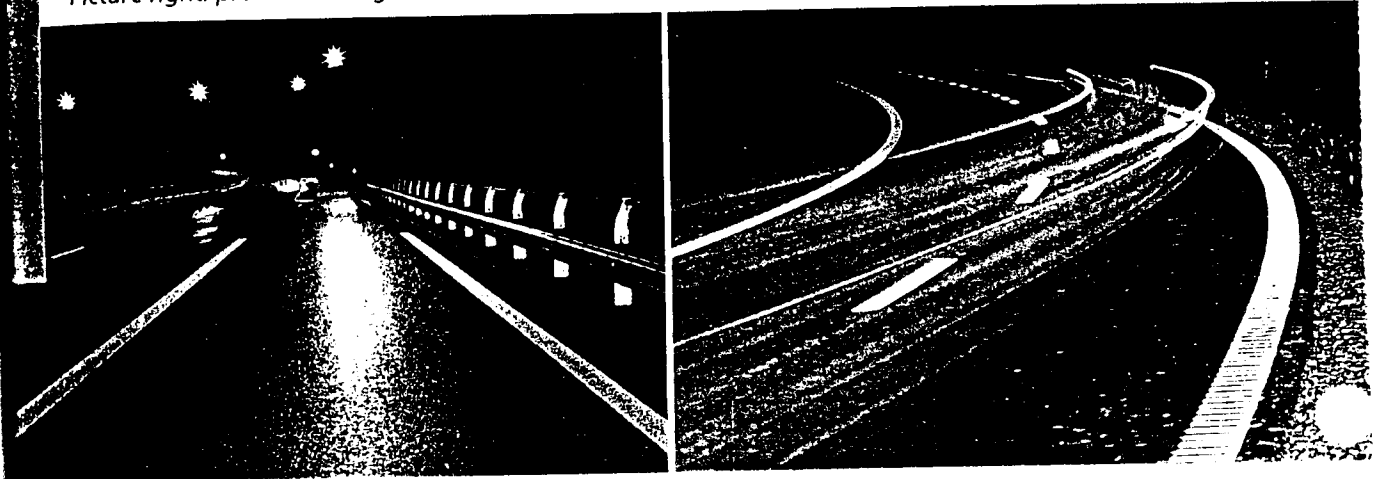

Excellent Night Visibility when Wet

Structural markings stand out from water film on a rain-wet road, glass beads in the marking material reflect headlight beams.

The well-known significant advantage with flat markings is that the dark the light from headlights is reflected away like from a flat mirror, the glass beads underneath reflect the light.

Centre lines, roadside markings, orange guiding lines incomparably more visible at night when wet when made with the new structural marking.

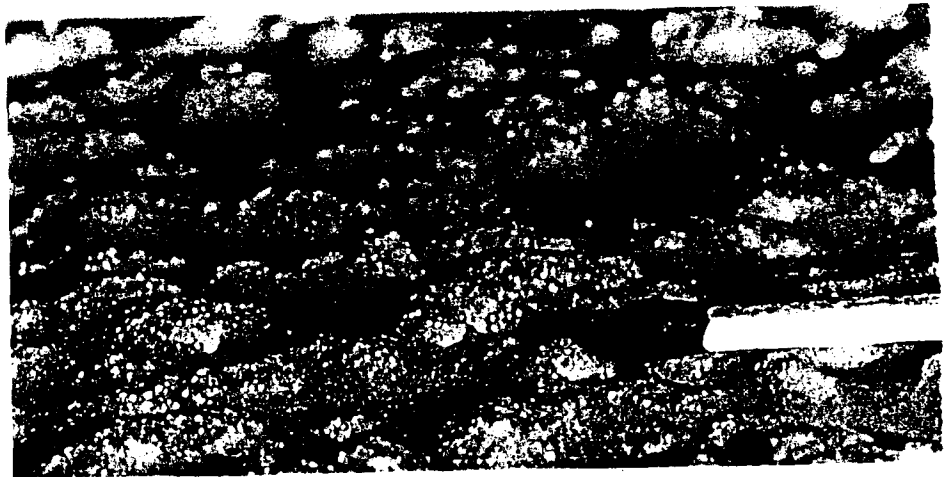

■ Durable Night Visibility with Years of Service

Tests show that, thanks to their 3-dimensionality, even heavily trafficked structural markings maintain their good reflective properties for years. The structural raising protects the reflecting material.

■ Good and Durable Skid Resistance

There is no skid danger in the wet – in fact the opposite to flat markings: these show high SRT values when new but as the quartz content wears, the grip properties are soon lost.

No water film forms on top of structural marking, there is therefore no skid danger and no hydroplaning.

Even after the heavy snow of the winter of 1990/91, there was no significant

Comments:

- All solutions have sensors on vehicle, sensing features in infrastructure
- Preview can come from sensing or maps
- Decisions are really cost-benefits:
 - installation and maintenance
 - security
 - on-vehicle vs. infrastructure cost
- We don't have the data to really know either costs or benefits

Recommendations 3:

- Continue at least magnetic sensing, vision sensing, FSS
- Think systems
- Think cost-benefit

Problem 4: Vehicle Control

- Subproblems:
 - Lateral control, longitudinal control
 - Integrated lateral and longitudinal
 - Emergency maneuvers
 - Special maneuvers, e.g. merge
- Possible Solutions
 - Algorithms - Integrated Control
- NAHSC Activities
 - 5-prong PATH approach

Task Objectives

Task 1 Control Integration and Validation

To integrate the current control algorithms for longitudinal and lateral control, to update vehicle model and to conduct experiments

Task 2 Robust Tractive Force Model

To improve robustness of control algorithms through tractive force control with experimental verification

Task 3 Real-Time Estimation of Road/Tire Characteristics and Adaptive Control

To use integrated vehicle model and design controller with capability to update tire model in real time to account for changing road/tire interactions

Task 4 Transition Maneuvers

To study lane change, platoon join and split, entry and exit maneuvers and the transition between maneuvers with experiments

Task 5 Alternative Sensing Systems for Safety and Robust Enhancements

To integrate vision and magnetic sensing systems, and to evaluate auxiliary sensing schemes

Task 1: Combined lateral, longitudinal control

Hung Anh Pham

- **Project description**

To improve performance and robustness by stressing a holistic approach towards vehicle modeling, referencing, and control synthesis.

- i)* Compile 21-state vehicle model describing sprung mass, engine, transmission, drive train and actuator dynamics.
- ii)* Explicitly account for sprung mass kinematic and tire force couplings in control design.
- iii)* Numerical and experimental validation of modeling and control methods.
- iv)* Combine magnetic and radar referencing to enhance controller transient performance, provide string stability, and provide sensing redundancy.

- **Accomplishments to date**

- i)* Coded *FORTRAN* and *C* simulation packages and made available for release.
- ii)* Compared performance of coupled Sliding Controller to decoupled designs, which includes linear quadratic optimal and nonlinear robust controllers.
- iii)* Conducted experimental validation studies at PATH's RFS and GGF test facilities using Pontiac test vehicle.

- **Accomplishments (cont'd)**

iv) Demonstrated, via analysis and simulation, the potential benefits and practicality of the hybrid vehicle-following, point-following...

vehicle-following, point-following control

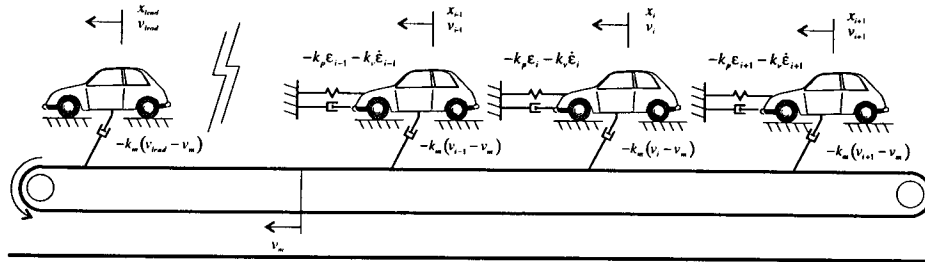

By slaving each vehicle to a moving belt (of magnetic markers), as well as to its immediate predecessor, it is possible to achieve the string stability benefit of lead vehicle referencing - without extensive intervehicle communications.

...and hybrid lane-keeping, heading angle control strategies.

Lane-keeping, heading angle control

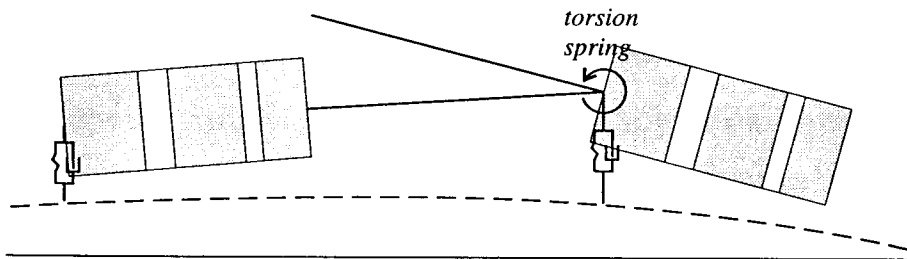

The use of radar azimuthal angle reading allows lookahead capability, which can be used to increase vehicle yaw damping. At the same time, magnetic marker referencing provides absolute lateral string stability.

Task 2: Robust Tractive Force Control

Hyeongcheol Lee

Project Description

- Control of the tractive forces to achieve robust vehicle maneuvers in the longitudinal and lateral direction under varying and adverse driving conditions
- Estimation of the wheel slip ratio and the slip angle
- Verification by simulation and experiment

Results to Date

- Velocity estimation algorithm has been developed by using sensor fusion in a Kalman filter based framework.
(Sensor fusion is necessary to enhance estimation quality and to prepare for sensor failure situation.)
- A control algorithm for coordinated control of longitudinal and lateral tractive forces has been developed using input/output linearization and adaptive backstepping technique.

Examples of results

1. Longitudinal velocity is estimated by sensor fusion in an adaptive fuzzy Kalman filter based framework. Noise covariances are used as the reliability index of each sensor (accelerometer and tachometer).

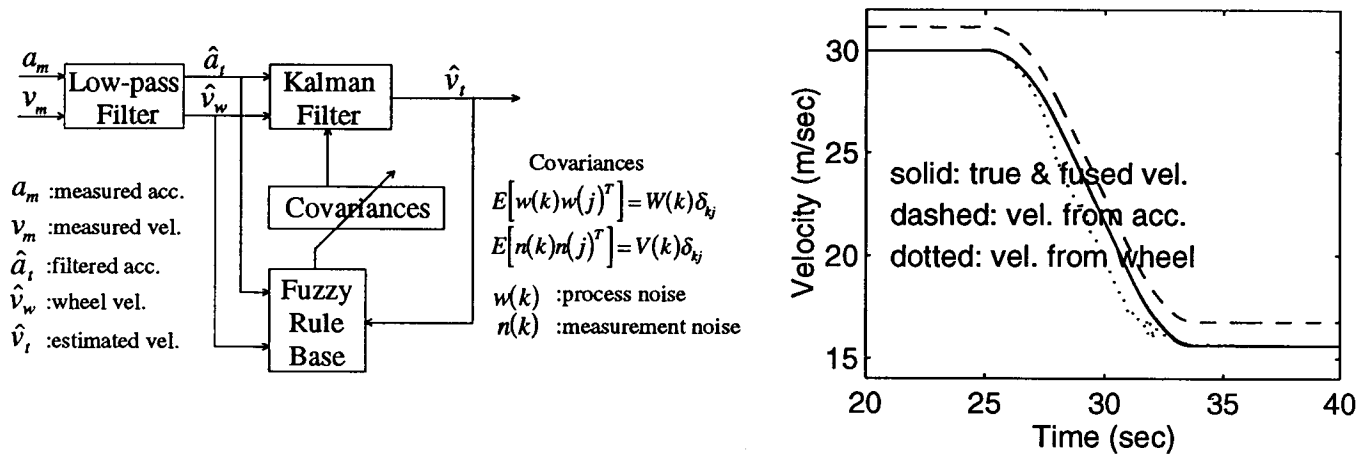

2. Tractive Force Control using input/output linearization and adaptive backstepping technique is designed for combined maneuvers of longitudinal platoon and lateral lane following control. Each error (longitudinal, lateral and yaw) goes to zero while wheel slips are maintained in stable range in adverse driving condition. (RWD and 4WS vehicle, slippery road condition)

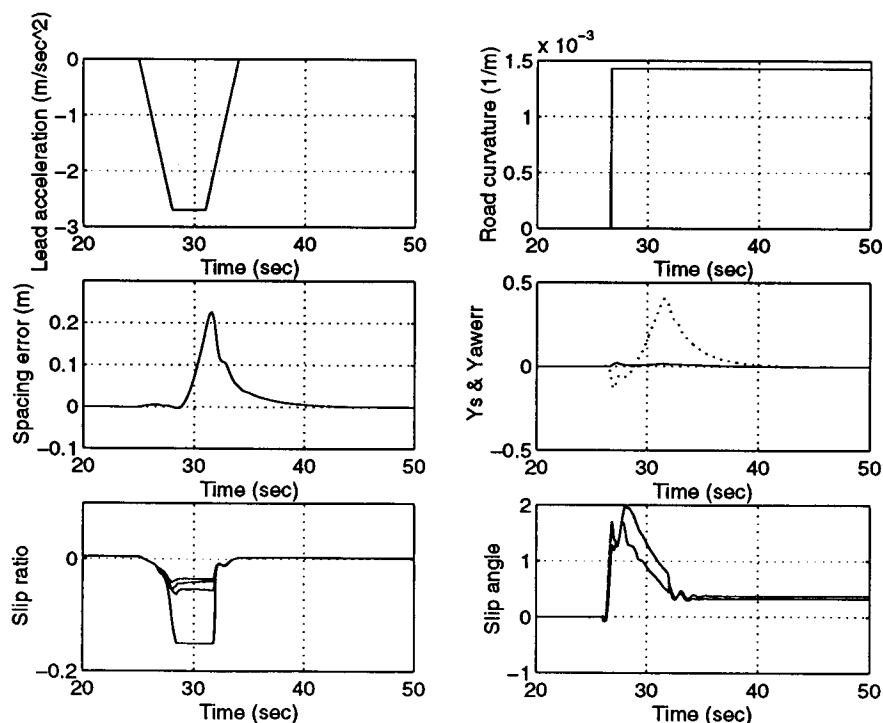

TASK 3. ROBUST LATERAL CONTROL OF PASSENGER VEHICLES

Sujit Saraf

PROJECT DESCRIPTION

- The controller must be robust to road-tire variations, such as rain, ice, worn-out tires, and must be stable in emergencies.
- Estimation of variables must be independent of vehicle parameters and road condition.
- Real-time estimation of road-tire characteristics and adaptive control must be studied.

RESULTS TO DATE

- Robust sliding mode controller implemented on a Pontiac 6000 test vehicle (Fig. 1).
- A robust slip angle estimation scheme, which is independent of vehicle mass, tire cornering stiffness or position of vehicle center of gravity, has been implemented.
- A non-parallel steering strategy has been developed to refine vehicle stability and maneuverability, with application in emergency maneuvers (Fig. 2).

EXPERIMENTAL RESULTS

Sliding Mode Controller

Road curvature (1/m) and lateral error (m) at vehicle nose during an experimental run at Richmond Field Station, using a sliding mode controller. Approximate vehicle velocity: 20 mph. Tracking error of vehicle nose stays within 5 cm of road centerline.

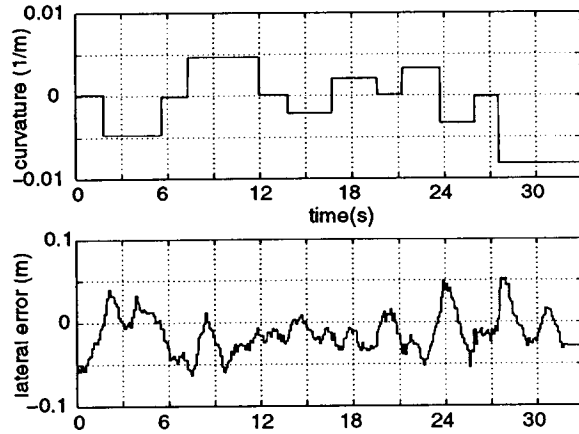

Fig. 1

Lateral Velocity Estimation

Measured and estimated values of lateral error, y_s (m), at vehicle nose during an experimental run at Richmond Field Station, using the lateral velocity observer. The second plot shows the estimated value of lateral error velocity, \dot{y}_s ($m s^{-1}$)

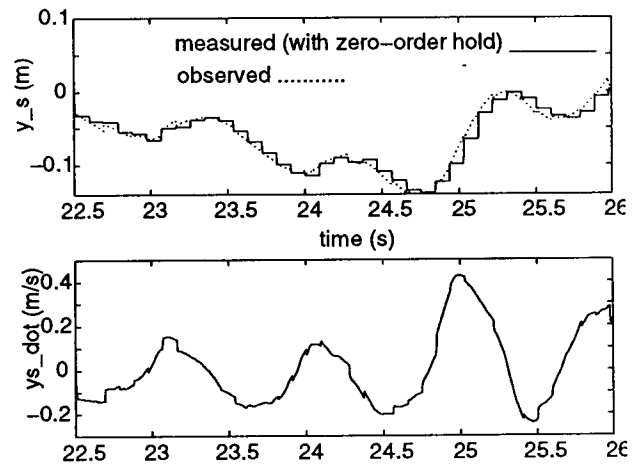

Fig. 2

Experimental Results

Road curvature (1/m) and lateral error (m) at vehicle nose during an experimental run at Richmond Field Station, using a sliding mode controller. Approximate vehicle velocity: 20 mph. Tracking error of vehicle nose stays within 5 cm of road centerline.

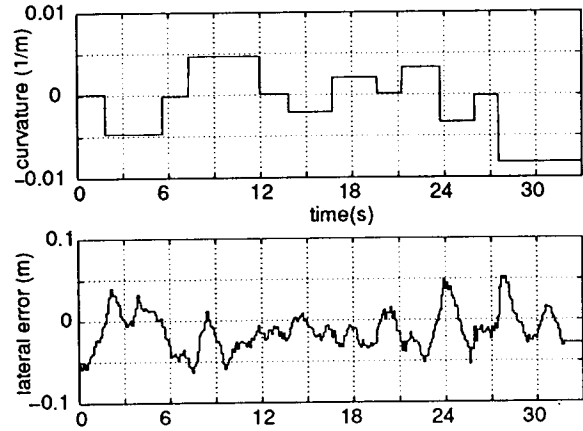

Fig. 1

Examples of Non-parallel Steering

Two non-parallel steering strategies which can be used to influence vehicle understeer characteristics, and therefore affect stability and maneuverability.

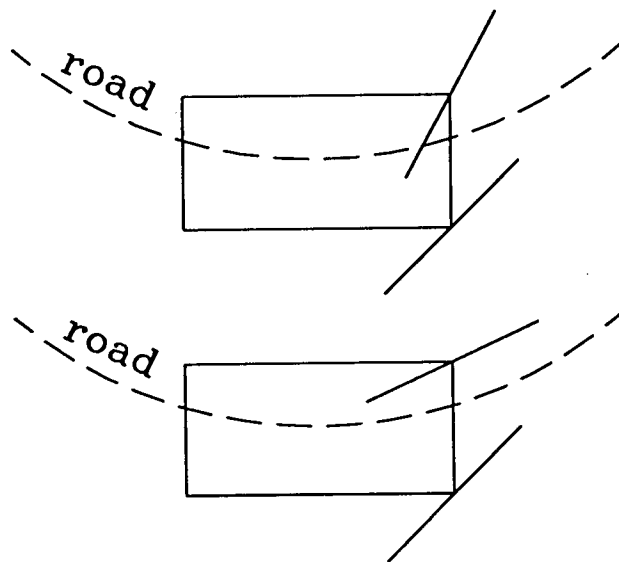

Fig. 2

An element of Task 4 : Entry Maneuver

Linh Thai

Project Description

To supply the automated lanes with vehicles from the manual lanes by employing procedures that aim to

- maximize passenger safety
- provide maximum passenger comfort
- increase traffic flow
- be robust to varying traffic conditions.

Results to date

To take advantage of past researches, entry maneuver is separated into two phases :

Phase I - entry vehicle matches traffic speed.

Phase II - lane change maneuver is performed.

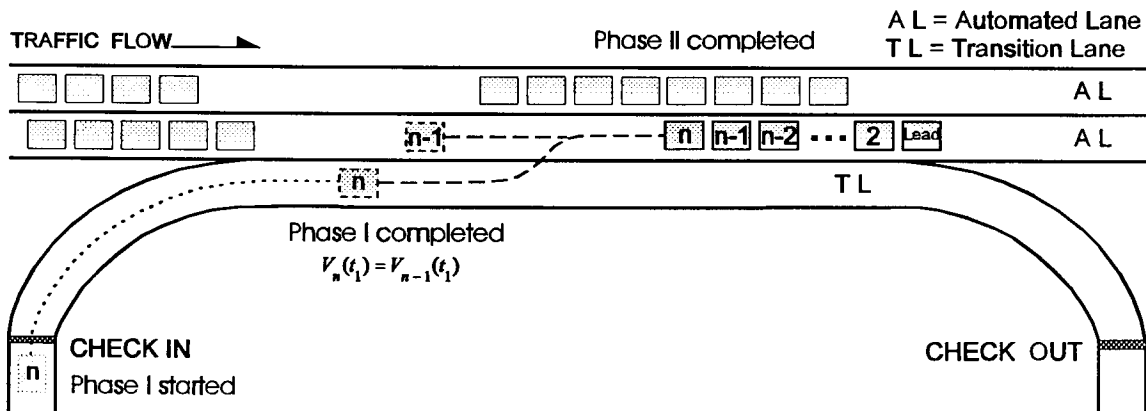

Trajectory and Controller for Phase I

- Simulation work is in progress.
- Trajectory profile :

$$\boxed{V_{n,des}(t) = V_{n-1}(t) - \sqrt{2a_{com}(D - \Delta X(t))}}$$

$V_{n,des}(t)$ = desired speed of the entry vehicle at time t.

$V_{n-1}(t)$ = speed of the $(n-1)^{th}$ vehicle at time t.

D, a_{com} = parameters selected based on comfort level.

$\Delta X(t) = X_{n-1}(t) - X_n(t)$, the difference in positions.

- Sliding-mode controller :

$$\boxed{\dot{S}(t) = -K * S(t)}$$

$S(t) = V_n(t) - V_{n,des}(t)$, sliding surface.

$V_n(t)$ = the speed of the entry vehicle at time t.

K = a varying controller gain.

Trajectory and Controller for Phase II

Lane change maneuver was studied by Wonshik Chee at the University of California, Berkeley. The results are being considered for phase II of the entry maneuver.

Task 4: Transition Maneuvers (Lane Change & Transition Between Control Modes)

Wonshik Chee

- **Project Description**

Develop a smooth transition between lane change and lane following maneuvers.

- **Results to Date**

- ◆ Designed a unified control system for both lane following and lane change maneuvers, and designed a tracking-error based transition method. (Figure 1)
- ◆ The new scheme is validated by simulations. (Figure 2)

Task 5: Alternate Referencing System

- **Project Description**

Develop a new sensing system to enhance safety and robustness.

- **Results to Date**

- ◆ Developed a new lateral position measurement scheme for discrete magnetic markers. (Figure 3)
- ◆ The new scheme is validated by experiments. (Figure 4)

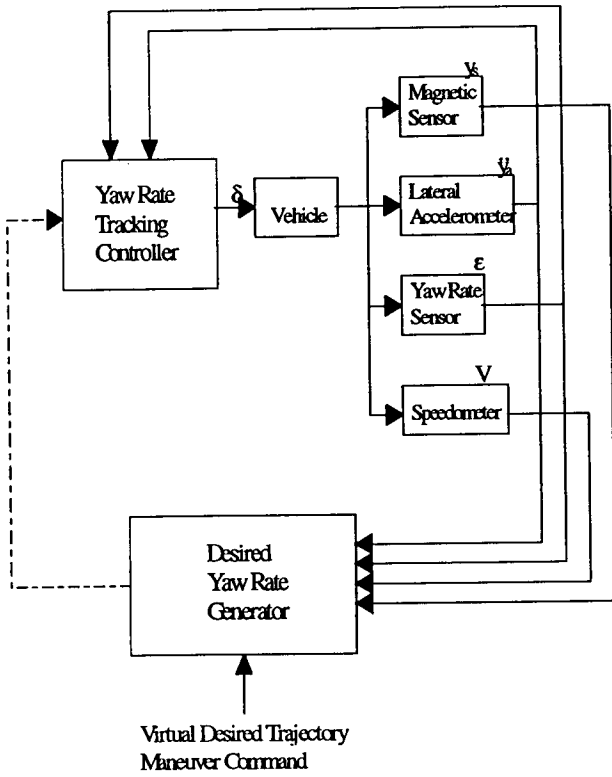

Figure 1: Structure of Unified Control System

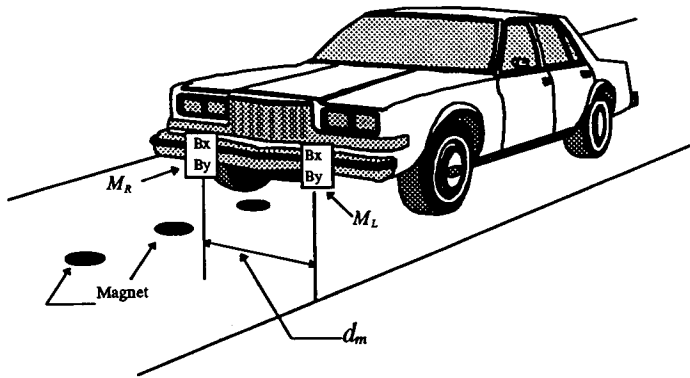

Figure 3: System Configuration of New Lateral Position Measurement Scheme

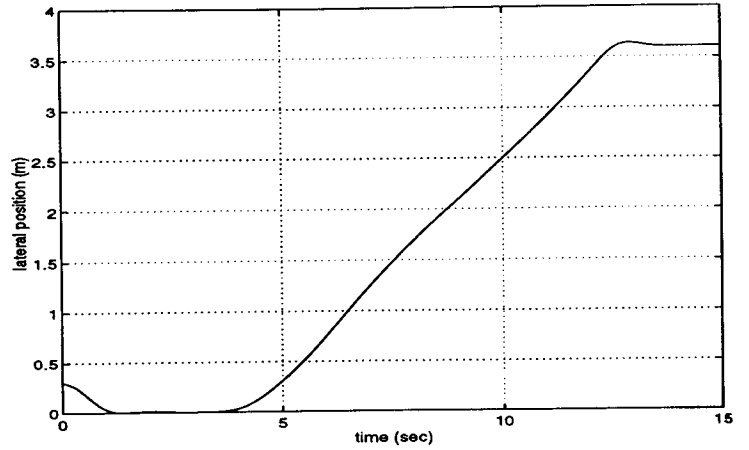

Figure 2: Simulation of Unified Control System

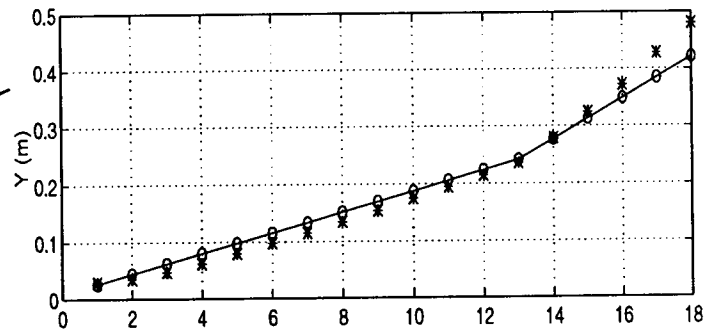
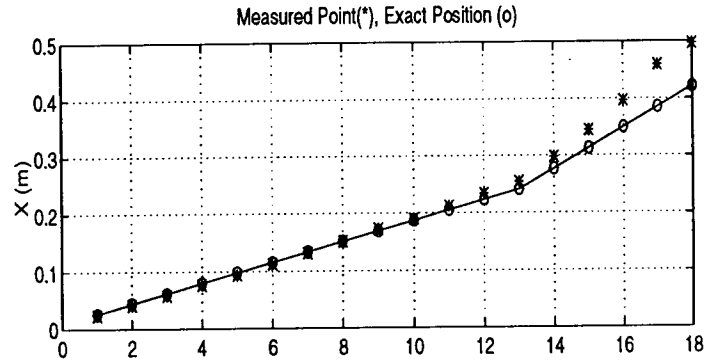

Figure 4: Experiments of New Lateral Position Measurement Scheme

Task 5: Alternate Referencing System

Graduate Student Researcher : Wonshik Chee

- **Project Description**

Develop a new sensing system to enhance safety and robustness.

- **Results to Date**

- ◆ Developed a new lateral position measurement scheme for discrete magnetic markers.
- ◆ Accuracy and reliability of the new scheme were validated by experiments.

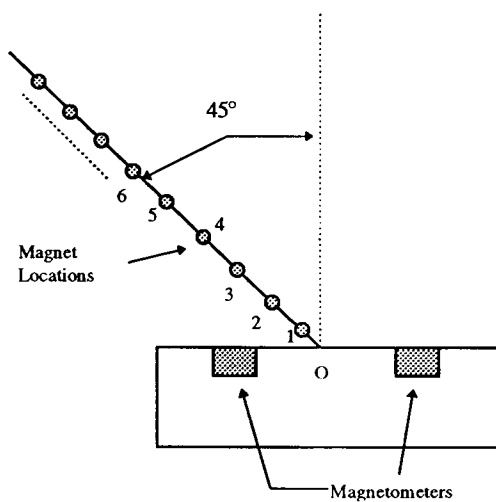

Configuration for Calibration Tests

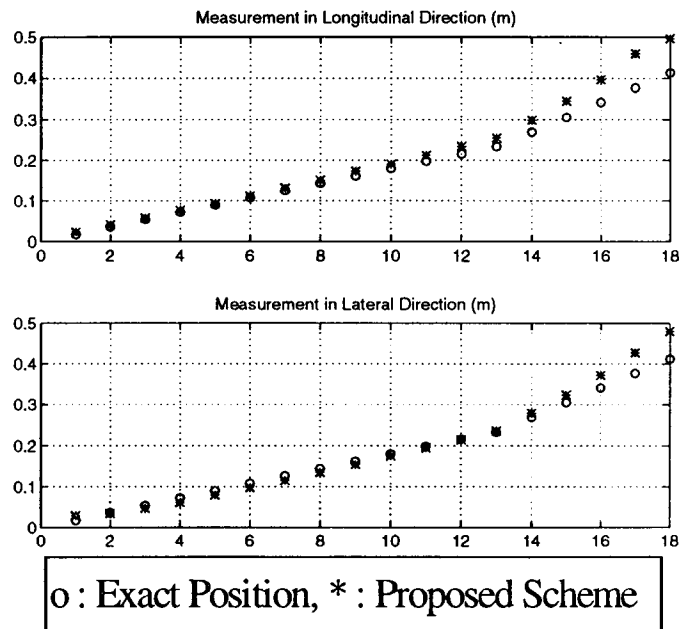

Lateral and Longitudinal Position Measurement

Error Norms of Position Measurement

Longitudinal Error (m)		Lateral Error (m)	
l_∞ norm	l_2 norm	l_∞ norm	l_2 norm
0.08315	0.03381	0.06744	0.02279

Lateral Position Measurement While Driving on Test Track at RFS

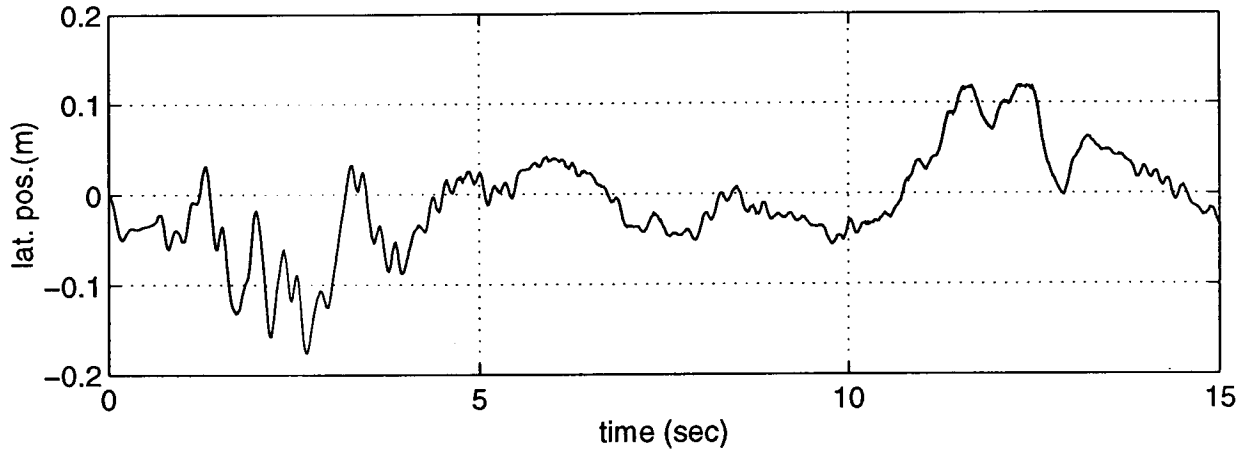

Test Track at RFS

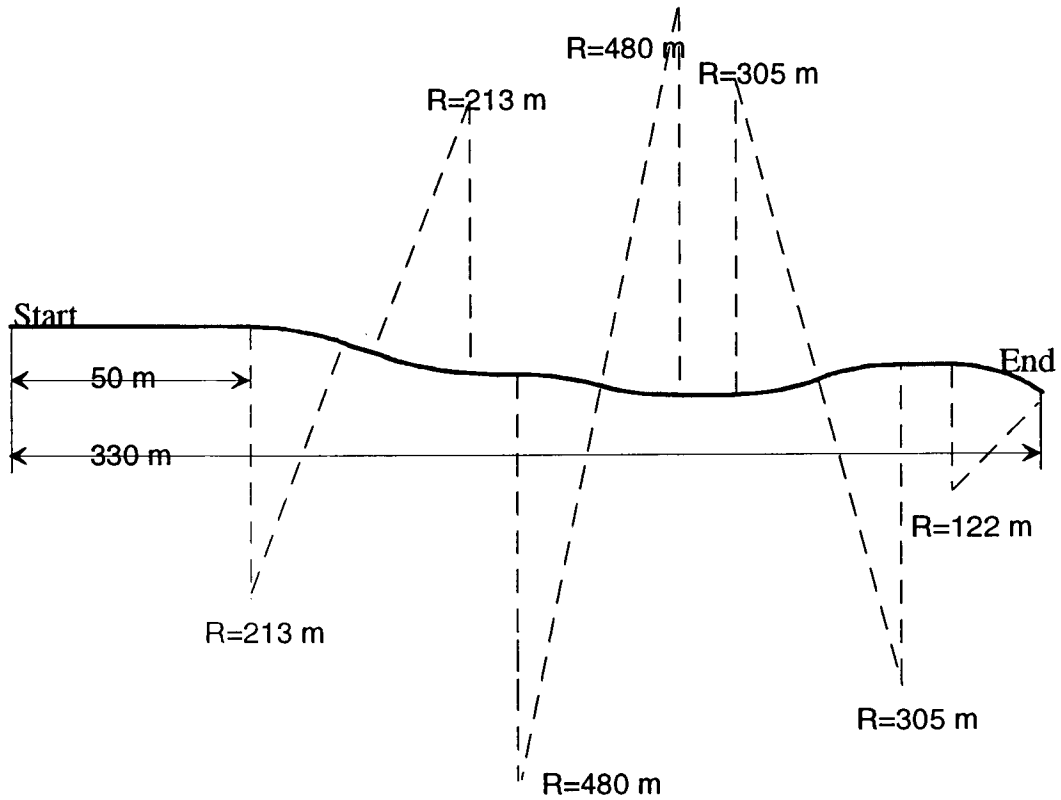

Task 5: Vehicle Guidance Based on Computer Vision

- **Project Description**

Develop visual guidance strategies using a computer vision system, which may be integrated with the magnet-based reference system.

- **Results to Date**

Two visual guidance strategy has been proposed.

- ◆ Visual Guidance Based on Cascade Control System

(by *Wonshik Chee*)

- Analysis of visual measurement has been conducted. (Fig. 1).
- Simulations had been conducted. (Fig. 3).

- ◆ Visual Guidance Using Estimated Position

(by *Alpay Kaya*)

- The vehicle's position and direction (y_{cg} and $\Delta\Psi$) in the road are estimated using the lateral offset measured at two look-ahead distances (Fig. 2).
- A compensator was designed to reduce the effects of the visual measurement delay, achieve a well-damped response, and reduce the steady-state error.
- Simulations were performed for the transition from straight to curved ($r = 500\text{m}$) road and back again (Fig. 4).

- **Future Work**

- Study the combined use of vision and magnet-based reference systems as well as transitions between lane change (vision) and lane following (magnets).

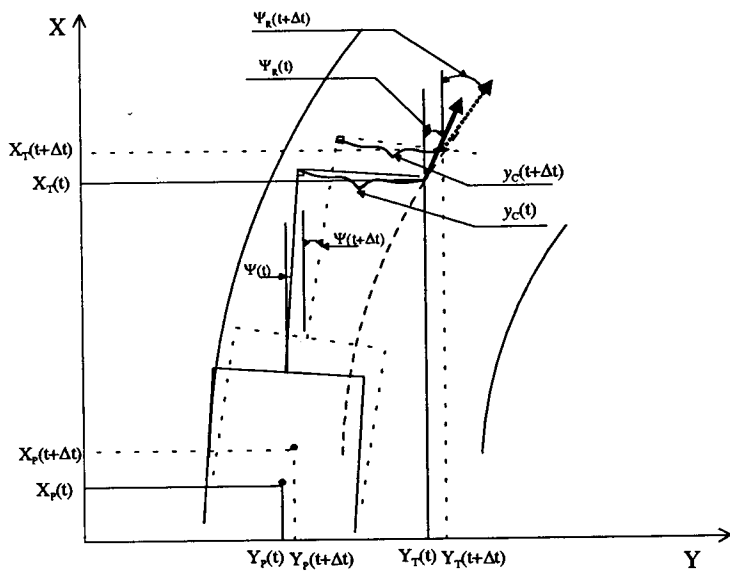

Fig. 1: Analysis of Visual Measurement

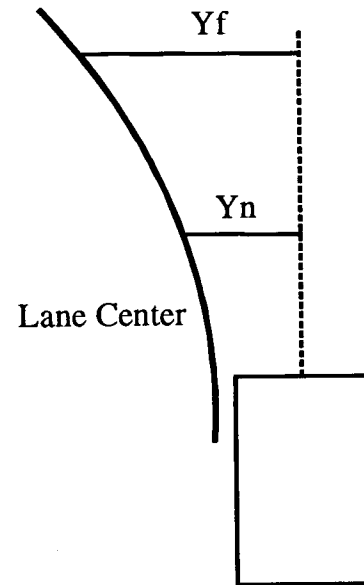

Fig. 2: Lateral Offsets Used to Estimate Position

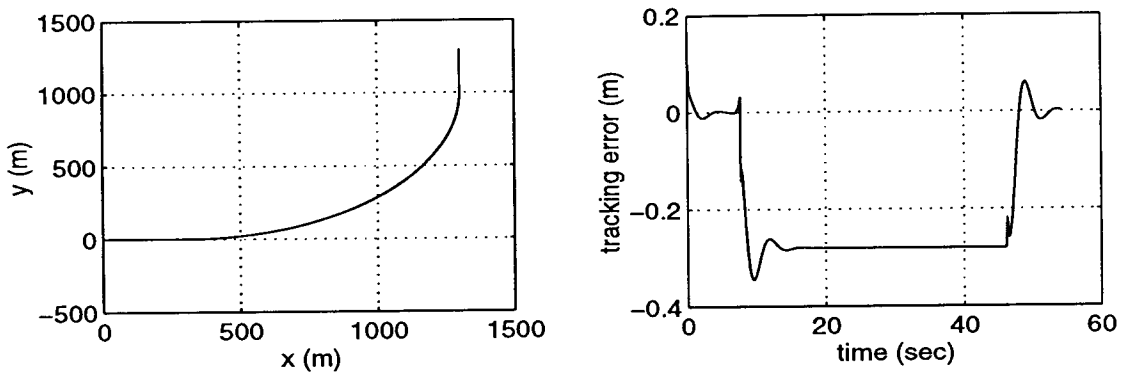

Fig. 3: Simulation of Visual Guidance Based on Cascade Control System

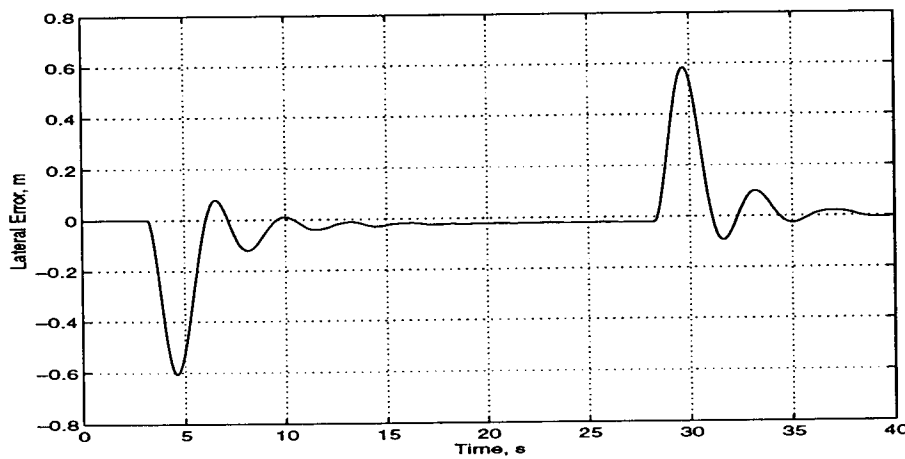

Fig. 4: Simulation of Visual Guidance Using Estimated Position

Visual Guidance Based on Curvature Compensated Offsets

Curvature Compensated Offsets

Highway Model Parameters

$$\frac{1}{R} = \frac{2y_{CVi}}{l_{di}^2 + y_{CVi}^2}$$

$$\theta_i = \frac{\Psi_{j/C} - \Psi_{i/C}}{l_{dj} - l_{di}} l_{di} \quad \theta_j = \frac{\Psi_{j/C} - \Psi_{i/C}}{l_{dj} - l_{di}} l_{dj}$$

$$\text{Curvature Offset } y_{CVi} = \frac{1}{2} l_{di} \theta_i \quad y_{CVj} = \frac{1}{2} l_{dj} \theta_j$$

Curvature -Compensated Offset

$$\eta_i = y_{Ci} - \frac{1}{2} l_{di} \theta_i \quad \eta_j = y_{Cj} - \frac{1}{2} l_{dj} \theta_j$$

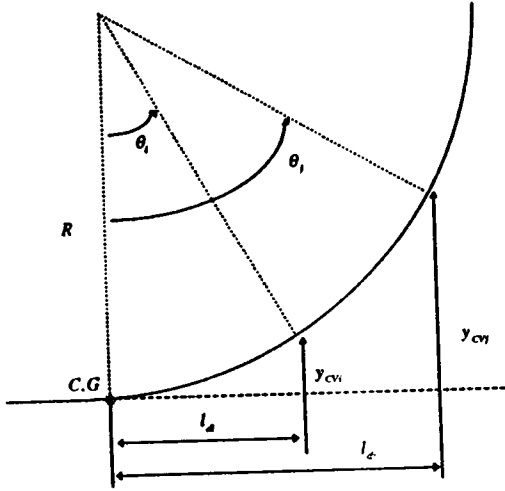

Change rate of road tangent at look head position $r_{Ri} = V_x \cos \Psi_{i/C} \frac{\Psi_{j/C} - \Psi_{i/C}}{l_{dj} - l_{di}}$

Visual Guidance with Curvature Compensated Offsets

$$\begin{aligned} \text{Guidance Goal} \quad y_{CG} &= \frac{l_{dj} \eta_i - l_{di} \eta_j}{l_{dj} - l_{di}} \rightarrow 0 & \Psi_{R/C} &= -\frac{\eta_j - \eta_i}{l_{dj} - l_{di}} \rightarrow 0 \end{aligned}$$

If the desired yaw rate is given as

$$\dot{\Psi}_c = \frac{-\eta_i V_y + \eta_i l_a r_{Ri} + (\eta_j - \eta_i)(l_{dj} r_{Rj} - l_a r_{Ri}) - \frac{1}{2} \frac{r_{Rj} - r_{Ri}}{l_{dj} - l_{di}} (\eta_i l_a^2 + (\eta_j - \eta_i)(l_{di}^2 - l_a^2)) + \lambda_i \eta_i^2 + \lambda_j (\eta_j - \eta_i)^2}{\eta_i l_a + (\eta_j - \eta_i)(l_{dj} - l_a)}$$

Then,

$$\eta_j - \eta_i \rightarrow 0 \quad \text{and} \quad \eta_i \rightarrow 0$$

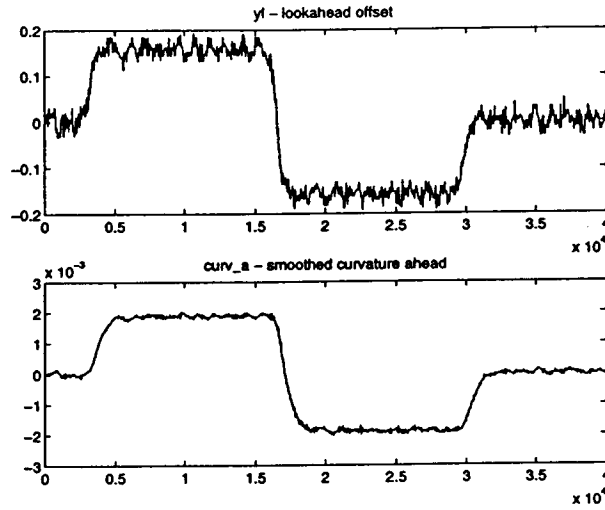

Figure 14: Curvature estimation process. During the simulations plotted in Figure 12, we estimated the curvature of the reference path (lower plot). The true curvature was $K_{ref} = 0.002\text{m}^{-1}$ followed by a segment with $K_{ref} = -0.002\text{m}^{-1}$.

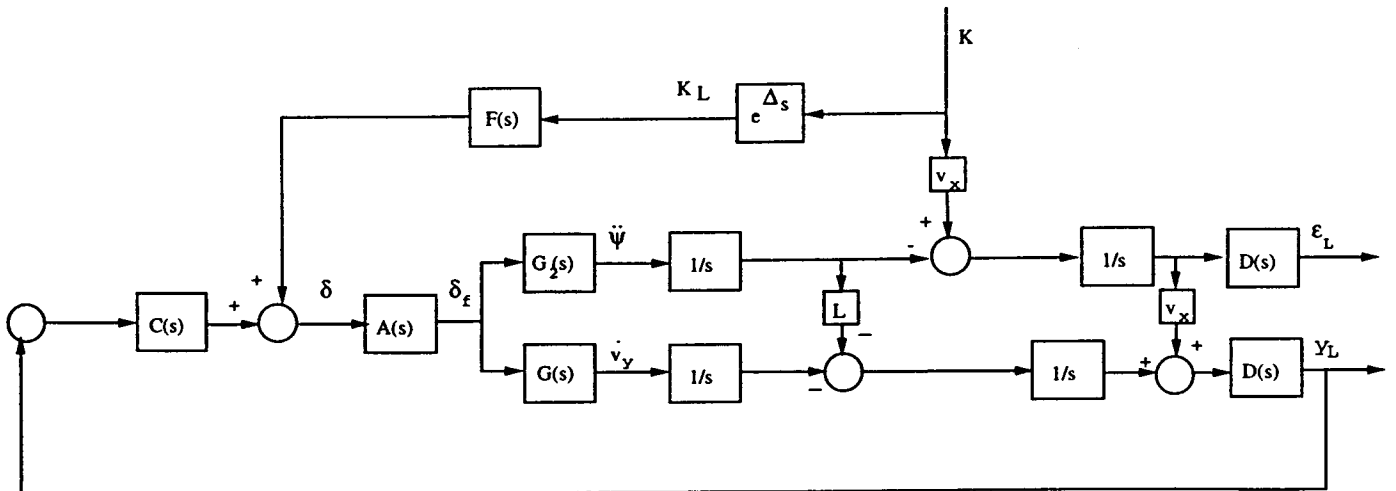

Figure 15: The structure of the controller with the feedback term based on the offset at the look-ahead y_L and curvature based feed-forward term.

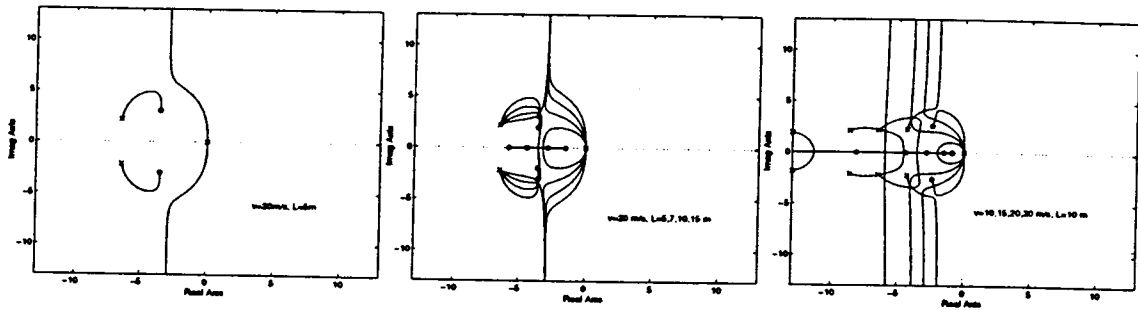

Figure 6: (a) Root locus of the $V_1(s)$ for velocity $v_x = 20\text{m/s}$ and look-ahead distance $L = 15\text{m}$. The double integrator at the origin corresponds to the integrating action between lateral acceleration and position at the look-ahead. The two poles and two zeros in the left half plane characterize the dynamic behavior of the vehicle. (b) Increasing the look-ahead distance L moves the zeros of the transfer function closer to the real axis, which improves their damping. Once they reach the real axis, further increasing of look-ahead doesn't have any effect on damping. The poles of the transfer function are not affected by changes in L since the parameter appears only in the numerator of $V_1(s)$. (c) Root locus of $V_1(s)$ for velocities $v_x = 10,15,20,30\text{m/s}$ and fixed look-ahead distance $L = 10\text{m}$. Increasing the velocity v_x moves both the poles and zeros towards the imaginary axis.

Comments

- Berkeley has the biggest guns in the field
- Most work did not yet make it onto the PATH vehicles

Recommendations 4:

- Continue work
- Adapt emphasis to IVI requirements, including:
 - low speeds for specialty vehicles
 - specialization for truck dynamics
 - specialization for busses
 - specialization for low-friction surfaces

Problem 5: Absolute Position and Motion Measurement

- Subproblems:
 - Lateral control or lateral control backup
 - Prediction for control
 - Prediction for decision-making
 - Detect vehicle slip and slide
- Possible Solutions:
 - On-vehicle sensing - Motion Sensing
 - On-Vehicle Sensing - Absolute Positioning Systems for AHS

NAHSC Activities:

- GPS & Pseudolites
- Inertial
- Optical correlator
- Map building / road preview

NAVIGATION SYSTEMS

Among the first in-car navigation systems was the 1909 Hoffman Road Indicator (shown) which featured a map printed on a tape ran from one spool to another in a small box. A thread spread across the observation glass indicated the position of the car on the road.

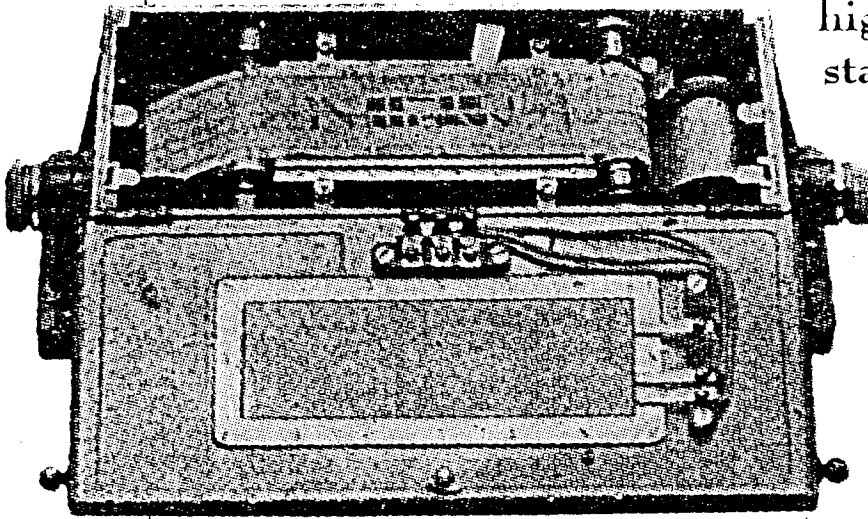

Eighty-five years later high-tech navigational systems started turning up in more and more cars in the U.S., following wide acceptance in Japan and Europe. In the early '90s such systems, which require satellite receivers and CD-Rom drives, were limited to a handful of luxury vehicles.

One of the first nav units to hit the road in the U.S. was Rockwell Automotive's PathMaster, which used a satellite-based global-positioning system, a computer voice and a map on an easy-to-read screen to show the vehicle's location. Other companies, such as Delco, Magneti Marelli, Siemens, Sony, and Bosch also offer navigation systems.

RT2 TECH STATIC

Northing(m) x 10⁻³

temp3

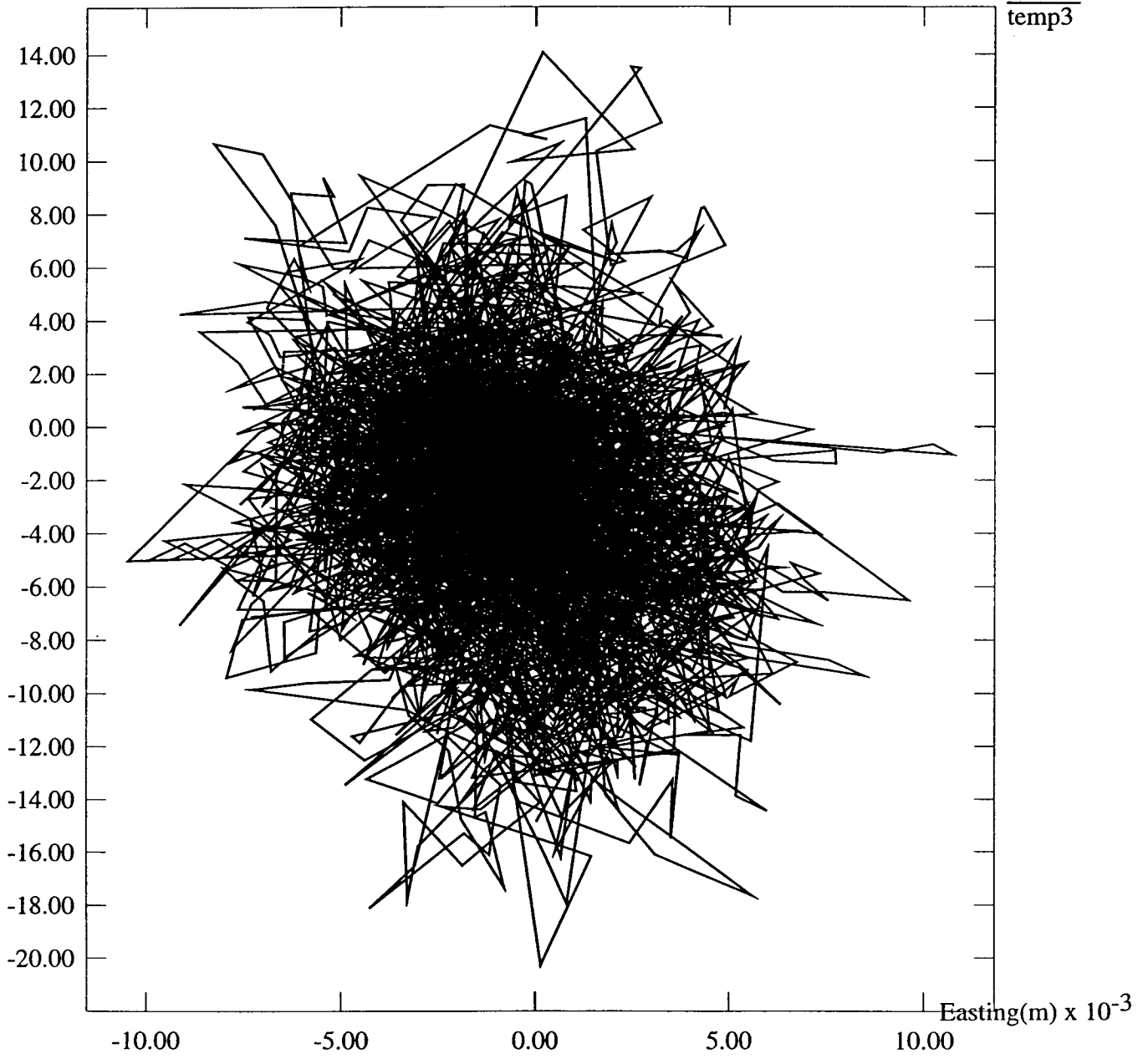

RT2 TECH LOOP

Northing(m)

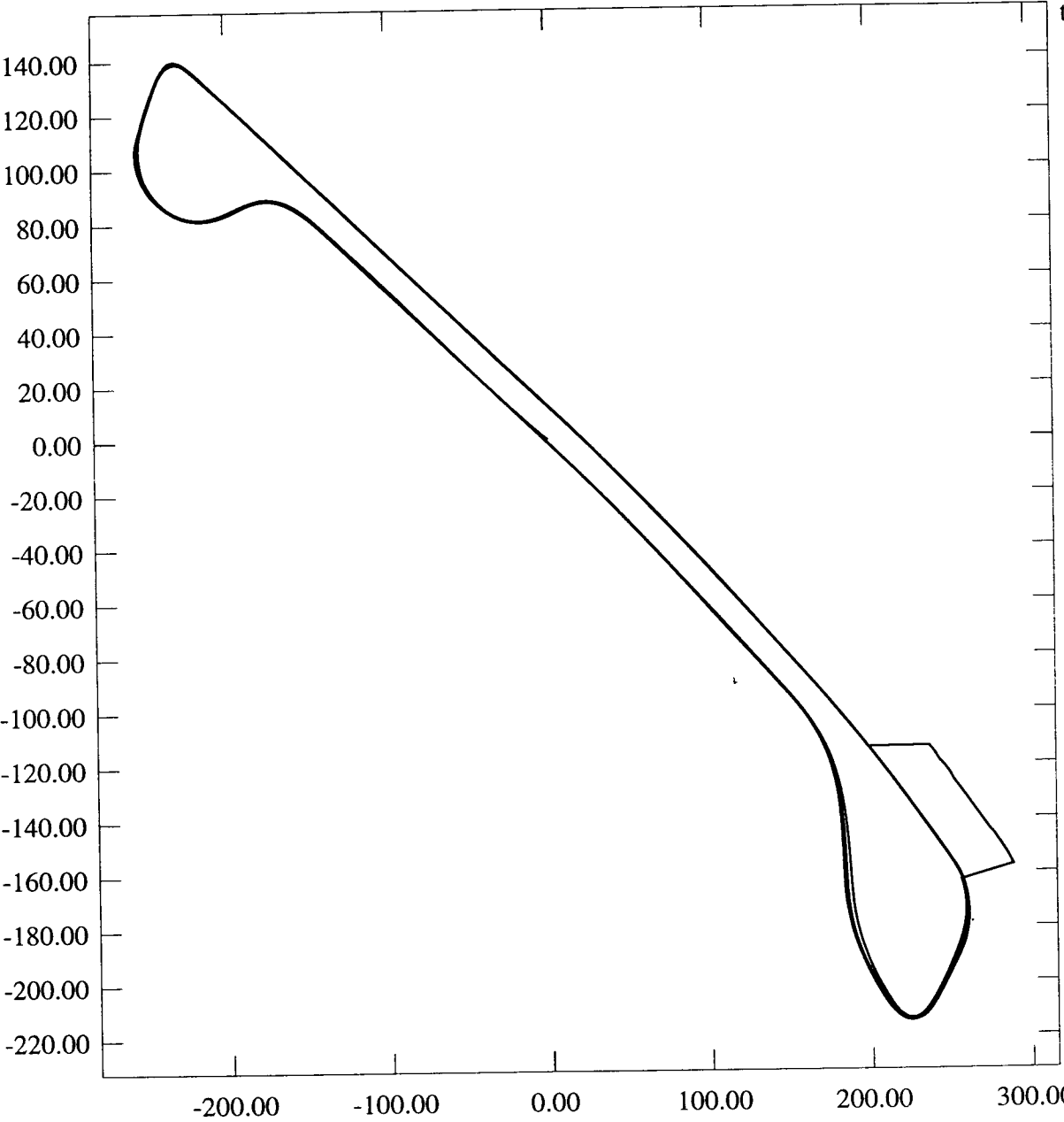

temp3

Easting(m)

RT2 TECH LOOP

Northing(m)

temp3

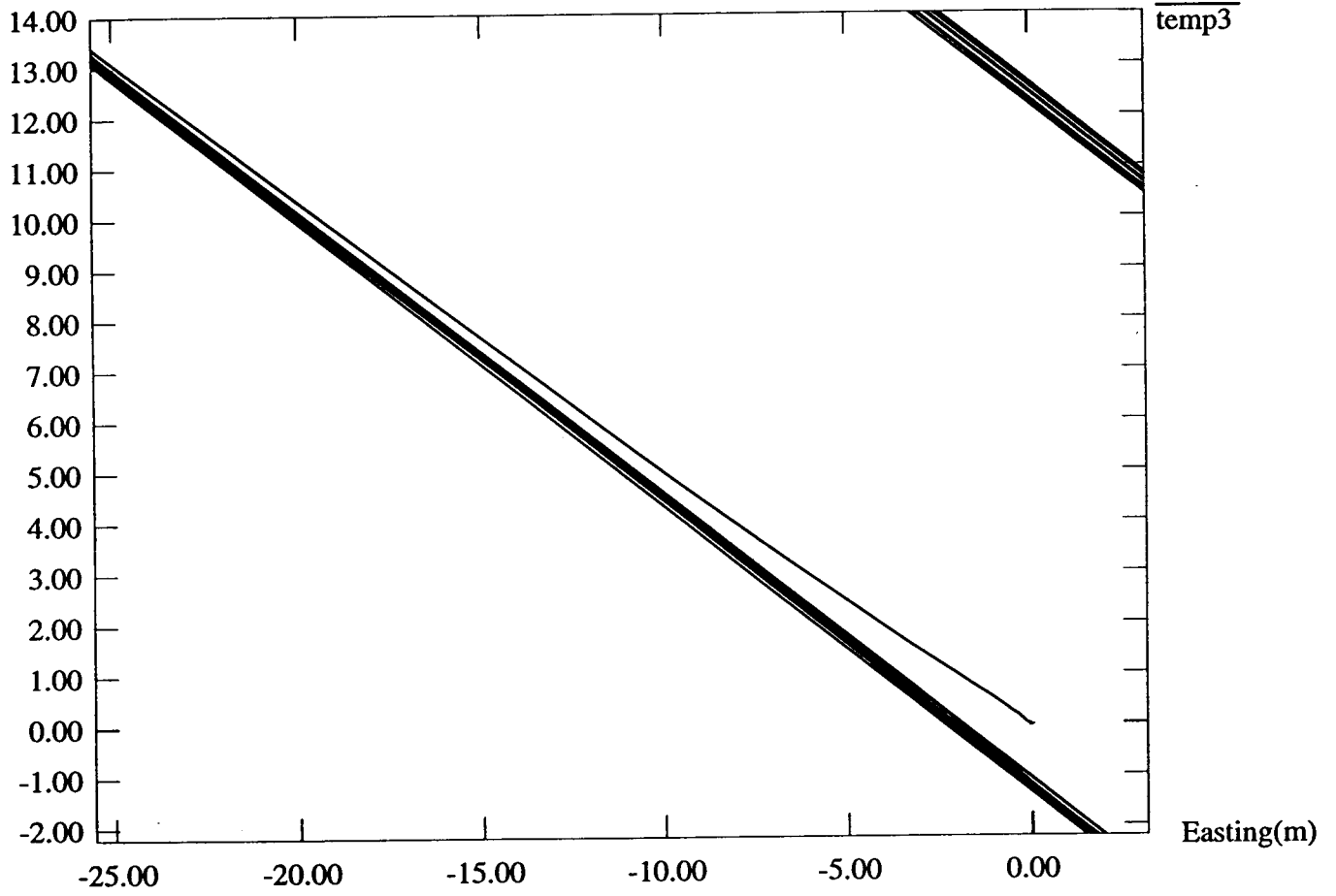

X Graph

Y

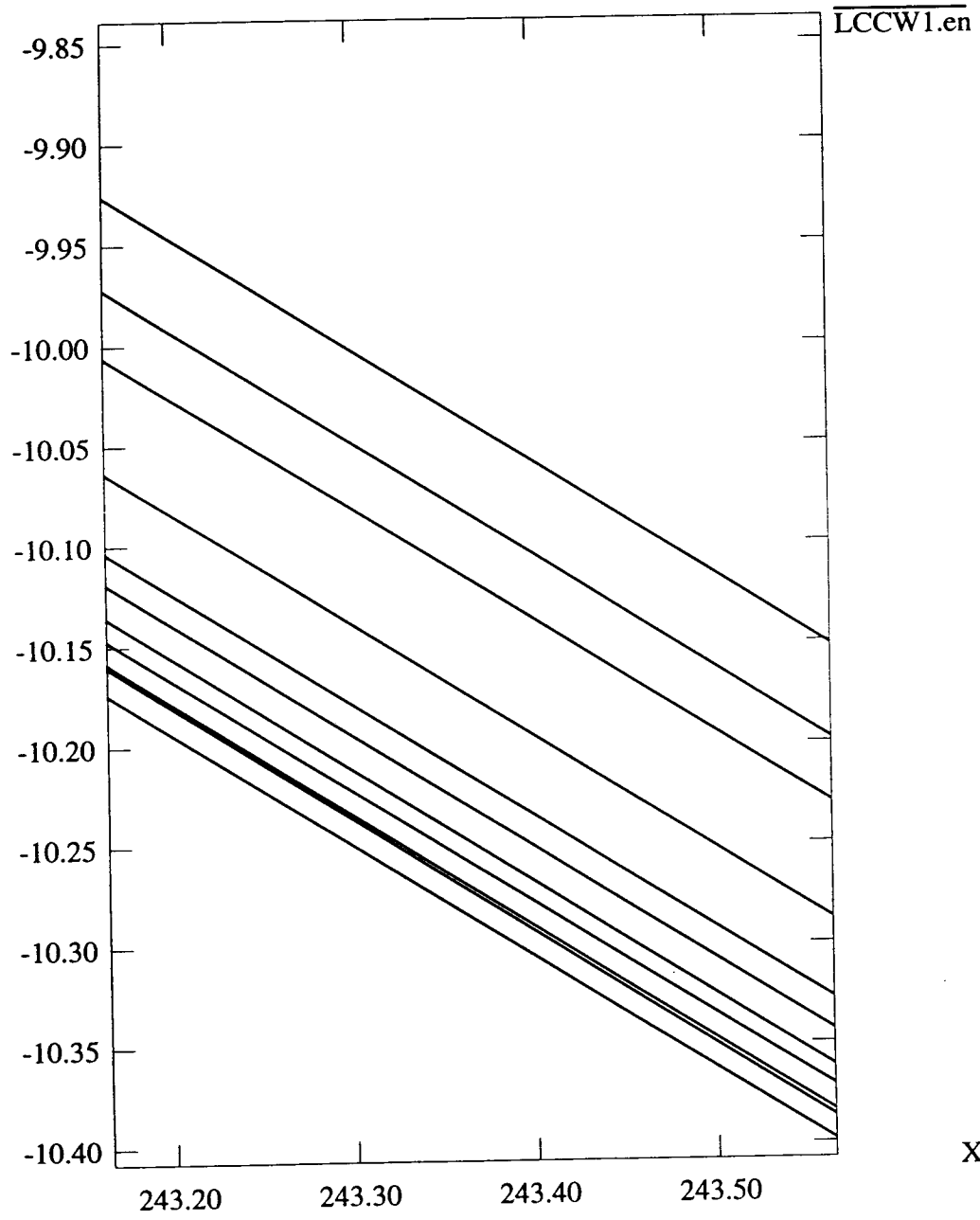

X

GPS - Highway Data

X Graph

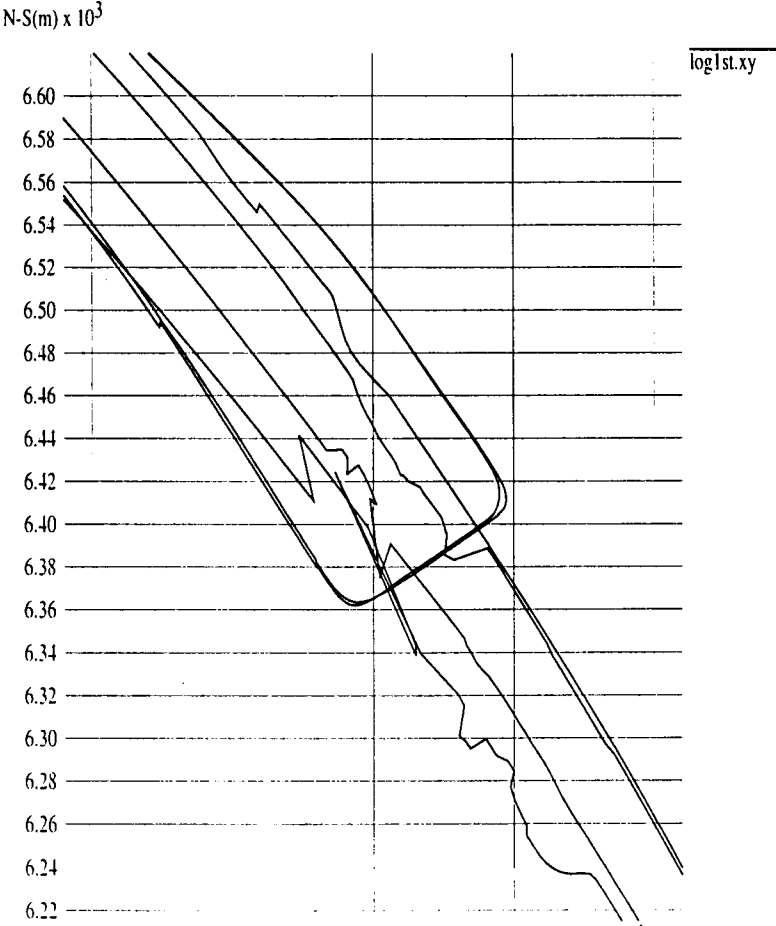

RT2 TECH LOOP

Northing(m)

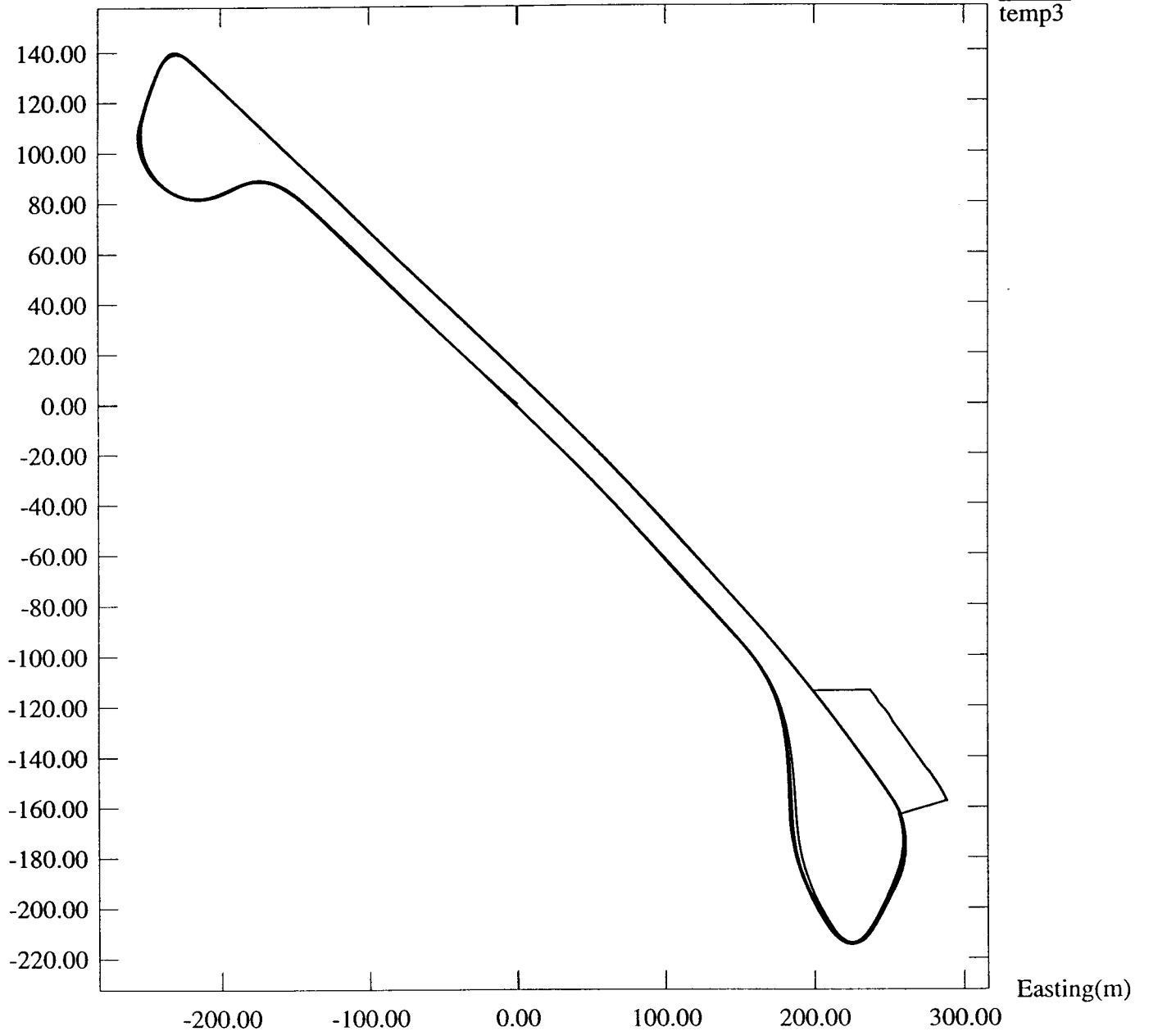

Global Position & Satellites Visible

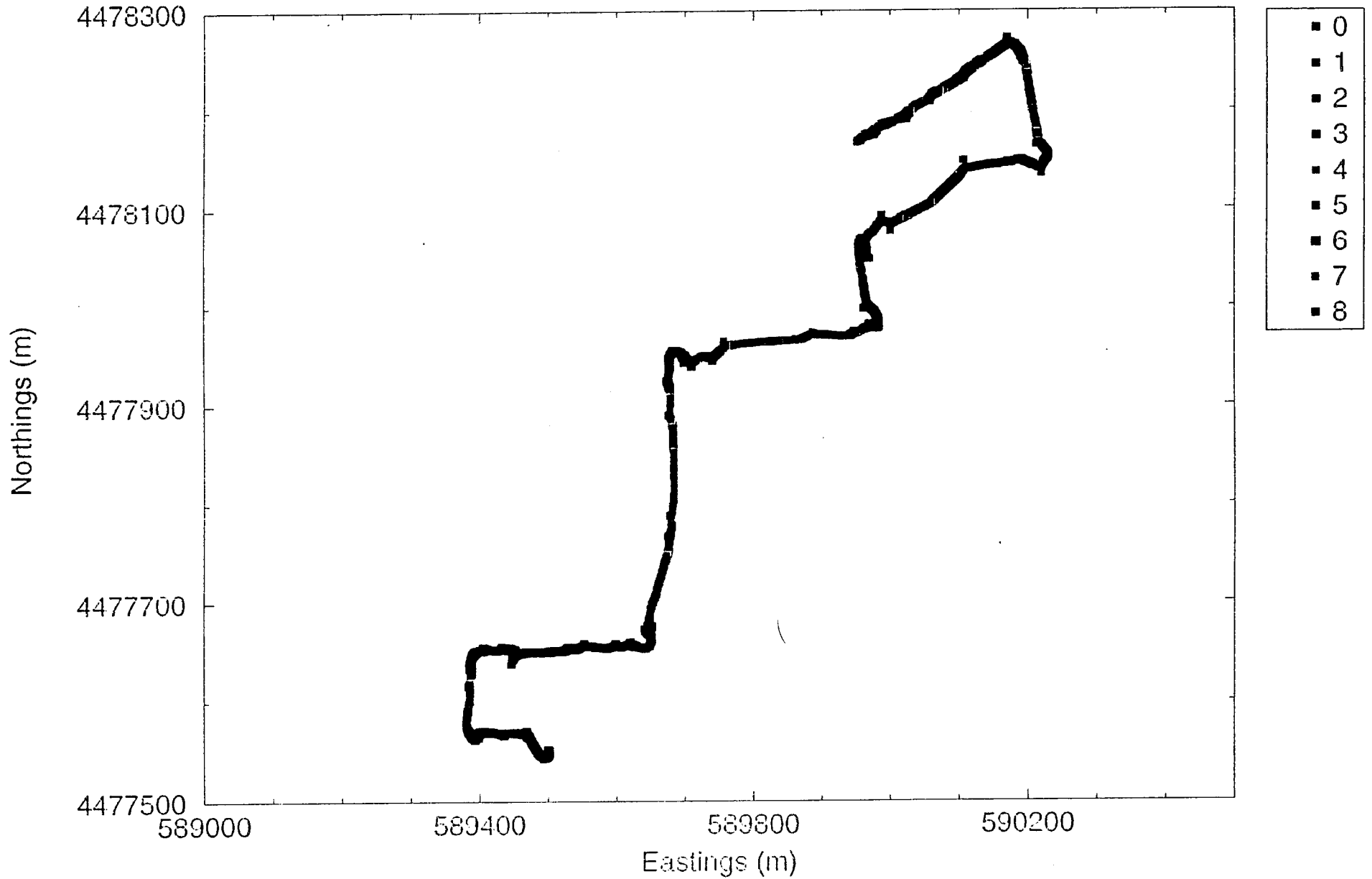

Close Hardcopy About
velocity (m/sec)

GPS Latency

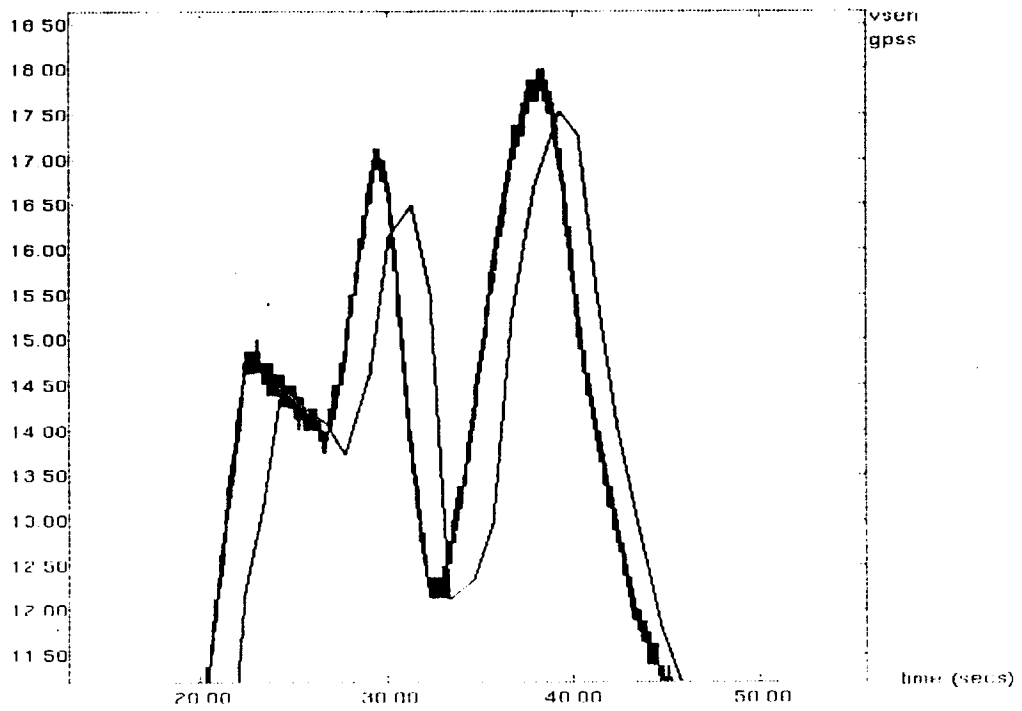

Close Hardcopy About
velocity (m/sec)

GPS Latency

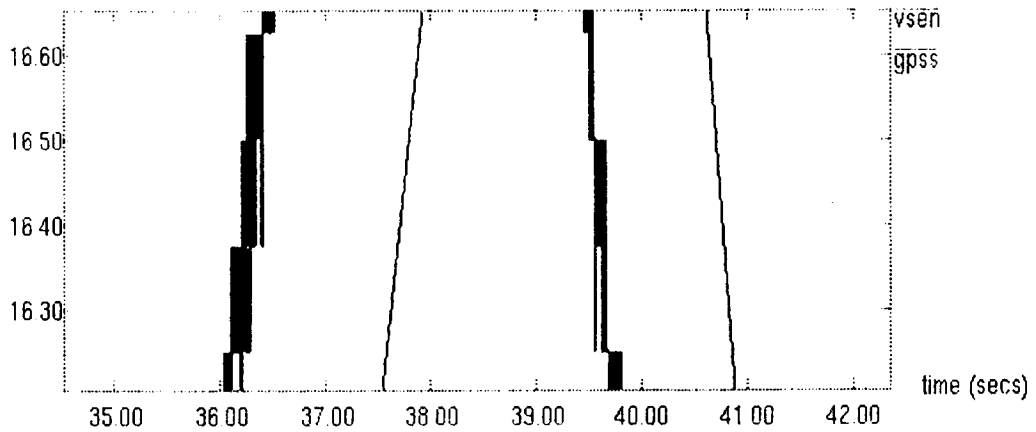

Sensors

- Datron optical correlator DLS-1
 - 0.5 kph to 400 kph
 - 0.2% accuracy
- Andrew Autogyre 225140
 - Bias drift .005 deg/sec (fixed temperature)
- Radar
 - 77 GHz FMCW phased array
 - 0.1 deg azimuth accuracy
 - 0.1 m range accuracy

Distance y [m]

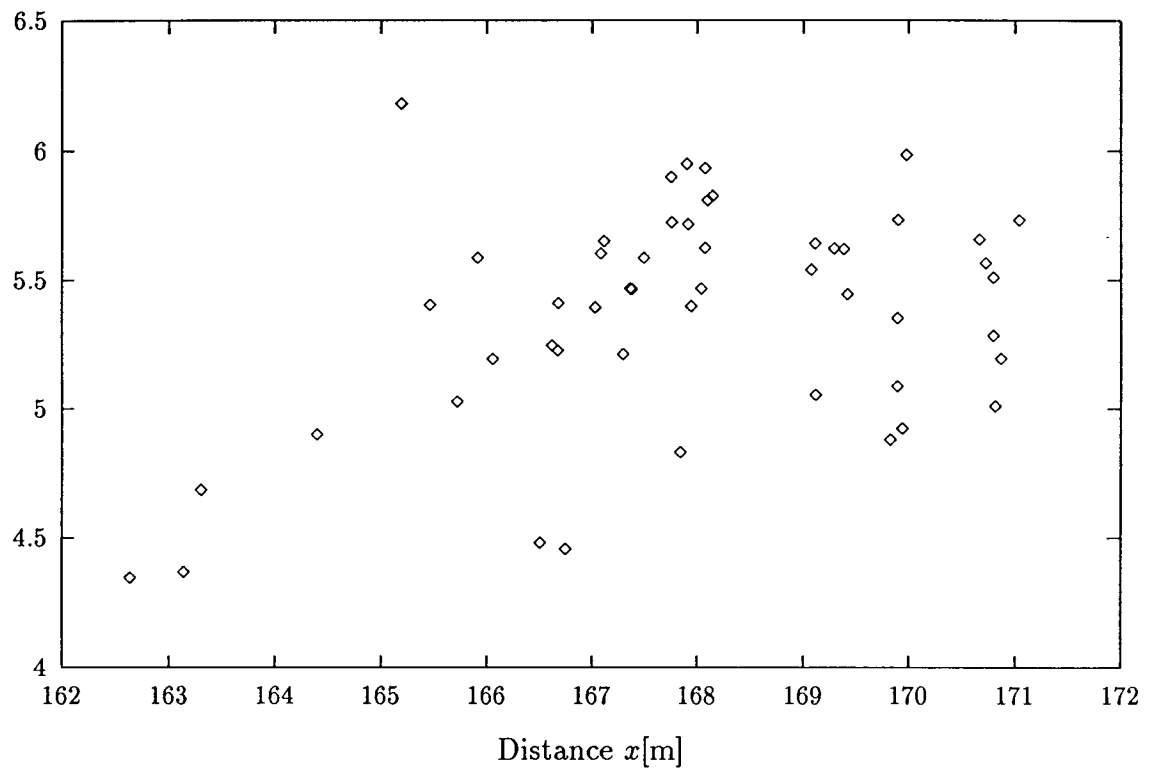

Detected landmark distribution

Distance y [m]

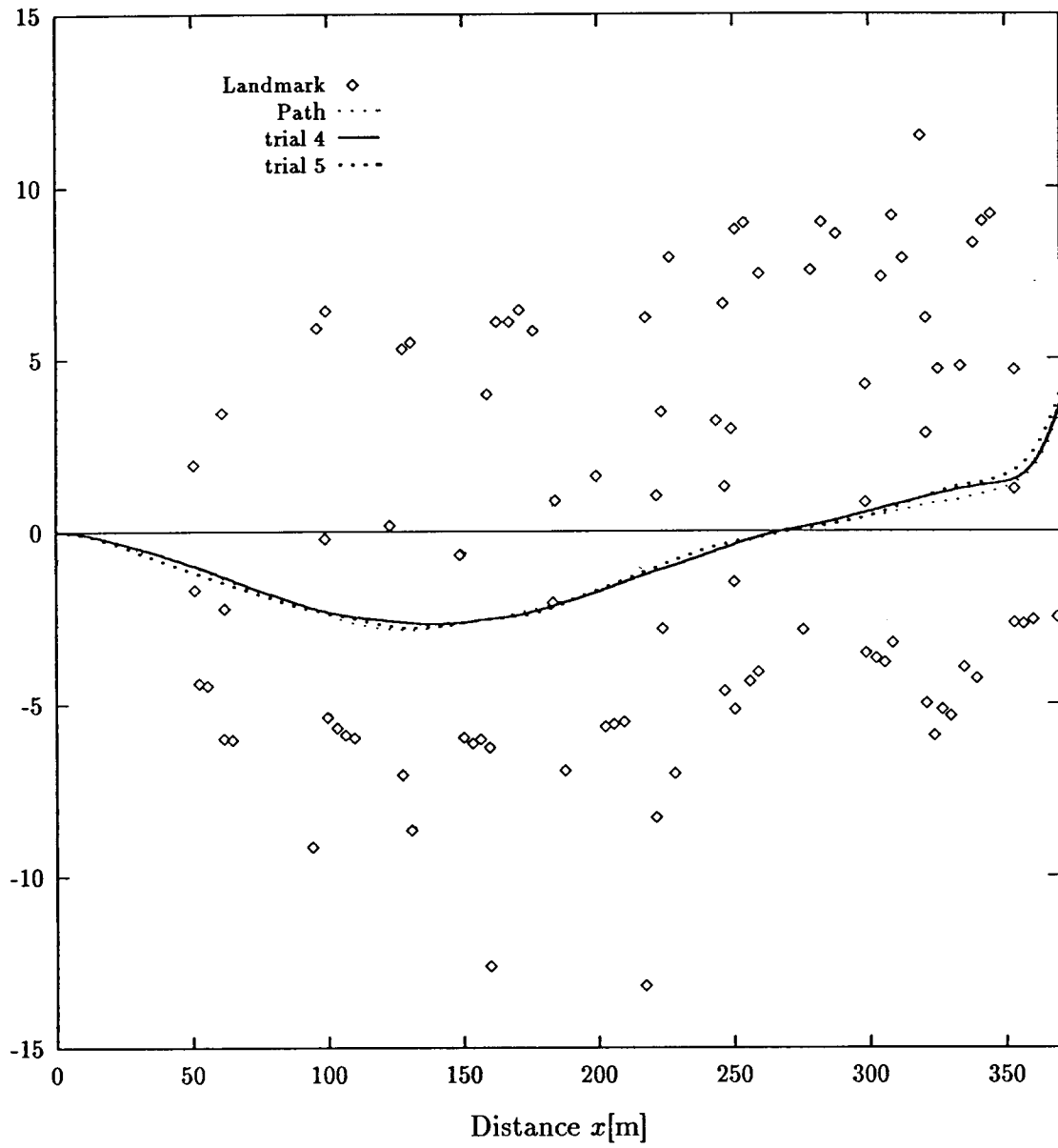

Navigated vehicle trajectories

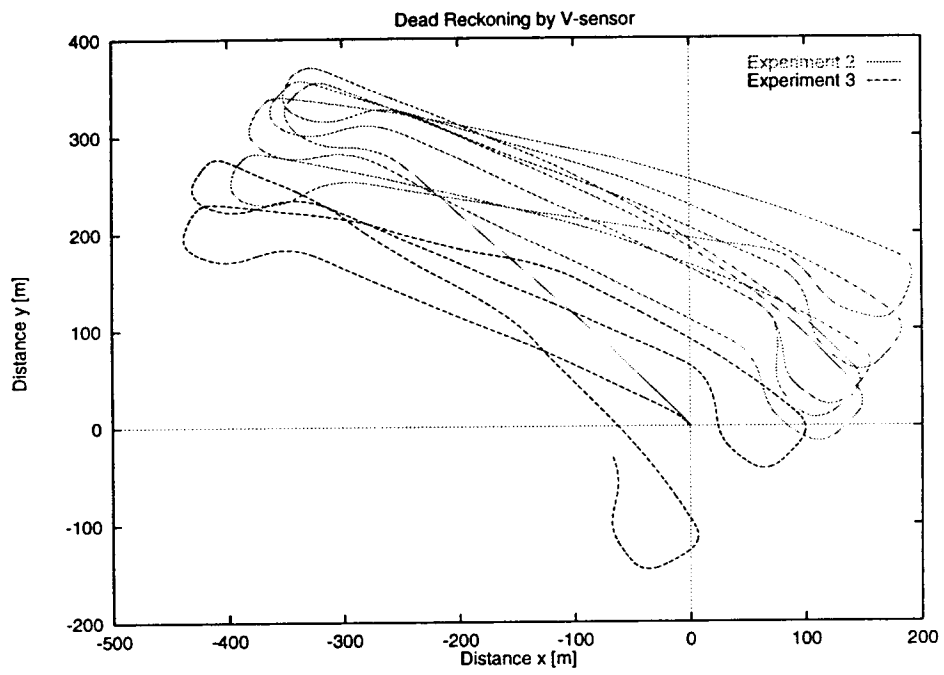

Figure 13: Loci of the vehicle measured by V-sensor. (Experiment 2 and 3)

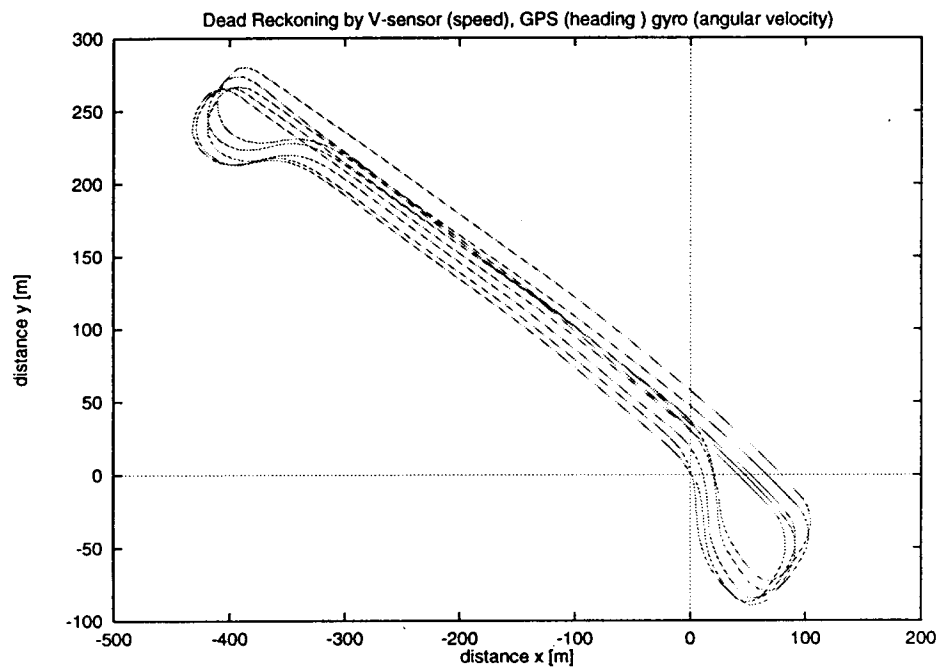
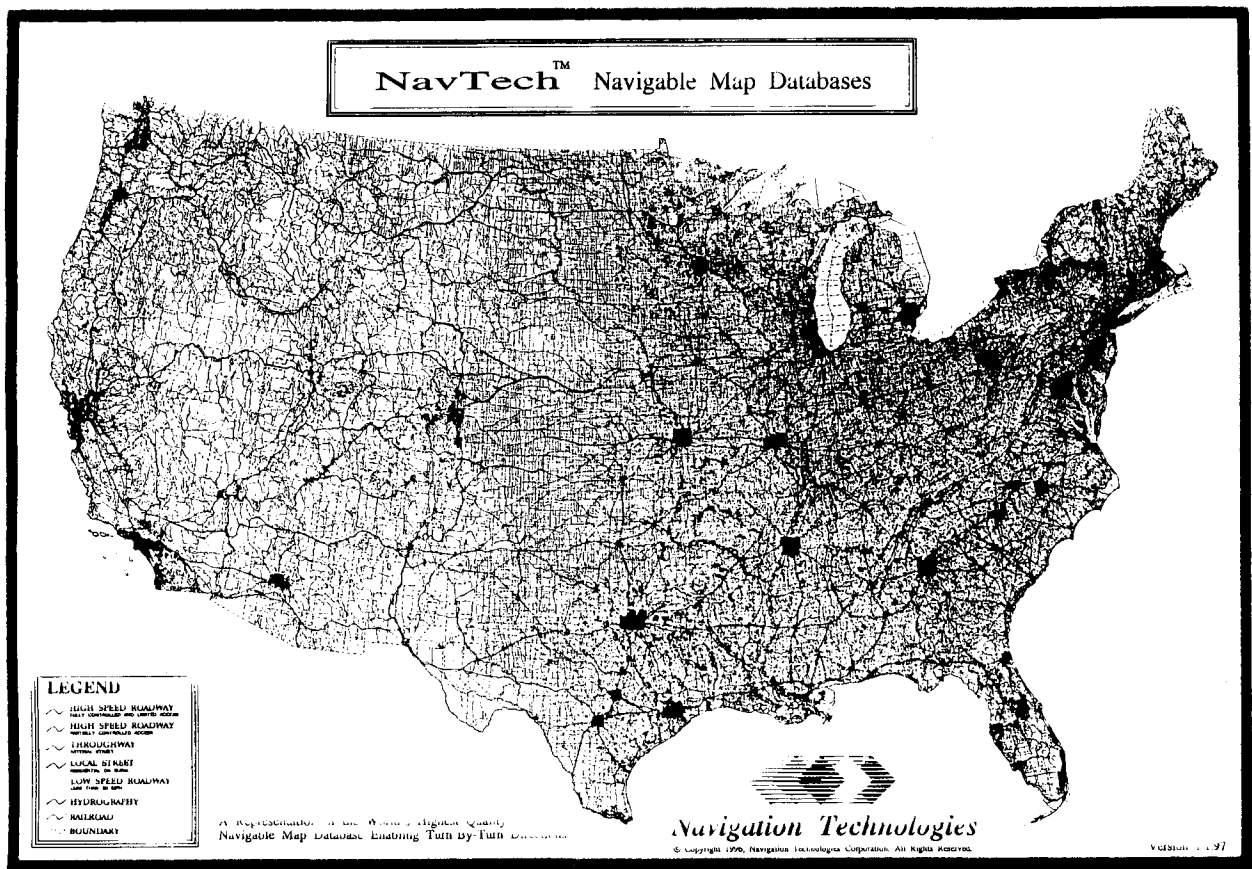

Figure 15: Loci of the vehicle measured by the V-sensor and gyro sensor. The vehicle heading are re-initialized by GPS every second (Experiment 2)



Comments:

- Tied to lane position sensing:
 - mag markers, radar retroreflectors, etc. can generate absolute position as a spin-off
- Requires accurate maps
- Not a first-level requirement

Recommendations 5:

- Watch the big picture
- Get involved with standards
- Continue efforts in motion sensing

Problem 6: How Hard Can I Brake?

- Subproblems:
 - automated control
 - spacing for ACC
 - spacing for driver warning
 - lateral control and warning
- Possible Solutions:
 - On-Vehicle Sensing - Surface Condition
 - Infrastructure Sensing - Surface Condition

NAHSC Activities:

- GM instrumented vehicle
- PB Literature search on local area condition monitoring
- PATH ideas on IR sensing

TIRE - ROAD FRICTION

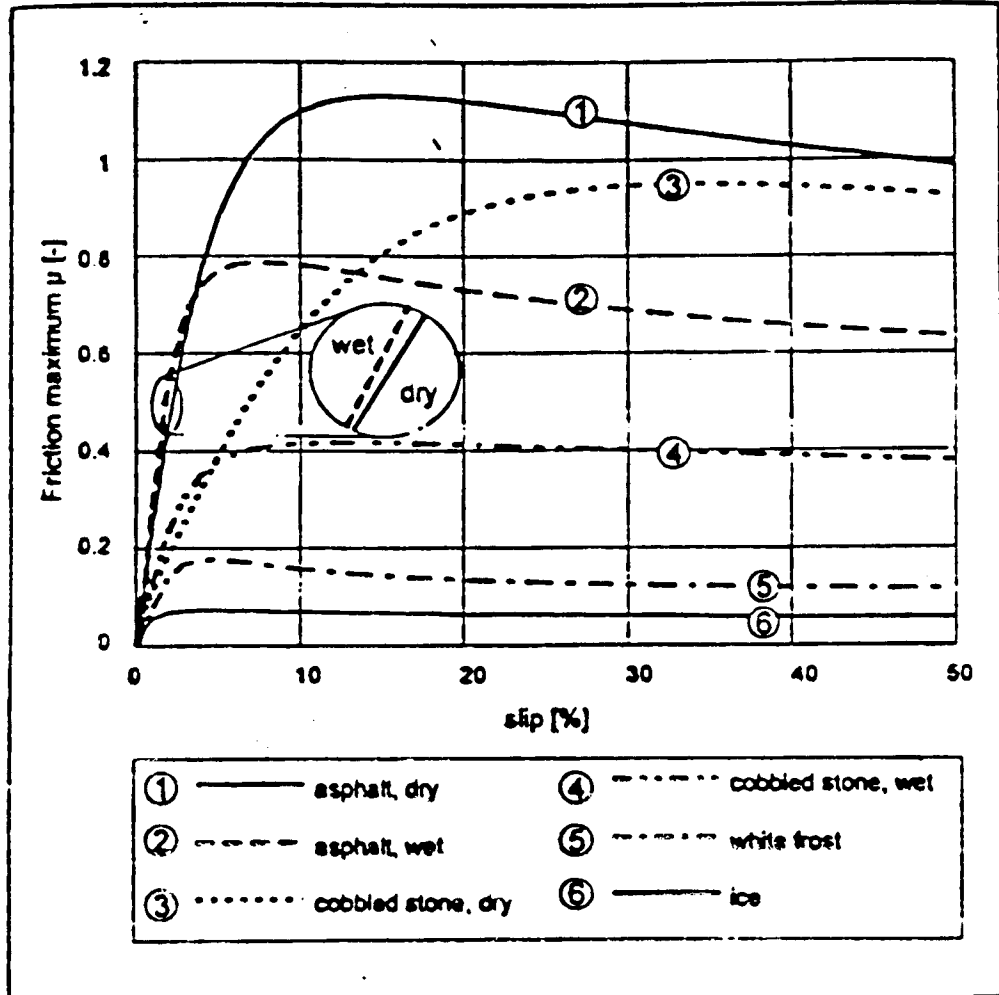

μ -s-curves for varied surfaces and conditions

Tire traction vs slip curve

GM experiments

- High-res wheel speed, axle shaft torque
- Filter wheel speed for acceleration, slip, slope of tractive force / slip
- Measure difference of acceleration front / rear

- Conclusion: Need more testing
- Maybe worth investigating torque sensors

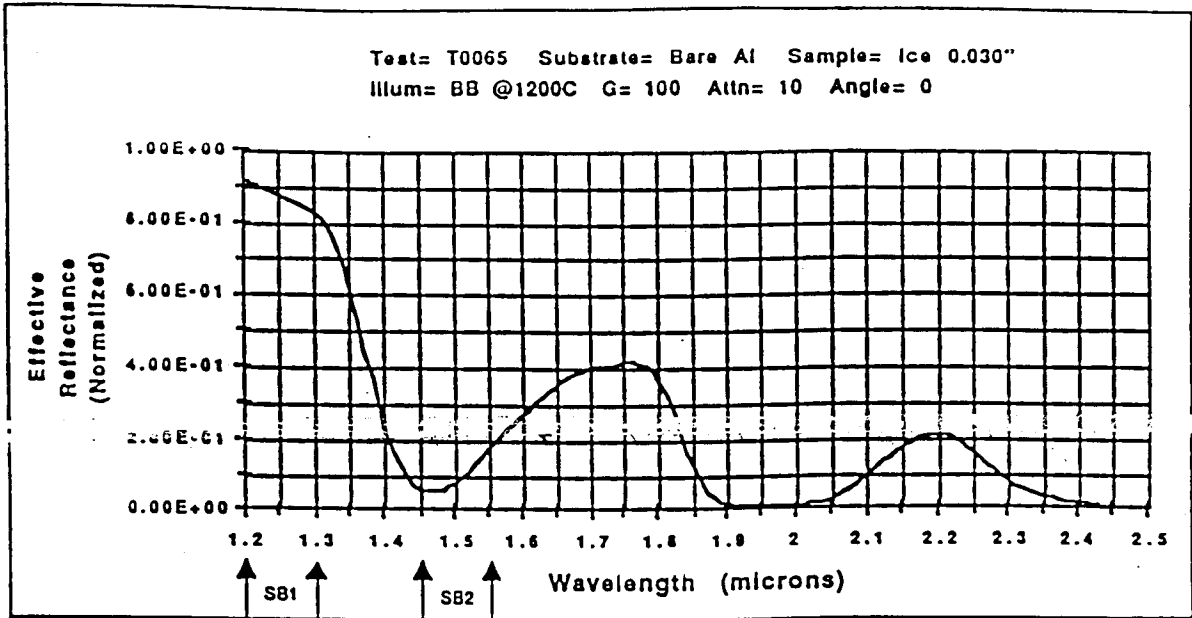

Figure 1. Ice Absorption Spectrum in the NIR.

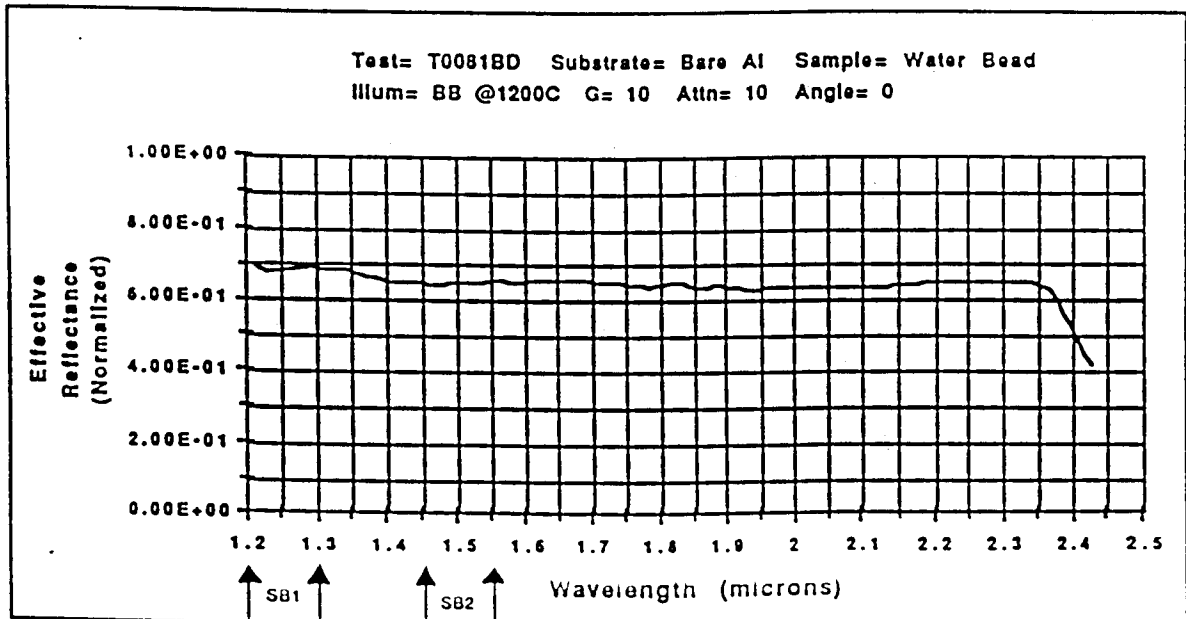
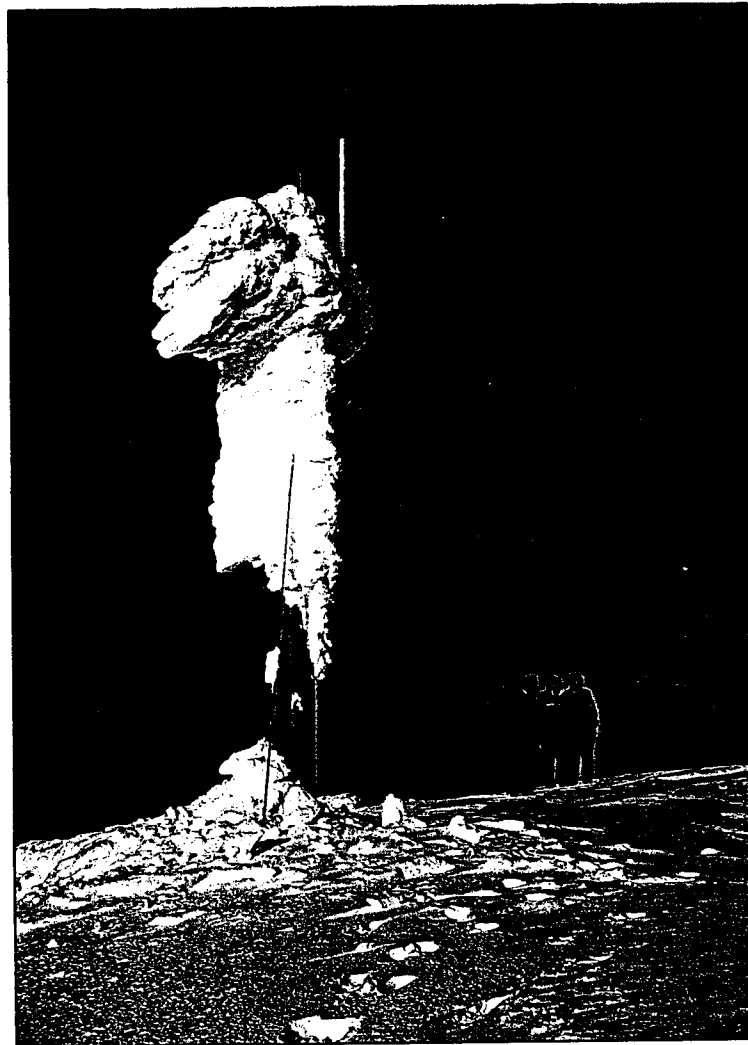

Figure 2. Water Absorption Spectrum in the NIR.

EMI AS **SCAN-MATIC**

PROFESSIONAL PROBLEM-SOLVING
FOR USERS OF
ADVANCED
ELECTRONIC PRODUCTS



Working areas include software development, data acquisition,
control/supervision systems, measuring techniques, transmission techniques,
and underwater acoustics.

AUTOMATIC WEATHER STATION

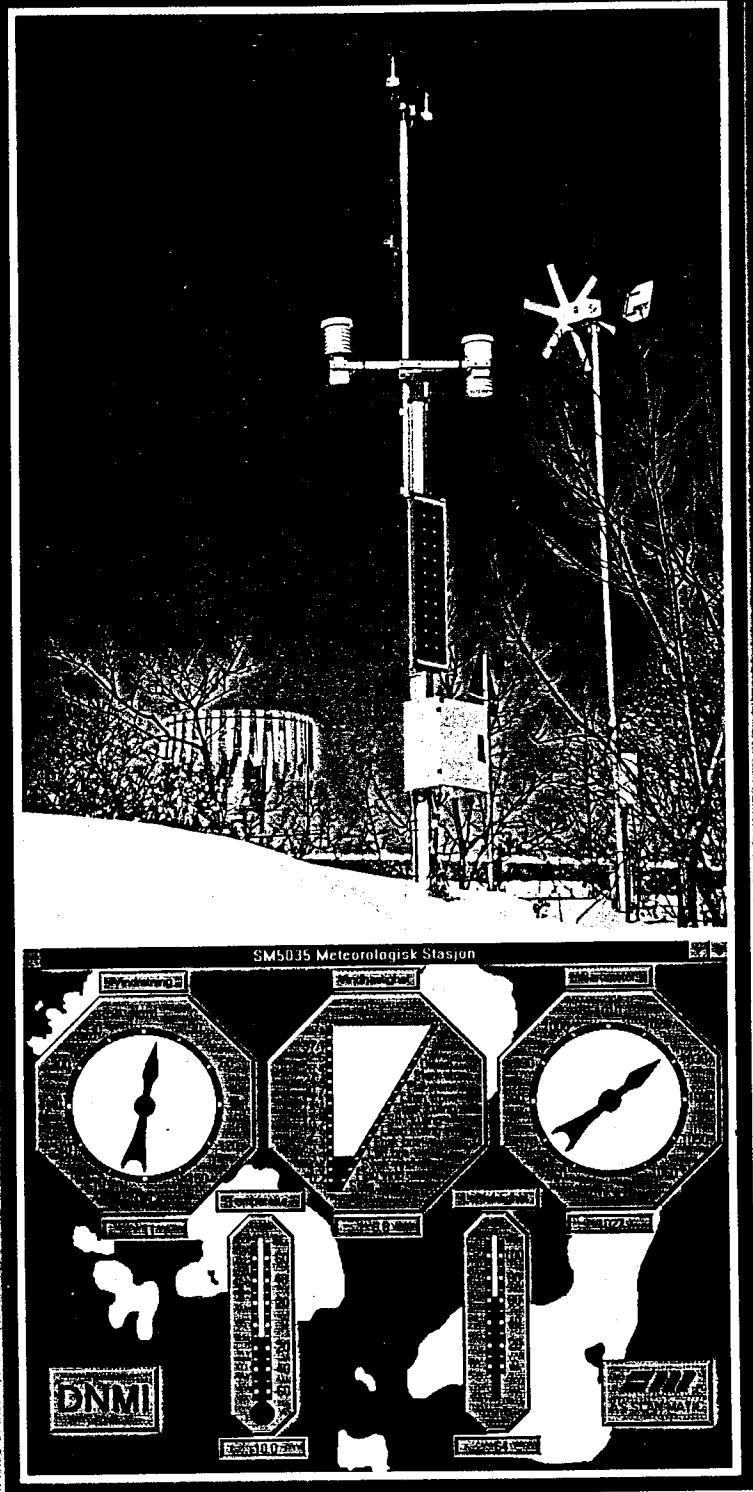

AS SCAN-MATIC

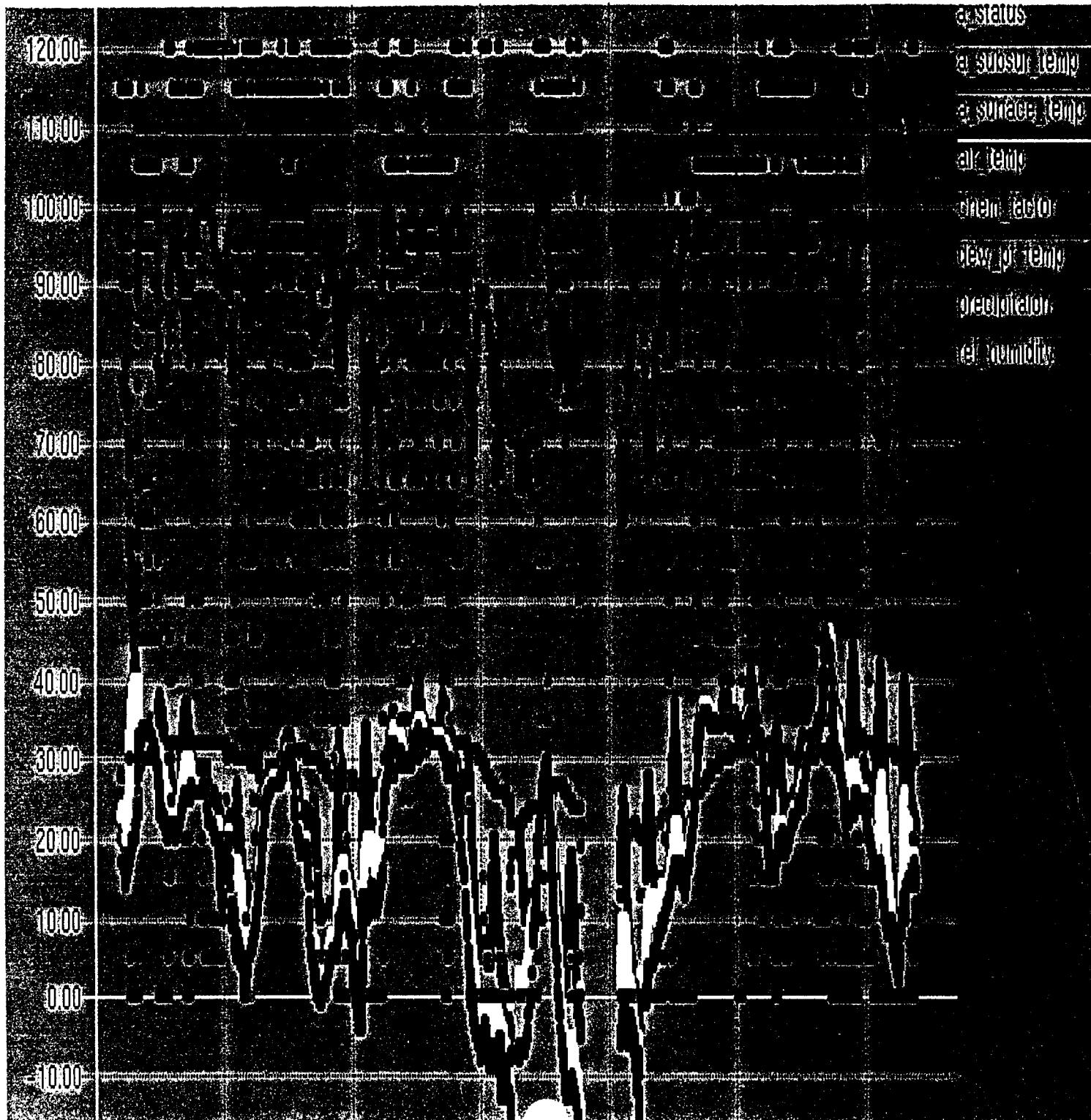

Comments:

- Very tough but crucial problem
- Infrastructure solutions continue to improve, but not very well localised

Recommendations 6:

- Listen for great ideas
- Listen to improvements in weather sensing

Problem 7: Vehicle-Vehicle Communications

- Subproblems:
 - platoon requirements for high-reliability, low-latency
 - ACC requirements less stringent
 - different system designs possible for different communications capabilities
- Possible Solutions:
 - Communications - Vehicle-To-Vehicle
 - Communications-Vehicle-To-Roadside

NAHSC Activities:

- Hughes (Raytheon) lead on system design
- PATH efforts on IR comm

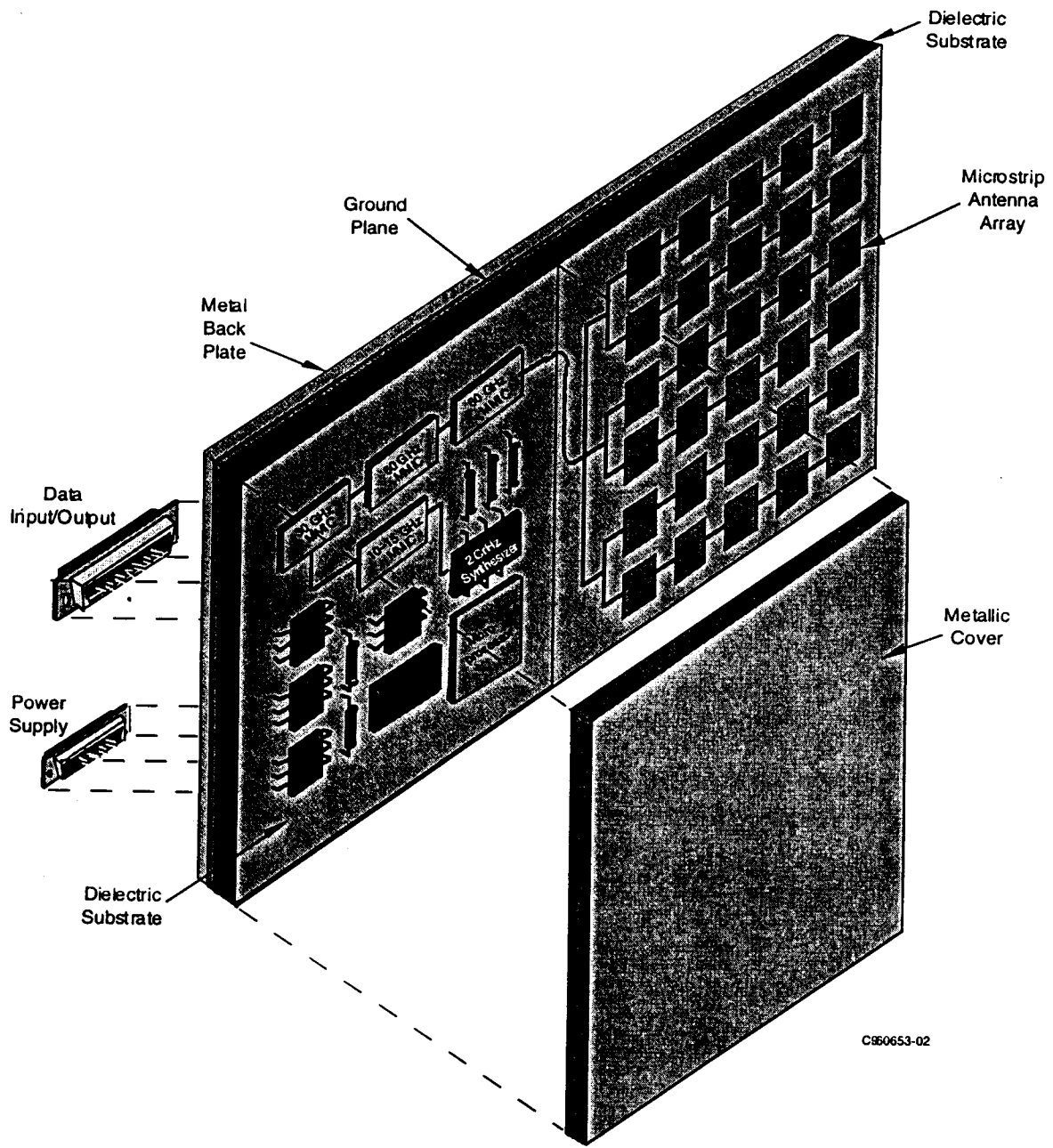

Figure A-2. Details the Complete 60 GHz Transceiver Assembly

Comments:

- Lots of issues:
 - identifying transmitter
 - potentially high volume of comm traffic within range
 - overall architecture and protocol
 - directional vs. broadcast
 - radio vs. IR
 - making and breaking LANs on the fly
 - central coordinator vs. local self-organization

Recommendations 7:

- Needs significant work
- Needs close interaction with the design process

Problem 8: Reliability

- Subproblems:
 - software
 - hardware
 - hackers
 - Intel, Microsoft, IDB, ...
- Possible Solutions:
 - Algorithms: Software Safety
 - Processing - On-Board

NAHSC Activities:

- PATH work on software safety
- CMU work on C-40 design
- Background on Unix reliability
- Safety by system design (e.g. platoons)

Why Dependability Is Difficult

- Cost sensitivity
 - Brute force redundancy costs too much
 - Creative solutions: heterogeneous redundancy?
- Equipment used until end-of-life
 - Most dependability techniques assume flat part of the “bathtub” curve for failure rates
 - Operators do not necessarily repair equipment if it still functions
- Operation in uncontrolled environment
 - Vehicles are a harsher environment than machine rooms

Why Dependability Is Difficult-2

- Most operators are relatively unskilled, untrained
 - May not realize when something is going wrong
 - May not react appropriately in an emergency
- Safety-critical software is very difficult
 - Writing & certifying safety-critical software is extremely expensive, and is a very new concept to the automotive industry
 - Interaction of vehicles & components from various manufacturers complicates situation
 - Nobody has a complete answer, let alone a cheap one
 - There is no reasonable way to “prove” software system is safe

Why Dependability Is Difficult --

3

- Very large scale of deployment
 - Training, certification, inspection of safety-critical subsystem maintenance facilities
 - Investigation of system failures (will NTSB investigate thousands of accidents?)
 - Cost of correcting “bugs” via recall
 - Vulnerability of equipment to tampering or vandalism
 - Inevitability of runs of bad luck, decreasing public confidence

Tandem System Outages

	<u>1985</u>	<u>1987</u>	<u>1989</u>
Customers	1000	1300	2000
Outage Customers	176	205	164
Systems	2,400	6,000	9,000
Processors	7,000	15,000	25,500
Discs	16,000	46,000	74,000
Reported Outages	285	294	438
System MTBF	8 years	20 years	21 years

Lemons Or Just Statistics?

Poisson distributed failures: $P(x) = \frac{(\lambda)^x}{x!} e^{-\lambda}$ $x = 0, 1, 2, \dots$

<u>Annual failures for 100,000,000 vehicles</u>	<u>Vehicles failing given 10 year MTBF</u>	<u>Vehicles failing given 100 year MTB</u>
0	90,483,741	99,004,983
1	9,048,374	990,050
2	452,419	4,950
3	15,081	17
4	377	0
5	8	0
6	0	0

Testing and Performance of Sensors for Lateral Control of Vehicles

Andrew C. Segal
James Bret Michael
Han-Shue Tan
Satyajit Patwardhan

INTRODUCTION

- ◆ SOFTWARE TESTING AND SOFTWARE ANALYSIS OF LATERAL CONTROLLER
- ◆ PERFORMANCE EVALUATION OF LATERAL CONTROLLER
- ◆ ROBUSTNESS AND SAFETY OF THE SYSTEM



CALIFORNIA PATH HEADQUARTERS
University of California, Berkeley
Institute of Transportation Studies
Richmond Field Station
1301 S. 46th St., Bldg. 452
Richmond, CA 94804
Tel: (510) 231-9495 FAX: (510) 231-9565

2

ACS 10/1/95

PATH LATERAL CONTROL SYSTEM

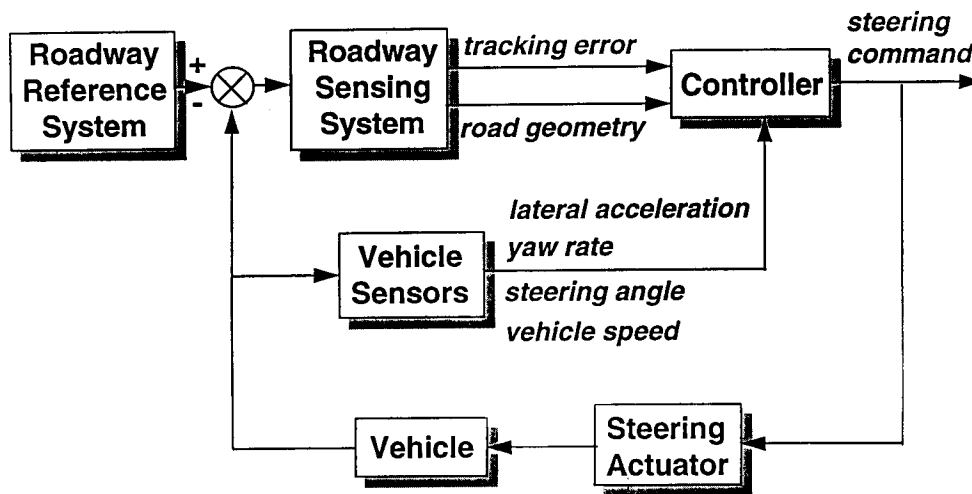

CALIFORNIA PATH HEADQUARTERS
University of California, Berkeley
Institute of Transportation Studies
Richmond Field Station
1301 S. 46th St., Bldg. 452
Richmond, CA 94804
Tel: (510) 231-9495 FAX: (510) 231-9565

4

ACS 10/1/95

VALIDATION OF TEST RESULTS

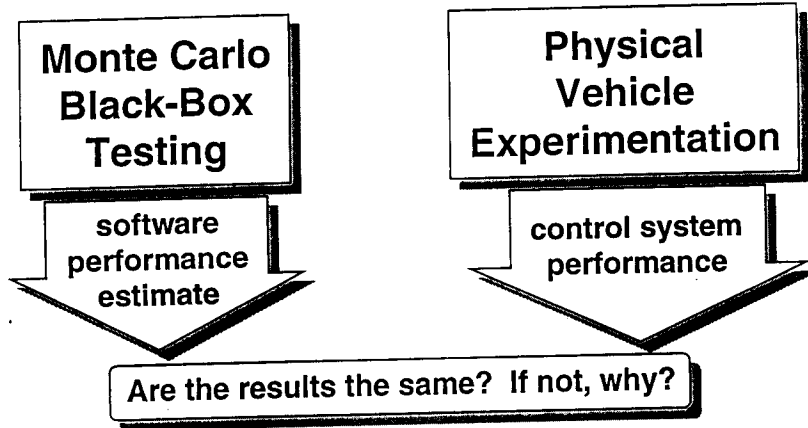

MONTE CARLO BLACK BOX TESTING

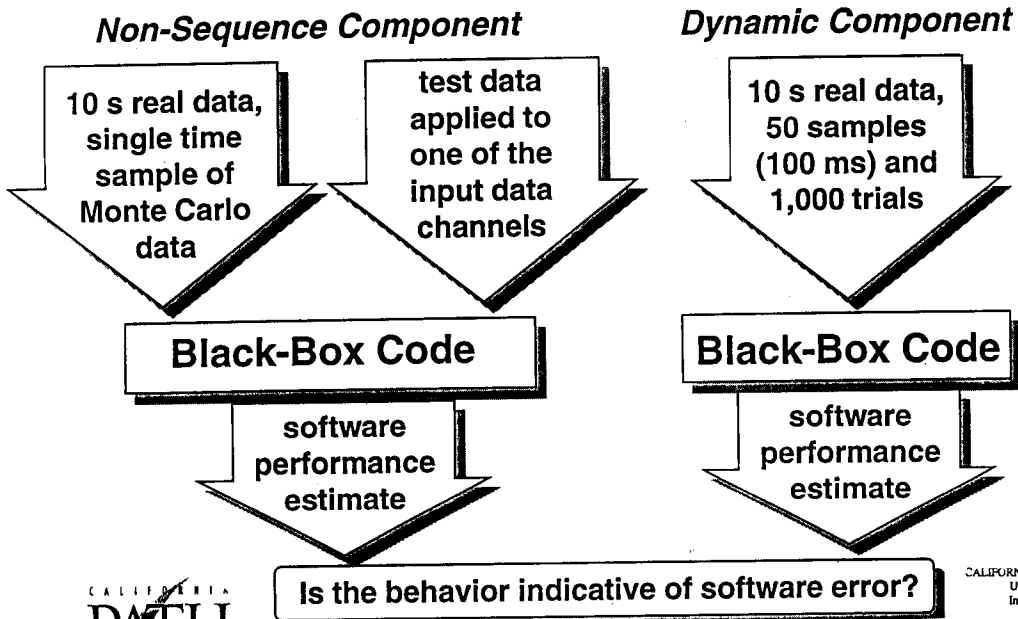

PHYSICAL EXPERIMENTATION

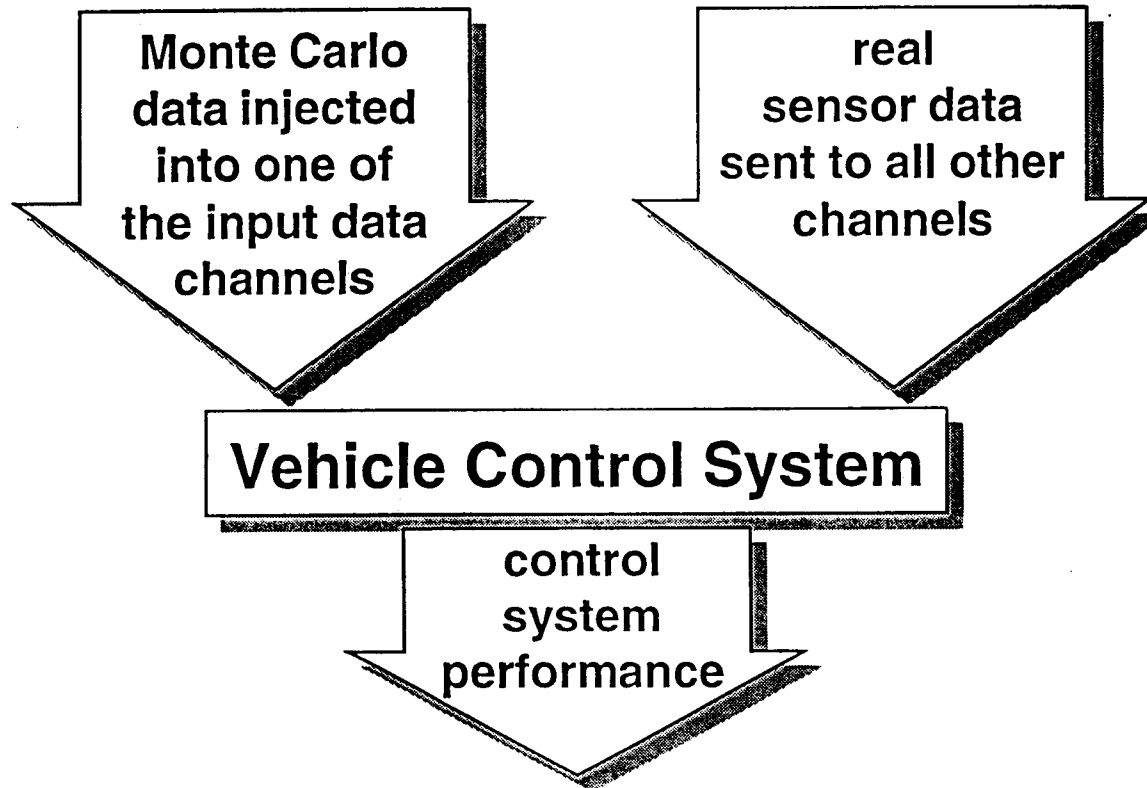

Does the control system display anomalous or incorrect behavior?

Probability of Failure vs. Time Plots

Honeywell assumed that the overall AHS probability of failure must be less than 1×10^{-6} in their probability of failure plots. Based on this, they have calculated probabilities for both duplex and triplex modular redundancy in most of the subsystems. In the following plots, all assumptions are as specified in the Honeywell report. All subsystem and system reliabilities are calculated using the series and parallel reliability equations.

Steering

Three mechanizations are demonstrated for the steering subsystem. The safety diagram for the first subsystem is shown in Figure 1. Figure 2 shows the Matlab plot and Table 1 shows the data used to generate the Matlab plots.

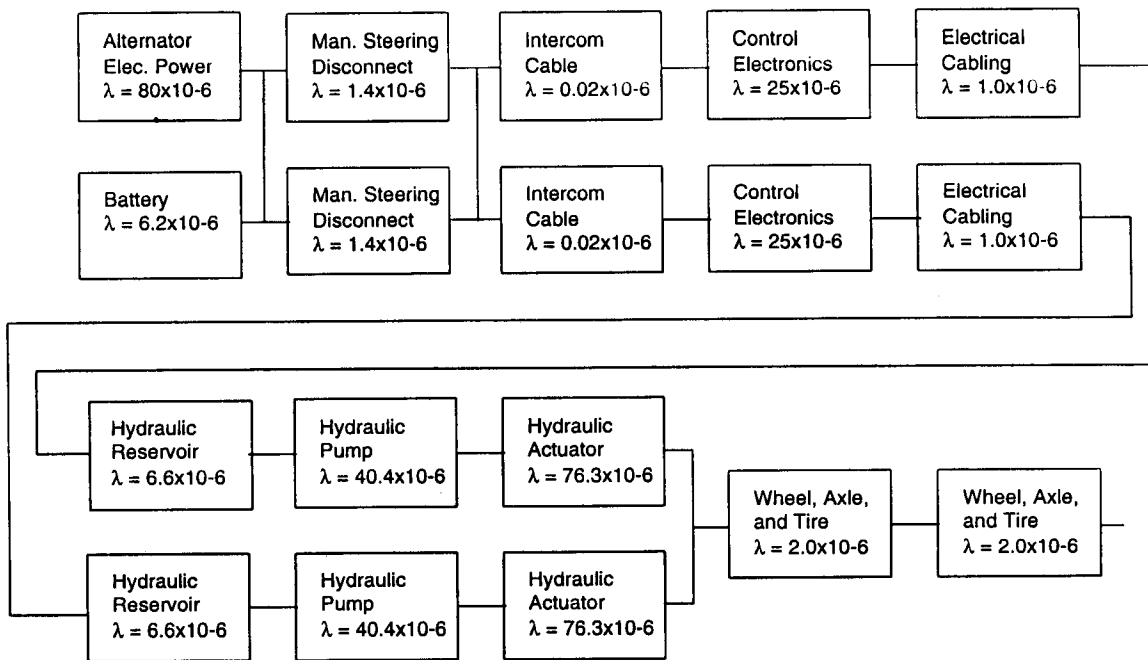

Figure 1: Dual Redundant Steering Safety Diagram Compared to Honeywell Figure 14

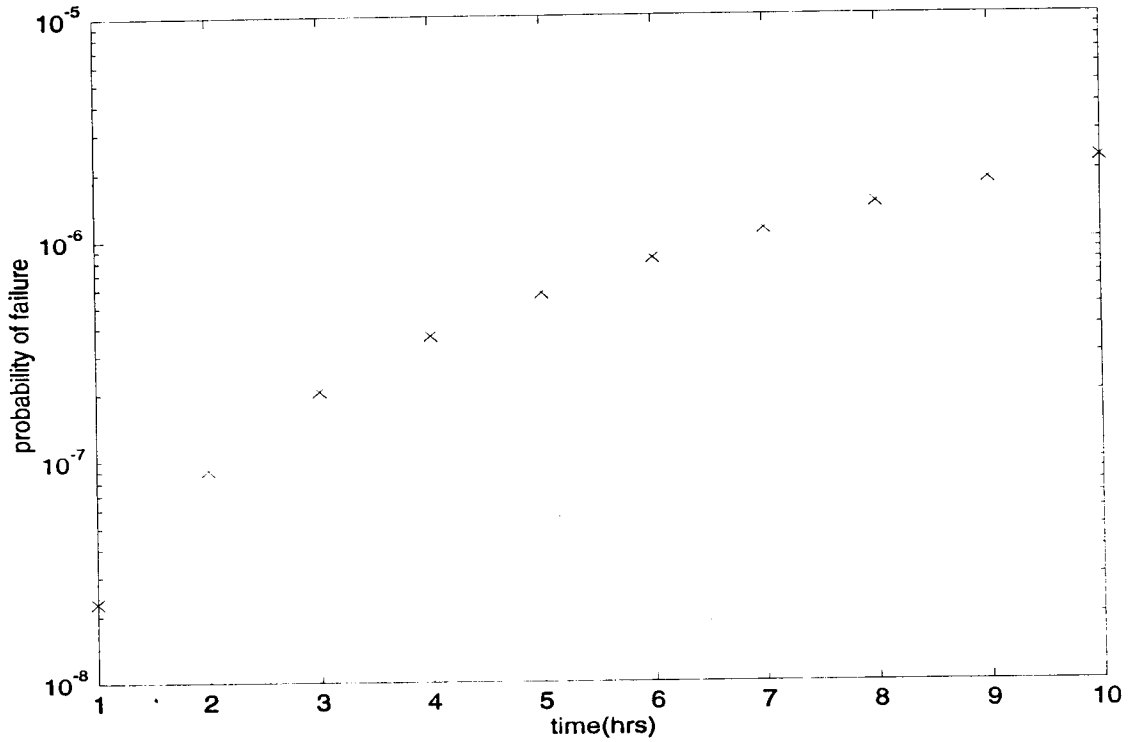
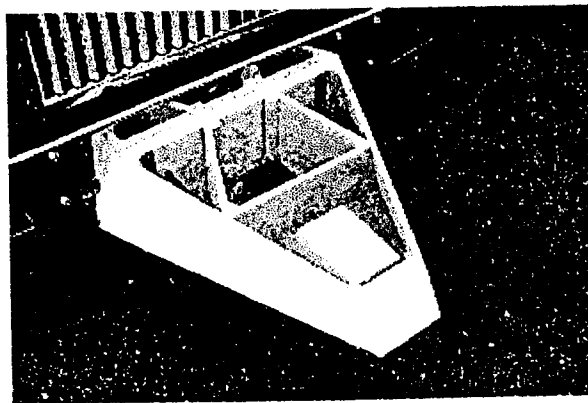
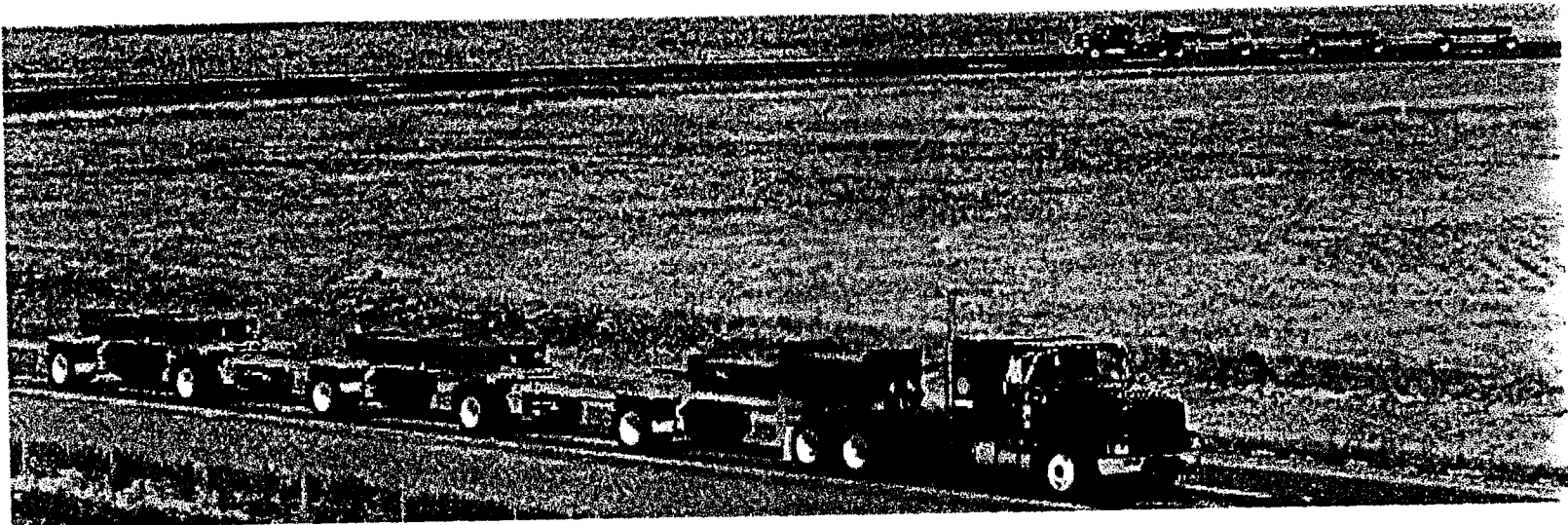

Figure 2: Probability of Failure vs. Time for Dual Redundant Steering Subsystem Compared to Honeywell Figure 15 (Different)

Table 1: Dual Redundant Steering Subsystem

Time(hrs)	Probability
1	2.2791e-08
2	9.1151e-08
3	2.0506e-07
4	3.6450e-07
5	5.6944e-07
6	8.1988e-07
7	1.1158e-06
8	1.4571e-06
9	1.8439e-06
10	2.2761e-06

Westrack



Conclusions

- Designing from first principles to produce an architecture to tolerate failures achieves better reliability, availability, and cost-effectiveness
- Historically, goals of 100% unattainable for:
 - Fault detection/isolation
 - Availability
 - Design correctness

Comments:

- Large open problem
 - Sojourner problems
 - WesTrack problems (without computers!)

Recommendations 8:

- Watch developments in fault-tolerant systems
- Include reliability at first stage of designs

Problem 9: Miscellaneous Problems

- Actuators
- Driver condition
- Traffic condition sensing
- Infrastructure processing
- Check-in and merging algorithms
- Obstacle avoidance algorithms
- Exit management algorithms

More Misc. Problems

- TMC algorithms
- Traffic operations and maintenance
- Roadway design
- AHS-specific construction
- AHS-specific maintenance and rescue vehicles

Radar EMC/EMI

Detailed Description of Task:

Considering mass production and application of radars on vehicles, the electromagnetic compatibility, and especially, electromagnetic interference issues can become major obstacles in using this technology. The main goal of this RFP is to address the relevant issues of radar EMC/EMI. In particular, the objective is to answer the following questions:

1. What are the effects of low average power (10-100mW) CW or pulsed radar energy transmission at frequency > 20 Ghz, or lower frequency IF on various electronic components of
 - i) the vehicle with the radar?
 - ii) other vehicles?

2. What are the effects of different vehicle electronic components (e.g., an RF transmitting unit with fair amount of power, GPS, ...) on the radars and their signal integrity, false alarm rate or sensitivity?

3. In a multi-radar environment, what are the antenna main beam-to-main beam, main beam-to-sidelobe and sidelobe-to-sidelobe effects of mutual interference on radar performance?

Radar EMC/EMI

4. What are the environmental radiation sources which may possibly affect the radar (high power electric lines, military zones, etc.) and what are these effects?
5. What are other relevant issues, if any?
6. How, and to what degree, can we mitigate items 1-5 through radar design (e.g., antenna design, waveform selection, low sidelobes, signal processing) or by other means?

The solutions to the above problems are to be supported by appropriate testing or sound, verifiable simulation analysis. Although, we favor a proposal covering all of the above listed questions, others, addressing a partial list, will be evaluated as well.

Comments: and Recommendations 9:

- Driver Condition is a major problem
- Most others are more design-specific

Problem 10: Cluttered Environment

- Subproblems:
 - stopped vehicles
 - obstacles
 - radar side lobes
 - overpasses
- Possible Solutions:
 - Sensor Friendly Roadway

NAHSC Activities:

- Clutter can be:
 - moved
 - masked (RAM)
 - marked (MEMS?)
 - recognized
- Impacts infrastructure and maps and sensors

SFR SOW

- Characterize Targets and Backgrounds
 - Geometrics, Surface Properties, Temporal (Diurnal and Transient) Variations, Weather Variations
- Analyze and Specify Sensing Systems
 - MMW Radar, NIR Laser, Imaging
- Determine Draft CVHS Specifications
- Provide Comprehensive “CVHS Design Guidelines” Document
- Generate Sensor-Friendly Roadways, Phase II SOW

Facilitate Object/Obstacle Detection



- On tangent highway alignment the location of objects are visible.
- On curving highway alignments the location of objects that might normally be visible to the human eye, are not visible to fixed forward looking radar
- The cooperative system can be designed to handle this scenario.
 - If an omni-directional radar is used, rather than fixed radar, then although the object may be seen, its location in relation to the lane is not known.
 - If a form of *road preview* could be utilized in addition to the omni-directional radar, then the relationship between the object and location of the lane could be known and the determination made whether it is:
 - a roadside object, a vehicle in adjacent lane
 - a potentially dangerous obstacle to be avoided.

Road Preview



- To distinguish objects from roadside environment the vehicle must know its position in relationship to the road in real time.
- The highway alignment information, or "*Road Preview*", could be provided by:
 - communication from the infrastructure in a cooperative system
 - a "*map*" in the autonomous system.
- In a cooperative system the information could come from
 - encoding magnetic markers,
 - magnetic stripes,
 - radar reflective stripes,
 - wireless communications

6

Type of Infrastructure Objects found in Roadway Environment



- Standard roadway objects that make obstacle recognition more difficult and may contribute to false alarms:
 - electroliers
 - signs and sign posts
 - bridges/abutments/expansion joints
 - guardrail (metal)
 - guardrail (concrete)
 - pavement reinforcing steel
 - highway markers (i.e.. postmile and culvert markers)

10

Masking



- **Diminish reflectivity to the point where effectively it can be assumed to be masked**
 - Use materials which are not good radar reflectors
 - Reduce or eliminate use of highly reflective materials such as steel
 - Use new construction materials called composites that have low radar reflectivity:
 - Plastic reinforcing bars to replace steel rebar in concrete
 - Electroliers/new poles made of fiberglass reinforced plastics (FRP) to replace metal poles.
 - bridge decks of composite materials to replace steel and concrete bridges.
 - Sign posts and sign fabric- use composites to replace steel

12

Alternative Construction Materials



- **Plastic Reinforcing Bars**
 - plastic reinforcing bars (composite materials) are relatively new.
 - Some composite reinforcing bars offer considerable strength advantage over conventional rebar, and thus in some instances fewer rebar may be required.
 - Current drawback is cost, composite bars slightly more expensive, but with increased production may reverse this.
 - AASHTO does not have established standards for composite structures.
 - Not all states have design manuals that advocate or even allow use of plastic reinforcing bars as an alternative or replacement for conventional steel rebar.

13



Alternative Construction Materials

- **Electroliers/ New utility poles coming on the market which are non-metallic.**
 - Made of fiberglass reinforced plastics (FRP)
 - Emergence is primarily due to need for materials that reduce roadside maintenance.
 - The life of plastic poles is expected to be greater than steel poles

- **Sign Posts and Sign Fabric**
 - Useful life and maintenance can be improved with the use of composites.
 - Sign fabric which is typically sheet steel can represent a large target for radar. A composite sign fabric would significantly reduce this reflected target or potential object.

14



Targeting (tagging) of Roadside Items

Radar Reflectors

- **Omni-directional vs corner reflector.**
 - With multiple radar sources best to minimize interference by sending image back along incident path.
 - a corner reflector could provide coverage of about 30 degrees which for usual highway alignment should be adequate.
- **Corner reflector type appears best suited**
 - Corner reflector is 3 plane reflector
 - probable size for highway application is 8-12 inches
 - Cost range is \$250-\$300 each
 - Could be customized with other materials to drop below \$200 per reflector

15

How to Create Radar Sensor Friendly Highway



- **New Construction**
 - The most practical time to incorporate masking of roadway items is when a roadway is being designed and constructed.
 - By including the new materials in the design plans, construction costs can be minimized.

- **Existing Infrastructure**
 - Difficult to retrofit with new materials, particularly where much of the steel is already in columns, bridges or concrete barrier rails.
 - The infrastructure lends itself to being tagged or marked with radar reflectors.

17

SUMMARY



- Overall the technology for supporting radar cooperative sensor friendly highway looks promising. However there are still several areas which need further research.

- Initial assessment of obstacle detection (without road preview) using on-board vehicle radar system indicated:
 - on-board radar sensor based control system will work on the main line highways and on the straight or gentle alignment of rural roads,
 - there will be a problem for object/obstacle detection in the driving lane on the small radius curves of rural roads and interchanges.

20

SUMMARY (continued)



- **Methods to achieve road preview need defining and development**
 - currently little work being done in this area
 - substantial concept work and development remains to be done in this area
 - highway geometric requirements and speed limitations must be incorporated

- **Field tests with sample infrastructure radar reflectors and multiple vehicle radars need to be conducted**
 - effort should be directed towards development of a standard radar reflector
 - development should be coordinated with as many interested state DOTs as feasible

21

Recommendations 10:

- Do it!
- Big benefits for IVI
- Continue work in
 - analyze problem
 - assess approaches

Wrap-Up

- Vast majority of NAHSC Technology work is applicable to IVI
- Most of it unfinished
- Much is promising
- Danger of losing momentum, data, apparatus, and people

Most Important Points

- NAHSC made significant progress
 - identifying and prioritizing problems
 - obstacle detection
 - vehicle + lane position fusion
- Significant challenges remain:
 - detecting obstacles
 - predicting braking capability
 - separating returns from clutter
 - system reliability
 - human factors

Cooperative Systems

- Cooperative systems can help:
 - reduce clutter
 - reduce obstacles
 - tag vehicles
 - mark lanes
- Cooperative systems can enhance:
 - communicate vehicle braking
 - communicate obstacle locations

Autonomous Systems

- Some functions can also be performed autonomously:
 - (some) lane sensing
 - (most) obstacle detection
 - (some) vehicle sensing
 - (some) control
- Not “Autonomous vs. cooperative”; better “Degrees of cooperation”

Appendix R



Market Packages for Cooperative Systems

Dr. Carol Jacoby
Raytheon Systems Company

Agenda



- Overview of Market Packages
- The Role of Cooperation
- Cooperative Contributions to Market Packages
- Summary

What are Market Packages?



- **Groups of user services that provide benefit by themselves**
- **Defined at the architecture level, but not implementation**
- **Packaged as a potential product or capability**
- **Provide a range of capabilities for various needs, budgets, timeframes and levels of automation**
- **Defined to support the steps in evolutionary deployment**
- **Support defined growth paths to greater capabilities**

Jacoby/market packages/4/98

3

Market Packages Provide a Range of Levels of Control



- **Warning and Advice**
 - 31 packages, 17 situations
- **Temporary Emergency Control**
 - 37 packages, 17 situations
 - Avoidance and Resistance
- **Control of Normal Driving**
 - 14 packages, 8 situations
- **Automated**
 - 3 packages, 3 situations
- **Specialized**
 - 8 packages, 8 situations

Each market package addresses a particular situation, and may be

- Autonomous or cooperative
- Warning, resistance or control

Jacoby/market packages/4/98

4

Market Package Situations: Warning or Temporary Control



- Frontal Collision Avoidance
- Curve Overspeed Avoidance
- Blind Spot Collision Avoidance
- Side Collision Avoidance
- Lane Change Collision Avoidance
- Lane Departure Avoidance
- Road Surface Condition Avoidance
- Traffic Situation Awareness
- Defensive Driving Support
- Merge Maneuver Support
- Lane change Maneuver Support
- Traffic Negotiator
- Vehicle Condition Warning
- Driver Condition Warning
- Road Management Situation Avoidance
- Intersection Collision Avoidance
- Railroad Crossing Avoidance

Most of these come in different "flavors"

- Autonomous or cooperative
- Warning, resistance or control

Jacoby/market packages/4/98

5

Market Package Services: Some Control of Normal Driving



Control of Normal Driving

- Adaptive Cruise Control
- Advanced Adaptive Cruise Control
- Lane Keeping
- ACC and Lane Keeping
- ACC, FCA, SCA
- ACC, FCA, SCA, Lane Keeping
- ACC, FCA, SCA, LK, Auto Lane Change
- ACC, FCA, SCA, LK and Merge
- All of the above

AHS

- AHS in Mixed Traffic
- AHS in Dedicated Lanes
- AHS in Mixed or Dedicated Lanes

Specialized

- Automated Bus Movement in the Maintenance Area
- Automated Snowplows
- Truck Convoy With Driver in Lead
- Truck Safety System
- Bus Docking Aid
- Automated Container Movement
- Interterminal Passenger Shuttle
- Coordinated Startup

Jacoby/market packages/4/98

6

Correspondence Between IVI and Market Packages (1/3)



IVI Services	Market Package Situations
Safety Services	
Rear End Collision Avoidance	Frontal Collision Avoidance, Adaptive Cruise Control, Advanced Adaptive Cruise Control
Road Departure Collision Avoidance	Lane Departure Avoidance, Automated Snowplow
Lane Change and Merge Collision Avoidance	Blind Spot Collision Avoidance, Side Collision Avoidance, Lane Change Collision Avoidance, Merge Maneuver Support, Lane change Maneuver Support
Intersection Collision Avoidance	Intersection Collision Avoidance
Railroad Crossing Collision Avoidance	Railroad Crossing Avoidance
Vision Enhancement	
Location-Specific Alert and Warning	Road Management Situation Avoidance
Automatic Collision Notification	
Smart Restraints and Occupant Protection	

7

Jacoby/market packages/4/98

Correspondence Between IVI and Market Packages (2/3)



IVI Services	Market Package Situations
Safety Impacting Services	
Navigation/Routing	
Real Time Traffic And Traveler Information	Road Management Situation Avoidance
Driver Comfort and Convenience	
Vehicle Stability Warning and Assistance	Curve Overspeed Avoidance
Commercial Vehicle	
Driver Condition Warning	Driver Condition Warning
Vehicle Diagnostics	Vehicle Condition Warning
Cargo Identification	
Automated Transactions	
Safety Event Recorder	

8

Jacoby/market packages/4/98

Correspondence Between IVI and Market Packages (3/3)



not so clear →

IVI Services	Market Package Situations
Transit Vehicles	
Obstacle/Pedestrian Detection	Frontal Collision Avoidance
Tight Maneuver/Precision Docking	Bus Docking Aid
Transit Passenger Monitoring	
Transit Passenger Information	
Special Vehicle	
Fully Automated Control at Certain Facilities	Automated Bus Movement in the Maintenance Area, Automated Container Movement, Interterminal Passenger Shuttle
Supporting Services	
Low Friction Warning and Control Assist	Road Surface Condition Avoidance
Longitudinal Control	Adaptive Cruise Control, Advanced Adaptive Cruise Control
Lateral Control	Lane Keeping

Jacoby/market packages/4/98

9

Market Package Situations Beyond IVI Stress Advanced Control and Situation Awareness



- ACC and Lane Keeping
- ACC, FCA, SCA
- ACC, FCA, SCA, Lane Keeping
- ACC, FCA, SCA, LK, Auto Lane Change
- ACC, FAC, SCA, LK, Merge
- ACC, FCA, SCA, LK, Auto Lane Change and Merge
- AHS in Mixed Traffic
- AHS in Dedicated Lanes
- AHS in Mixed or Dedicated Lanes
- Truck Convoy With Driver in Lead
- Truck Safety System
- Coordinated Startup
- Traffic Situation Awareness
- Unsafe Driving Situation Warning
- Traffic Negotiator

Jacoby/market packages/4/98

10

Conclusions on Market Packages



- **Built on Applications of Sensors and Computers**
- **Focus on Early Applications**
- **Address a Range of Situations**

Agenda



- **Overview of Market Packages**
- **The Role of Cooperation**
- **Cooperative Contributions to Market Packages**
- **Summary**

There are Gradations of Cooperation



- **Autonomous systems**
 - Minimal modifications to infrastructure needed
 - Completely self-contained vehicle.
- **Vehicle-roadway cooperative**
 - System benefits from some information that is not normally there
 - Protected Highway
 - Sensor-friendly Highway
 - Communications, e.g., Dynamic Speed Limits
- **Vehicle-vehicle cooperative**
 - Communications- and Sensor-Friendly Car
 - Coordinated Maneuvers
 - Platooning

Jacoby/market packages/4/98

13

Cooperation Supports Safety



- **Safety is the key requirement**
- **The driver cannot be relied on to monitor**
- **Must respond to all hazards and scenarios**
- **Vehicle must get static and dynamic information from the roadway**
- **Cooperative roads may initially be used for automation, with possible restrictions or protection**

Jacoby/market packages/4/98

14

Automated Situation Response Requires a Range of Information



- Even partially automated or warning systems may need to supplement inattentive driver
- Many situations require dynamic roadway information to respond safely, for example:
 - Officer directing traffic
 - Highway patrol in pursuit
 - Emergency vehicle
 - Closed lane
 - Construction
 - Flares
 - Roadway ends
 - Lane ends
 - Warning devices
- These are difficult to sense
- Conclusion: Extensive information available visually to the driver must go to the vehicle as well.

15

Jacoby/market packages/4/98

Agenda



- Overview of Market Packages
- The Role of Cooperation
- Cooperative Contributions to Market Packages
- Summary

16

Jacoby/market packages/4/98

What is Provided by Cooperation (1/3)?



Warnings

- Potential forward collisions at intersections and railroad crossings.
- Curve warning from other vehicles or roadway
- Surface condition information (e.g., ice)
- Driver warnings from other vehicles
- Pre-brake warnings
- Hazardous objects
- Temporary situations (construction, emergency vehicles, ...)
- Speed restrictions

Jacoby/market packages/4/98

17

What is Provided by Cooperation (2/3)?



Guidance

- Road edge markings (especially snowplows)
- Dynamic external guidance for containers or buses in maintenance
- Designated exits (interterminal passenger shuttle)

Situation Awareness

- Fusion of local situation from other vehicles or infrastructure, for broader scope
- Communication systems, to supplement or replace vehicle sensors

Jacoby/market packages/4/98

18

What is Provided by Cooperation (3/3)?



Efficiency

- State information of surrounding vehicles, for more accurate and timely collision avoidance
- Gap creation and maintenance for merge
- Infrastructure merge smoothing (smart ramp meter)
- Lane change coordination
- Dynamic speed limits
- Traffic flow control
- Platooning
- Coordinated startup

Agenda



- Overview of Market Packages
- The Role of Cooperation
- Cooperative Contributions to Market Packages
- **Summary**

Summary



-
- **Easing driver workload causes inattention, and creates a void that must be filled by cooperative information from the infrastructure and/or the surrounding vehicles**
 - **Cooperation enhances a diverse range of market packages**
 - **A small amount of cooperation often has big payoffs**
 - **93 market packages have been defined, to support various evolutionary strategies**



Deployment: How Do Progressively Advanced Systems Roll Out Over Time?

Tom McKendree

28 April 1998

1:40 pm

1

Agenda



-
- Timeline Views of Deployment
 - Deployment Strategies
 - Addressing Deployment Issues
 - “Autonomous” and “Cooperative”
 - Conclusion

2

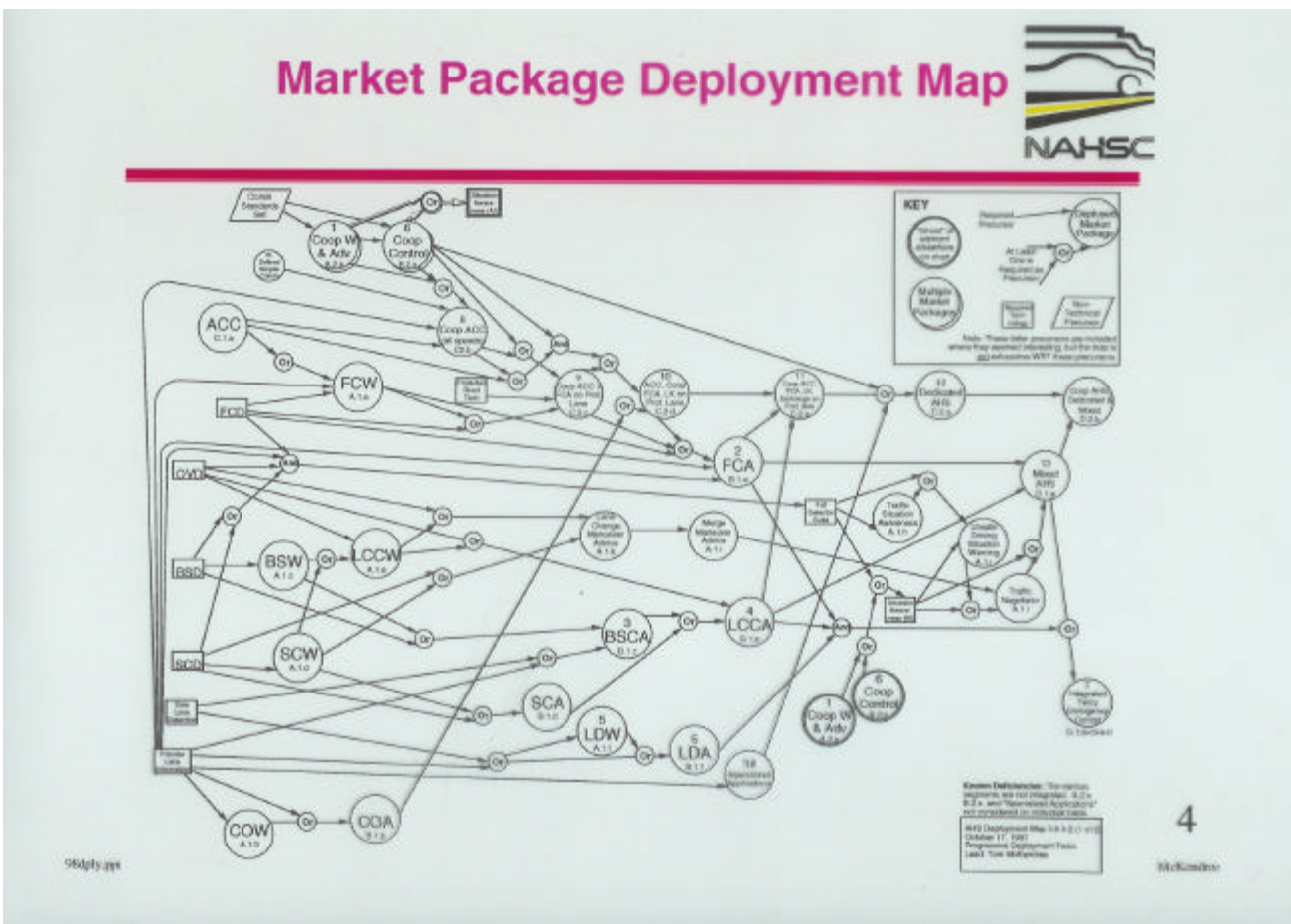
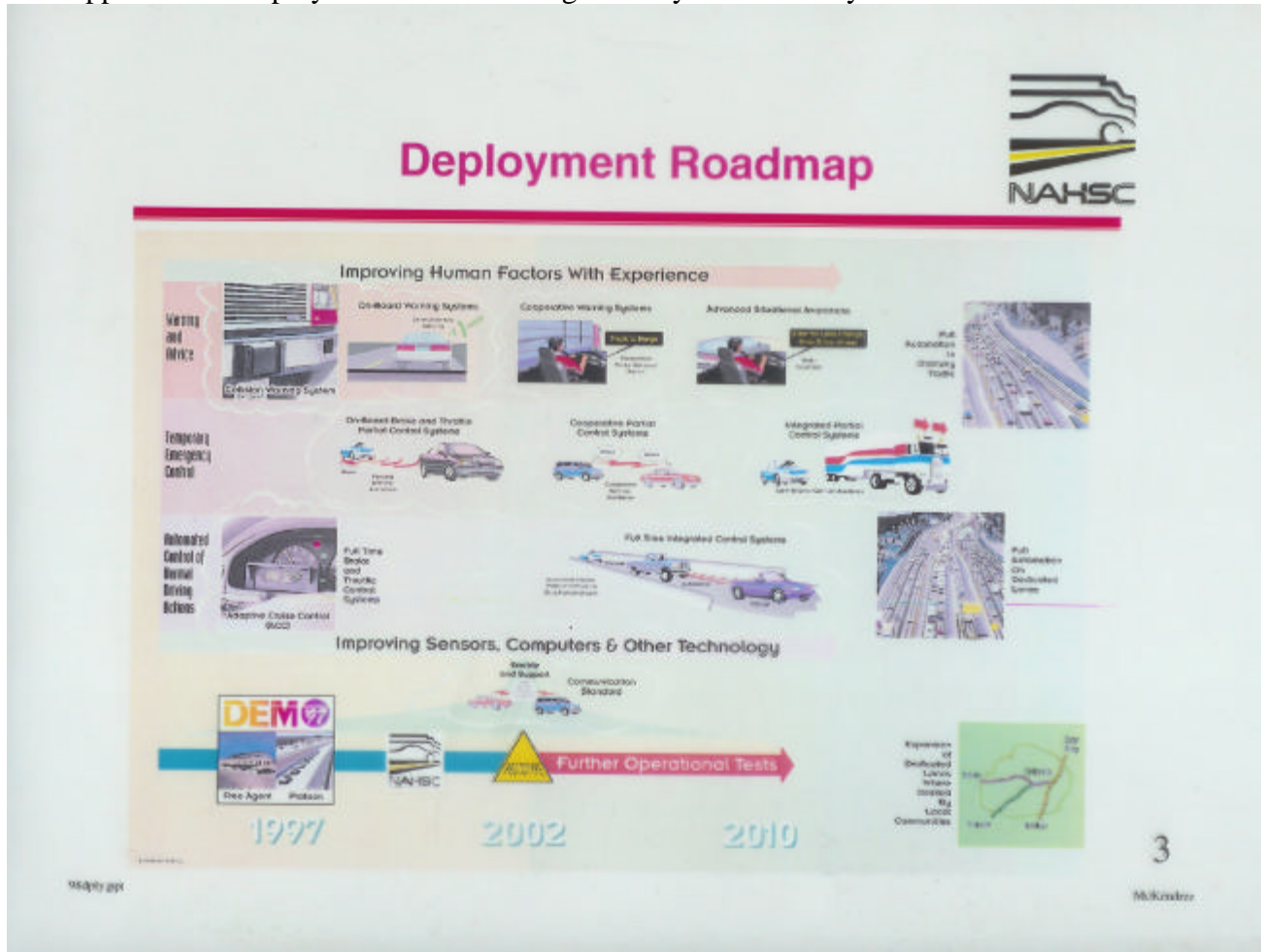

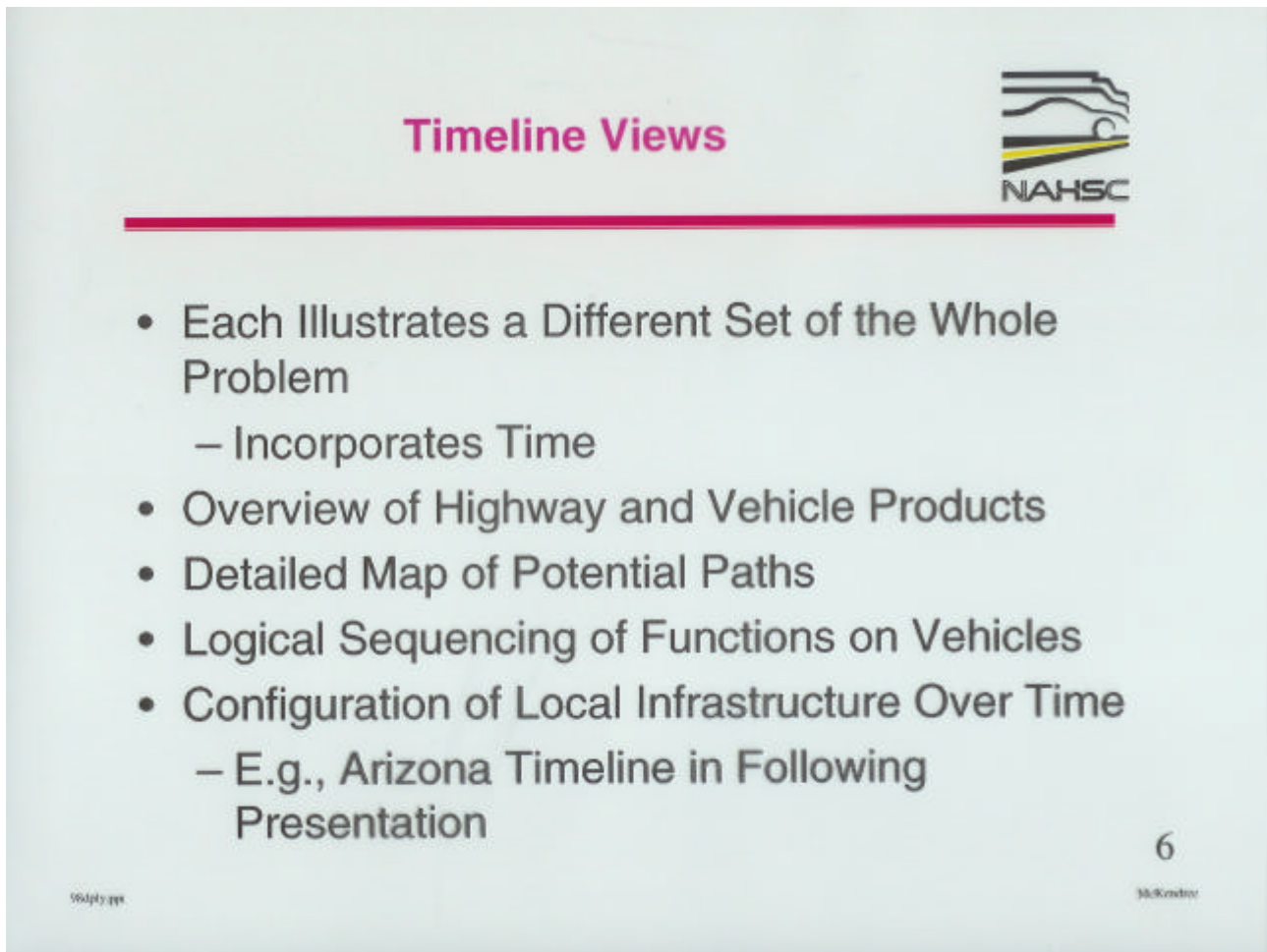
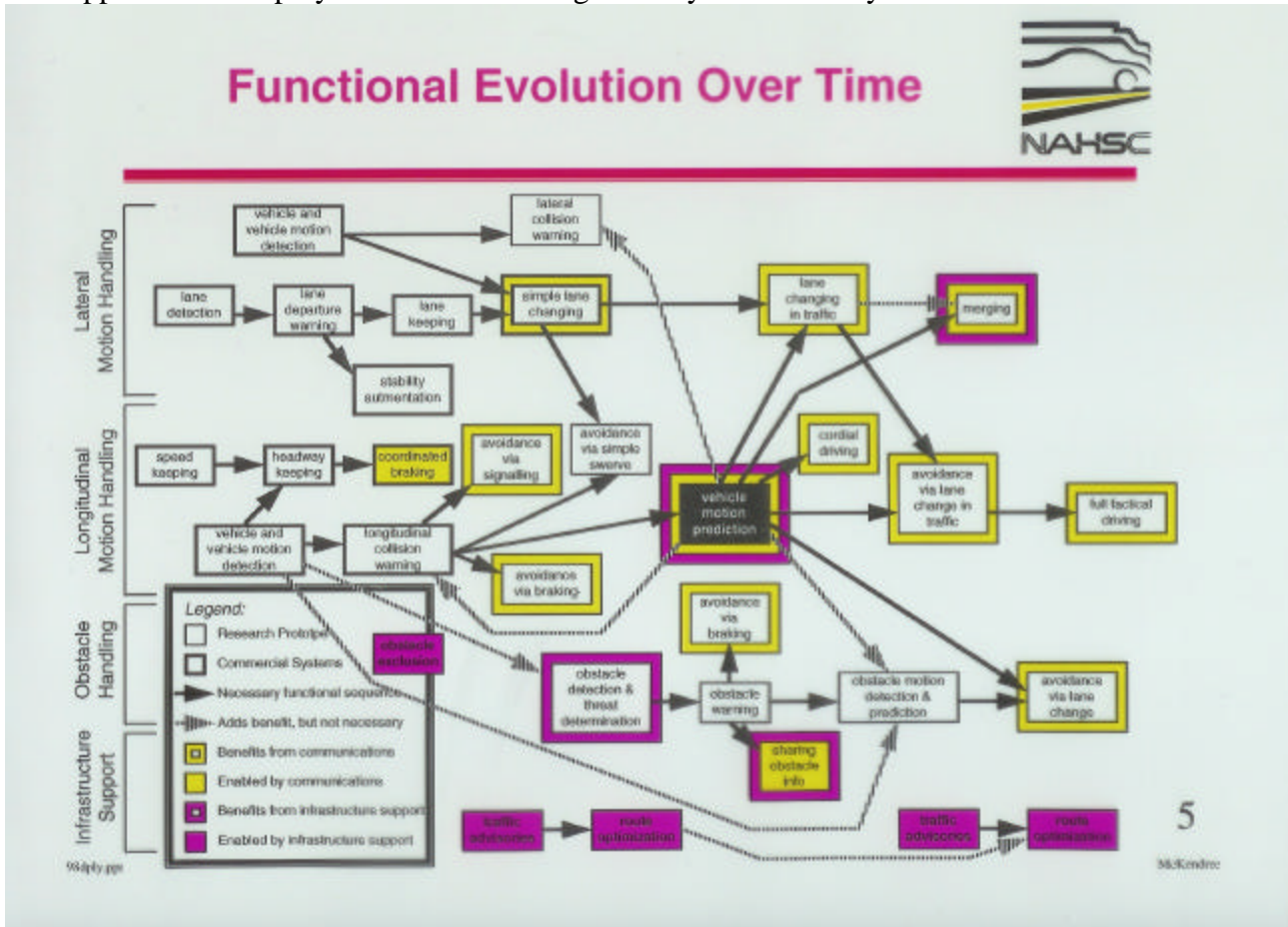

- Each Illustrates a Different Set of the Whole Problem
 - Incorporates Time
- Overview of Highway and Vehicle Products
- Detailed Map of Potential Paths
- Logical Sequencing of Functions on Vehicles
- Configuration of Local Infrastructure Over Time
 - E.g., Arizona Timeline in Following Presentation

Deployment Strategies Overview



- Identified 12 Candidate Deployment Strategies
 - Address Several Key Issues
- Will Summarize the Issues And How The Strategies Proposed to Resolve Them
- Conclude With the Characteristics of “Autonomous” and “Cooperative” Strategies

7

08/21/17 ppt

McKenzie

Strategies



- “Autonomous”
 - “Market-Driven”
 - Smooth Evolution to Mixed Traffic AHS
 - Driver-Engaged AHS Data Collection
 - Start With Driver Engaged Mixed Operations
 - Wait for Mixed Traffic AHS
 - Foreign Leadership Through Risk Taking
- “Cooperative”
 - “Policy-Driven”
 - Dedicated Lane Operational Test Showcase
 - Dedicated Lane Operational Test Seedlings
 - Dedicated as a Stepping Stone to Dual-Capable
 - “Bootstrapping”
 - Communications Policy Driven Approach on Mixed Dedicated Lanes

8

08/21/17 ppt

McKenzie

The “Chicken & Egg” Problem



- How Can AHS Lanes Be Deployed, If There Are No AHS Vehicles to Use Those Lanes?
- How Can AHS Vehicles Be Deployed, If There Are No AHS Lanes For Them to Use?



9

Other “Chicken & Egg” Problems



- How Did They Sell Cellular Phones, Without Cellular Phone Cells (Towers, etc)? How Did They Install Phone Cells, Without an Installed Customer Base of Cellular Phones?
- How Did They Sell Web Browsers Without Web Sites, or Web Sites Without Web Browsers?
- How Did They Sell Cars Without Highways?
- *Every “Chicken and Egg” Problem is a Positive Feedback Loop Waiting to be Unleashed*

10

Resolutions to the “Chicken & Egg” Problem



- Timing of Initial Components
 - Initial Use Of Pre-Existing Elements
 - New Cars on Existing Roads
 - New Roads Allowing Existing Cars
 - Integrated Introduction
- Start with Highest Marginal Value Niches
 - Trucks, Buses, Other Specialized Vehicles
 - Bridges, Tunnels, Access Roads, Etc.
- “Pump Priming”
 - Operational Test, Model Deployment

984pt.ppt

11

McKenzie

Technical Challenge Over Time and Speed of Development for Mixed Full Automation



- Clearly Not Yet Solved
 - Obstacle Detection
 - Traffic Situation Awareness
 - E.g., Automated Response to Unfolding Incident
 - Integration of Technologies
 - Etc.
- No Consensus on Planning Date
 - Strategies Generally Assume an Answer
 - Huge Driver on Strategy

984pt.ppt

12

McKenzie

Approaches To Technical Challenges of Mixed Automation



- Step With Warning & Partial Control Systems
- Sustained Research
 - Improving Technology Should Aid Eventual Solution
- Defer
 - Leverage Dedicated/Protected Lane Deployments (e.g., Arizona Plan)
- Give Up
 - Deploy Dedicated Lanes
 - Deploy Mixed Use Protected Lanes

13

9846ty ppt

McKendree

Social & Institutional Challenges to Deploying Dedicated Lanes



- Dedicated Lanes Are Significant Highway Costs
 - Similar to HOV Lane Retrofit and Construction
- Parallel System Could be Very Expensive
- Unproven Novelty for Planning Process
- Lane “Take-Away” Is Politically Unpalatable

14

9846ty ppt

McKendree

Approaches to Dedicated Lane Challenges



- Coordinated Initial Deployment
 - Uncoordinated Deployment Following Successful Initial Vehicle Deployment
- Defer
 - Build or Convert After Local Market Penetration Will Support the Lane
- Give Up
 - Wait For Mixed With Manual Capability
 - Deploy Mixed Use Protected Lanes

15

Gathering Sufficient Real Data to Automate Against All “Unusual” Events



- Premise That Full Automation Requires Addressing Extreme Outlier Cases, For Which There is Insufficient Data
 - Only Seen As a Major Issue In One Strategy
- Deploy Mixed, Non-Automated Systems With Major Sensing Components, And Gather Data Before Completing Automation Designs
 - Social & Institutional Issues Unaddressed

16

Dealing with Deployment Uncertainties



- Adapt on the Margins
- For Many Uncertainties, Specific Strategies Assumed [Different] Specific Answers
 - What is the Minimum Size for an Initial Deployment That Would Successfully Grow?
 - Relative and Absolute Timing of Capabilities
 - Required Pre-Existing Vehicles for Lane Dedication
 - Federal Funding Priorities
- Ultimate Strategy Must Merge Specific Strategies Into a Decision Tree

17

Characteristics of “Autonomous” Deployment Strategies



- All Mixed With Manual Systems
- Less Need for DOT Involvement
 - May Have Some Secondary Government Support
 - E.g., Incentives, Mandating Standards
- Generally Nearer Term Planning Horizon

18

Characteristics of “Cooperative” Deployment Strategies



- Deployment of Systems Where Decisions Cross Stakeholder Boundaries
 - Usually Included Deployment of Protected or Dedicated Lanes
- All Strategies With Government Deployment Actions
- Deployment Has More Challenging Appearance
 - Important to Develop Plausible Deployment Scenarios

19

Conclusion



- Deployment Strategy Needs to Be Driven By Underlying Facts
 - No Consensus for AHS
 - Calls For Flexible Strategy That Does Not Rule Out Options
- Sustained Research With a Long-Range Eye Towards Automation is Warranted
 - Technologies Useful for Mixed or Dedicated Automation
 - Data From Deploying Other Cooperative Highway Systems

20

✓ SSS

Appendix T



Arizona's I-10 Intelligent Express Lanes

A Concept for a Highly Cooperative Highway

Jim Lewis
April 28, 1998

AGENDA



- The Arizona Demonstrations
- The I-10 Intelligent Express Lanes Concept Study
- Arizona's Needs
- Their Initial Ideas
- The Express Lane Concept
 - Physical Description
 - Deployment Plan
- Strengths
- Challenges
- Conclusions

Demonstrations and Concept Study



Following the San Diego Demonstration, Arizona requested:

- **Brief MOVE-IT committee in October**
- **Demonstration of the PATH vehicle on Dec. 15/17, 1997**
 - Full automation on a dedicated test track identical to San Diego mini-demo
- **Demonstrated of the CMU vehicle on Jan. 21/22, 1998**
 - lane keeping, lane departure warning, ACC on I-10
- **Demos attended by state legislatures, local FHWA, local elected officials, media**
 - Funded entirely by Arizona
- **30 page Concept Study on Intelligent Express Lanes for I-10, Phoenix to Tucson**
 - Covered Phased Approach, Benefits and Deployment Issues
 - Led by BRW, included Kimley-Horn, NAHSC, Dick Bishop, John Herridge (\$30,000 study)

Arizona's I-10 Corridor Issues



- **Corridor Description**
 - ~90 mile segment of I-10, flat and straight
 - All 4 lane freeway (2 lanes each way) with 80' median
 - 30,000 total vehicles per day (today), 25% trucks
 - Only one major intermediate interchange (Casa Grande / I-8)
- **Corridor Needs**
 - Need 6 lanes by 2005, and 8 lanes by 2020, to avoid onset of congestion
 - Desire shorter trip times (safe travel at higher speeds)
 - Want to promote technical innovation (Arizona can't continue to do things the way they always have)

Arizona's Initial Vision



- **Based on what they saw in San Diego, they envisioned**
 - A new lane with barriers
 - Introduction of AHS along FHWA's 1994 3 phase plan
 - Higher speeds (75 mph speed limit now)
 - Clearly saw need for support from automobile industry
- **What they did to get the ball rolling**
 - Identify funding sources (federal and state)
 - Convince legislature that vehicle solution (an AVCSS solution) be considered (vs. a high speed rail solution)
 - Elicit our help
- **How the NAHSC helped**
 - Developed a plan to meet Arizona's needs, today and in 2020, independent of progress in vehicle automation
 - Developed a plan to leverage IVI and stimulate industry efforts
 - Developed a plan with national applicability

J. Lewis (Arizona)

4/13

The I-10 Intelligent Express Lanes Concept



- **Physical Description**
 - Pave for 2 lanes plus breakdown lanes in each direction (includes median barrier)
 - configure for single express lane with breakdown and install barrier between express lane and existing 2 lanes (the PROTECTED lane concept)
 - Public exits and entrances at ends and at Casa Grande / I-8 only (emergency entries/exits as needed)
- insert drawing of lanes here

J. Lewis (Arizona)

6

4/13

The I-10 Intelligent Express Lanes Concept



- **5 Phase Deployment Plan**
 - Phase 1 - build and operate with normal vehicles
 - Phase 2 - allow field operational test vehicles to share use of lane with normal vehicles
 - Phase 3 - increase automated fleet (market penetration of AVCSS equipment)
 - Phase 4 - restrict (dedicate) the lane to equipped vehicles only, based on sufficient market penetration (e.g., only ACC vehicles)
 - Phase 5 - fully automated dedicated lane

insert 4 phase schedule here

Strengths of the Concept



- Meets traffic demand without reliance on specific AVCSS timetable, because initial operation is mixed traffic, not dedicated
- Uses single protected lane to reduce technical/liability risks of mixed traffic operations
 - AVCSS systems only have to avoid the vehicle ahead, stopping is always a safe response
 - Inability of any system to handle all sudden lane changes, low probability of lane change / merge crashes
- Can convert to normal 4 lane freeway in 2020 if technologies (or developers) fail to deliver in time
- Smoother traffic flow decreases emissions (all vehicles travel at same speed)
- Driver is safer (even at higher speeds) and more comfortable in a protected lane? -- needs research

Challenges of the Concept



- **All vehicles must travel at same speed, can this be made comfortable, desirable and enforceable?**
 - Promote lane as a high speed lane
 - HOV lanes tend to work this way
 - ACC will be a big help
- **Why will drivers equip their vehicles with anything?**
 - Added inducement of access to Phoenix HOV lanes as an inducement
- **How can fleets of vehicles be enticed to install technology?**
 - Added inducement of Incentives for truck fleets
- **Will vehicle manufacturers (or anyone else) build for this limited market?**
 - Public / Private operational tests
 - Develop suppliers of after market products
 - Build similar express lanes elsewhere

Can you really promote it against passing & cut-ins w/ 2 lanes paved?

CONCLUSIONS



- **The corridor is very attractive**
 - Timely need to increase capacity
 - Can do something before congestion is a problem
 - Construction costs are relatively low
 - Many similar corridors
- **The tough decision does not come until 2020**
 - Capacity of a single lane is increased
 - AVCSS can work in two lanes
 - Rip out barriers for 4 lanes each way
- **Encourages, but is not dependent on, AVCSS development**
 - Benefits today's drivers with no AVCSS
 - Critical infrastructure support for most forms of AVCSS
 - May even be fully automated, in my lifetime