

Truck CACC System Design and DSRC Messages

**PATH Research Report for
FHWA Exploratory Advanced Research Program
Cooperative Agreement DTFH61-13-H00012**

Task 2.1 – Design CACC Control System for the Trucks

Xiao-Yun Lu and Steven Shladover

February 2018

Table of Contents

1	Introduction	4
2	Control System Design for Integrated ACC and CACC	4
	2.1 Overall System Structure.....	4
	2.2 Vehicle Kinematics and Upper Level Control.....	6
	2.3 Feedforward Part for CC	7
	2.4 Feedforward Part for ACC	8
	2.5 Feedforward Part for CACC.....	9
3	Control System Modeling Structure and Implementation	10
	3.1 Control System Modeling Structure.....	10
	3.2 Upper Level Control Implementation Logics	11
	3.3 Logic for Transitions between Scenarios	13
	3.4 Logic for Fault Detection and Handling.....	14
	3.5 Lower Level Control	16
	3.6 Stability and String Stability.....	17
4	DSRC Communication Messages among Trucks	18
	4.1 DSRC for CACC/Platooning.....	18
	4.2 Data for Control and Active Safety.....	19
	4.3 Data for Coordination of Maneuvers within Platoon	22
	4.4 Data for Fault Detection and Handling	23
	4.5 Data for coordination between Platoons.....	24
	4.6 Concluding Remarks	25
5	References	26
6	Appendix: Integrated ACC and CACC Development for Heavy-Duty Truck Partial Automation	
	27	

List of Figures

Figure 2-1. Overall structure of the control system	5
Figure 2-2 Overall control logic structure	5
Figure 2-3. DSRC communications among trucks.	6
Figure 2-4 Progressive coupling with front vehicle based on clearance distance (D-Gap).....	8
Figure 3-1. Truck CACC Control System Modeling.....	11
Figure 3-2 Control Logic for Vehicle 1 in CC and ACC modes	12
Figure 3-3 Feedforward Control for CACC vehicle $I > 1$	13
Figure 3-4. Logic for transitions among 3 driving modes: manual, ACC and CACC	14
Figure 3-5. Preliminary fault detection and handling for truck CACC system	14

List of Tables

Table 4.1. DSRC Messages list for control and Active Safety purpose	20
Table 4.2. Message list for the coordination of maneuvers with a CACC string/platoon	23
Table 4.3 DSRC messages for CACC string/platooning fault detection and management....	24
Table 4.4 DSRC message list for the coordination between CACC strings/platoons	25

1 Introduction

This report documents the modeling, control design and implementation logic of the CACC (Cooperative Adaptive Cruise Control). Intuitively, CACC is based on ACC by adding intervehicle communication. This does not mean that CACC control design is simply adopting ACC control design with DSRC passed information from the forward vehicle(s). The deep reason is that: ACC control does not need to consider string stability in multi-vehicle following since it is for a single vehicle. It is fine as long as the feedback control is robustly stable with respect to all the disturbances from the external environment. CACC, on the other hand, needs to consider the *string stability* [5] (also see the Appendix) of all the vehicles in the string beside the feedback stability of the subject vehicle itself.

For simplicity, the overall control design is divided into upper level control and lower level control. The former is to select the desired acceleration/deceleration based on speed and distance tracking errors – the difference between the desired value and the sensor measured value. The latter is from the desired acceleration/deceleration to desired engine torque. The upper level control is based on linear kinematics and lower level control is based on nonlinear powertrain and drivetrain models.

2 Control System Design for Integrated ACC and CACC

This section describes the overall structure of the CACC system, which includes: central control computers, Laptop computers for development, DVI (driver vehicle interface), sensors, DSRC (dedicated-short-range-communication), J-1939 data buses, and GPS (Global Positioning System) receiver. The CACC algorithm resides in the PC-104 central control computer running as one of many processes.

2.1 Overall System Structure

Figure 2-1 shows the main components of the overall control systems. The primary component is the PC-104 computer. It interfaces with J1939 Bus to read all the vehicle data and send back control commands including engine torque control, engine retarder control, and service brake control. It also runs the drivers for interfacing with other components such as the Tablet computer for Driver Vehicle Interface (DVI), 5 Hz GPS with WAAS correction, DSRC radio for vehicle-to-vehicle communications, and Volvo XPC box which is responsible for fusing the Doppler radar and video camera data for front target detection and tracking. A laptop computer is linked with the PC-104 computer for convenient development purposes since the latter does not have a user interface.

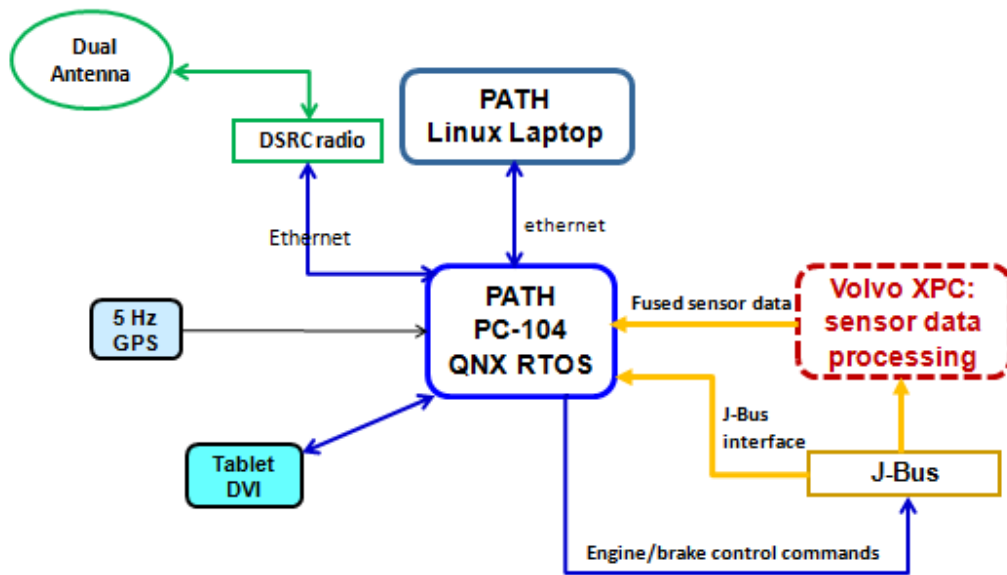

Figure 2-1. Overall structure of the control system

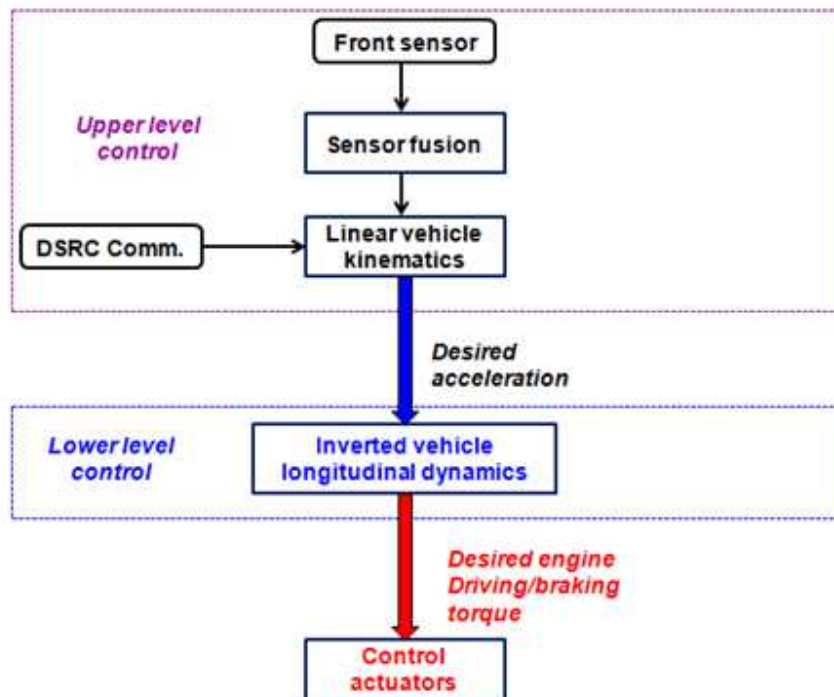

Figure 2-2 Overall control logic structure

Figure 2-2 is the control logic structure for all the feedback controllers: CC, ACC and CACC. The upper level control generates desired acceleration and deceleration based on the kinematic model which is linear. The lower level control is to convert the desired acceleration and deceleration to engine and brake control commands based on vehicle driveline dynamics.

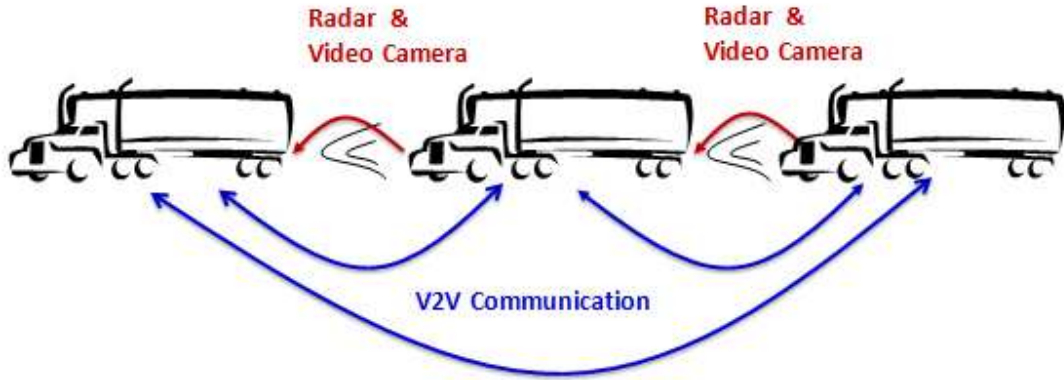

Figure 2-3. DSRC communications among trucks.

Figure 2-3 depicts the DSRC communication among the three trucks. It is a broadcast communication system in which all trucks transmit messages and can listen to the messages sent by the other trucks – each truck will receive the data packets from the other two trucks at the frequency of 10 Hz. The definition of the packet will be described in detail in the latter part of this report.

2.2 Vehicle Kinematics and Upper Level Control

The model for upper level control is based on a simple linear second order kinematic model. The feedback control for upper level control is integrated in the following sense: CC, ACC and CACC share the same feedback control structure of (Eq. 2-1). The feedforward parts for CC, ACC and CACC are designed according to the control objectives.

$$\begin{aligned}
 \ddot{\mathcal{E}}_i(t) + k_{i,1}\dot{\mathcal{E}}_i(t) + k_{i,2}\mathcal{E}_i(t) &= 0 \\
 \mathcal{E}_i(t) &= x_i(t) - x_{ref}(t) \\
 \dot{\mathcal{E}}_i(t) &= v_i(t) - v_{ref}(t) \\
 \ddot{\mathcal{E}}_i(t) &= a_{i,des}(t) - a_{ref}(t)
 \end{aligned}
 \tag{Eq. 2-1}$$

$x(t)$ – distance w. r. t. an inertia coordinate system

$v(t)$ – speed w. r. t. the inertia coordinate system

$a(t)$ – acceleration w. r. t. the inertia coordinate system

$x_{pre}(t)$ – relative distance to the preceding vehicle

$v_{pre}(t)$ – preceding vehicle speed measure

$a_{pre}(t)$ – preceding vehicle acceleration measured

$(x_{ref}(t), v_{ref}(t), a_{ref}(t))$ – reference distance, speed and acceleration for control w. r. t. an inertia coordinate system

$(k_{i,1}, k_{i,2})$ – are coefficients to be determined in control design in the following characteristic polynomial (Eq. 2-2).

The coefficients are chosen such that the following characteristic polynomials are Hurwitz for $i = 1, \dots, N$ where N is the number of vehicles in the platoon or string:

$$H(s) = s^2 + (k_{i,1} + (i-1)k_{i,2}T_g)s + k_{i,2} \quad (\text{Eq. 2-2})$$

Besides, the two eigenvalues are purposely chosen as real negative $(-\lambda_{i,1}, -\lambda_{i,2})$ such that

$$\begin{aligned} k_{i,2} &= \lambda_{i,1} \cdot \lambda_{i,2} \\ k_{i,1} &= -(\lambda_{i,1} + \lambda_{i,2}) \\ \lambda_{i,1} &> \lambda_{i,2} > 0 \end{aligned} \quad (\text{Eq. 2-3})$$

The main task for upper level control of CC, ACC and CACC is to design the feedforward part, i.e., the reference trajectories for the subject vehicle. With such control gain choice, the analysis in [5] (also see the Appendix) proved that: (a) the feedback control on each vehicle is robustly stable; and (b) the overall system is *ultimately bounded string stable*.

2.3 Feedforward Part for CC

The leader vehicle in a CC string has two driving modes in public traffic: in *CC (Cruise Control)* when there is no other vehicle in forward sensor range; and *ACC* (following a manually driven or non-connected vehicle). The feedforward control for those two modes is different. In CC mode

$$\begin{aligned} \dot{x}_{ref}(t) &= v_{ref}(t) \\ \dot{v}_{ref}(t) &= a_{ref}(t) \end{aligned} \quad (\text{Eq. 2-4})$$

In this case, one can generate a continuously differentiable reference speed trajectory $v_{ref}(t)$ to satisfy those conditions. For CC, since there is no front target, the choice of $v_{ref}(t)$ will make speed error and distance error compatible in the following sense:

$$\begin{aligned}\dot{x}_e &= v_e \\ \dot{v}_e &= a_e = a - a_{des}\end{aligned}\quad (\text{Eq. 2-5})$$

It is clear that the smoothness of the feedback control is guaranteed if the reference trajectory is continuously differentiable (with continuous acceleration and deceleration).

2.4 Feedforward Part for ACC

For ACC, the interaction between the leader of the CACC string and other traffic must be handled correctly for the following purposes:

- (a) different driver behavior of the front vehicle
- (b) safety in vehicle following to avoid collision
- (c) to avoid over-conservativeness, which would otherwise affect the overall traffic performance
- (c) CACC string stability to be guaranteed
- (d) driver's comfort, avoiding excessive accelerations and jerks..

For those objectives, a *progressive coupling* approach is proposed (progressively approaching the front target) for the design of $v_{ref}(t)$.

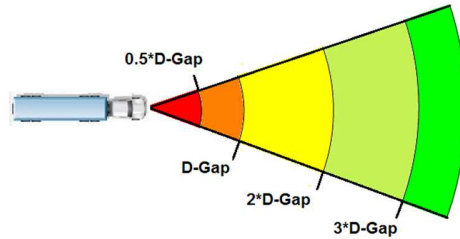

Figure 2-4 Progressive coupling with front vehicle based on clearance distance (D-Gap)

The above Figure 2-4 shows how a subject vehicle in ACC mode should be progressively coupling with its forward vehicle.

Once the forward vehicle falls into the D-Gap range (orange in Figure 2-4, the following reference trajectory will be used for fully coupling or following.

$$\begin{aligned}x_{ref} &= T_{gap} v \\ v_{ref} &= v_{pre} \\ a_{ref} &= a_{pre}\end{aligned}\quad (\text{Eq. 2-6})$$

where T_{gap} – Time Gap (T-Gap) selected by the driver; v_{pre} is preceding vehicle speed; and a_{pre} is preceding vehicle acceleration.

Once the front vehicle is outside of the Distance Gap (D-Gap), the progressive coupling approach is used by defining the reference trajectory for the different distance ranges in as follows:

$$v_{ref}(t) = \begin{cases} V_{max}, & D(t) \geq 3D_{gap} \\ \max\{V_{min,1}, V_{max} - \beta_2(v(t) - v_{pre}(t))\}, & 2D_{gap} \leq D(t) < 3D_{gap} \\ \max\{V_{min,2}, V_{max} - \beta_1(v(t) - v_{pre}(t))\}, & D_{gap} \leq D(t) < 2D_{gap} \end{cases}$$

$$D_{gap} = v(t) \cdot T_{gap} \quad (\text{Eq. 2-7})$$

$$\beta_1 > \beta_2 > 0$$

Where $D(t)$ is the measured distance; $v(t)$ is measured vehicle speed; (β_1, β_2) are control gain which are positive constant design parameters; D_{gap} is the desired distance gap; T_{gap} is the T-Gap selected by the driver; V_{max} – the maximum speed; $V_{min,1} = 25$, $V_{min,2} = 15$ are empirical numbers for the Volvo VNL trucks, which may be other numbers for other trucks. The algorithm can be explained as:

- If the target distance is outside $3D_{gap}$, the subject vehicle still uses traditional CC
- If the target distance is within the range between $2D_{gap}$ and $3D_{gap}$, the subject vehicle still uses CC with reduced speed; the reduction is proportional to the relative speed;
- If the target distance is within the range between D_{gap} and $2D_{gap}$, the reduction gain β_1 will be larger for more cautious approaching;

Other vehicles cutting in front of the subject vehicle from an adjacent lane or from an onramp is an important scenario to handle. The cut-in vehicle may have (a) similar speed; (b) higher speed; or (c) lower speed compared to the subject vehicle. The cut-in vehicle may cut out for lane change or to exit through off-ramp. The subject vehicle may need to catch up with the front vehicle in those cases.

2.5 Feedforward Part for CACC

The reference state trajectory for each scenario is different, which will become clear in the following discussions.

For $i = 2$ (vehicle 2): In this case, leader vehicle speed and acceleration are passed through wireless communication directly, which are used for control. Therefore, the delay in the leader

vehicle speed and acceleration can be ignored. Since the distance measurement is still based on remote sensor sources such as radar and lidar, the delay appears in the distance error.

For $i > 2$: In this case, the subject vehicle needs to follow both the forward (immediately preceding) vehicle and the leader vehicle. A combined speeds (accelerations) of the leader and the front vehicles and the relative distance to the front vehicle are used in the control.

3 Control System Modeling Structure and Implementation

This section documents the CACC system design. The CACC implemented on the trucks is model-based which is the following sense: the upper level control is based on vehicle kinematics which is linear dynamics, the lower level control is based on the full model of powertrain and drivetrain. The upper/lower level control will be defined later when we come to the point. These control system modeling and design strategy have been used at PATH over twenty years for almost all road vehicle types: full size car, SUV, transit buses and heavy-duty class 8 trucks, and it has been proven to be very effective.

3.1 Control System Modeling Structure

Figure 3-1 depicts the overall schematic of the powertrain and driveline (upper part) with respect to the feedback control system. It is noted that the Volvo trucks used for CACC in this project do not have torque converter nor transmission retarder. The transmission is an electronically actuated traditional 12-gear shifting instead of a more traditional automatic transmission with fluid coupling. Therefore, the drivetrain is quite different from the Freightliner PATH used before, which had a traditional automatic transmission by Allison, including torque converter and transmission retarder [8].

Volvo Truck Modeling & Control System Structure

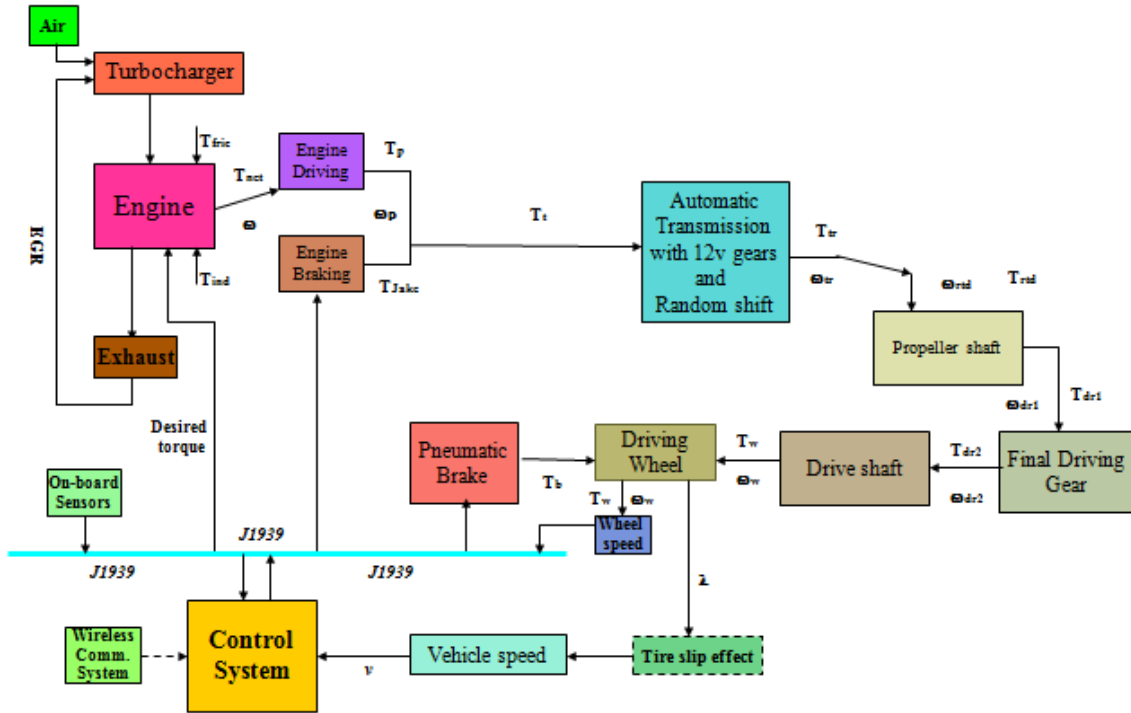

Figure 3-1. Truck CACC Control System Modeling

3.2 Upper Level Control Implementation Logics

The following Figure 3-2 depicts the feedforward control logic for handling those scenarios for CC and ACC of the leader vehicle in a CACC string.

Figure 3.2 shows the control logic and data flows for the leader vehicle in public traffic. The handling of cut-in and cut-out scenarios in the public traffic is important because it affects the overall performance of the CACC string. Cut-in and cut-out are mainly sudden changes of the front target distance but not solely. For example, if there is a second cut-in (cut-out) in front of the first cut-in vehicle, the distance to the immediately preceding cut-in vehicle will change gradually instead of suddenly. The time step between step k and step $k-1$ for control update is 20 ms, representing a 50 Hz update rate. In this scenario, the control mode changes could be one of the following:

- CC \rightarrow ACC due to cut-in
- ACC continuing with distance changes (increase/decrease corresponding to cut-in/cut-out)
- ACC \rightarrow CC due to cut-out of all the forward vehicles in sensor range

In all situations, the feedback control of ACC should be able to accommodate such changes to keep the feedback control stable since it is globally exponentially ultimately bounded stable [5] (also see Appendix).

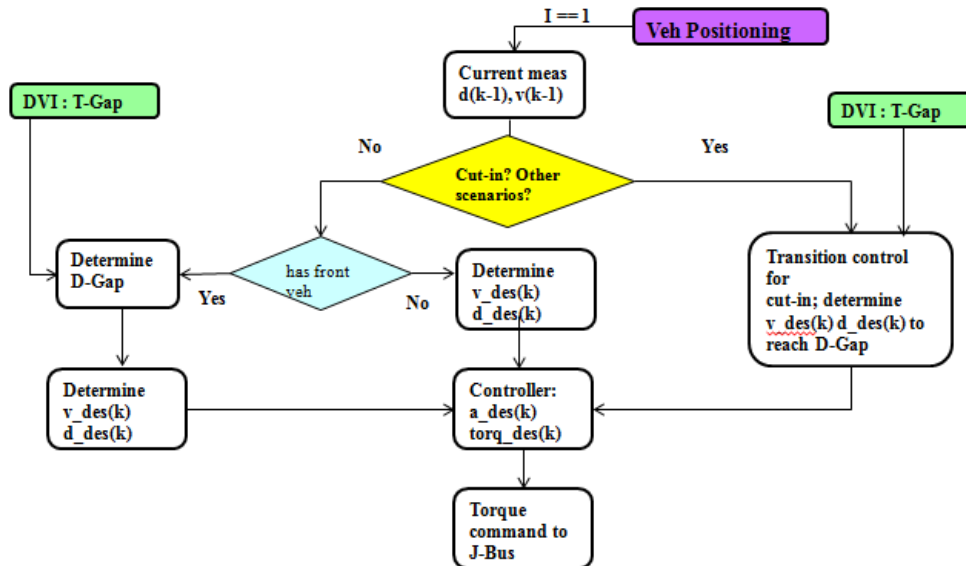

Figure 3-2 Control Logic for Vehicle 1 in CC and ACC modes

Figure 3-3 shows the logic for the CACC followers, including handling the cut-in and cut-out maneuvers. As in the previous discussion of the leader vehicle, cut-in and cut-out are mainly sudden changes of the forward target distance. For example, if there is a second cut-in (cut-out) in front of the first cut-in vehicle, the distance to the immediately forward cut-in vehicle will change gradually instead of suddenly. In principle, if there is at least one cut-in between the subject vehicle and the former forward CACC vehicle, the subject vehicle should switch gradually from CACC mode to ACC mode with a proper ACC T-Gap. A 15 s threshold is used before such a switching process, which means that the subject vehicle will stay in CACC mode with longer T-Gap for 15 s which has been determined empirically through practical tests. If the cut-in vehicle still stays in between, the subject vehicle will switch to ACC mode and become the new leader of a CACC string with reduced length. The feedback control of CACC should be able to accommodate such changes since it is globally exponentially stable, and the overall system is globally exponentially ultimately bounded [5] (also see Appendix). It could be that the cut-in vehicle will stay in between for a long time. However, the most probable situations are that the cut-in vehicle(s) will leave at the next off-ramp. Then it is necessary to check regularly if all the cut-in vehicle(s) have cut-out. If this is the case, the subject vehicle needs to join the former forward CACC vehicle to resume the previous CACC string. If it is just a single vehicle cut in, the radar should be able to detect its cut-out. However, if there are more than one vehicle cut in, the subject vehicle would not know how many vehicles are actually between the subject vehicle and the front ACC/CACC vehicle of the string.

Therefore, after the immediate front cut-in vehicle has cut-out, the subject vehicle does not know if there is still other cut-in vehicle in the front without a ground truth. To detect such a full cut-out (or partially cut-out) situation, a ground truth distance measurement is needed, which could be the GPS distance between the two trucks. This distance can be estimated by using the GPS position estimates passed among all the vehicles in the CACC string.

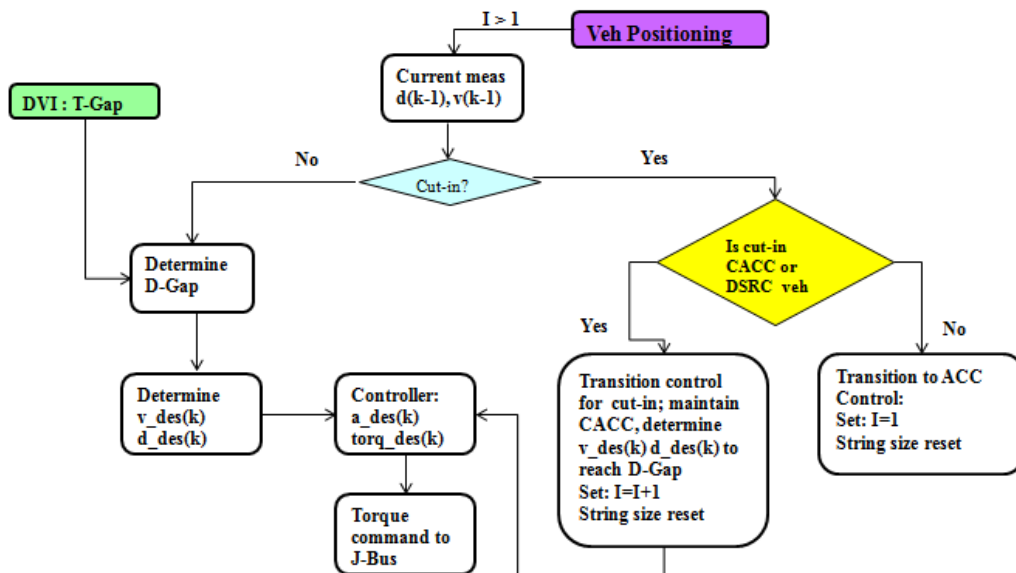

Figure 3-3 Feedforward Control for CACC vehicle $I > 1$

3.3 Logic for Transitions between Scenarios

The transitions among three driving modes are critical for highway driving of CACC vehicles. Basically, there are 3 driving modes when the vehicle is moving, that is:

- Manual driving mode: the driver is taking over the control action, which could happen at anytime for any reason, such as driver's preference, or a situation the CACC cannot handle, or for any safety reasons
- CC: if there is no target close enough detected ahead
- ACC: if there is a target in certain range, say 150 m, which is the effective detection range of the radar and video camera; in this range there is a progressive coupling process involved for the following behavior of the subject vehicle
- CACC: if the front vehicle is in proximity of the desired D-Gap which depends on the T-Gap selected by the driver and vehicle speed

The transitions between those modes are depicted in Figure 3-4. To guarantee smooth transitions between two automatic control modes and from manual mode to an automatic mode, it is necessary to interpolate the reference state trajectory between the two modes within a certain period of time, say, 10 s. This can effectively avoid over-shoot of the control responses.

Transitions between Driving Modes

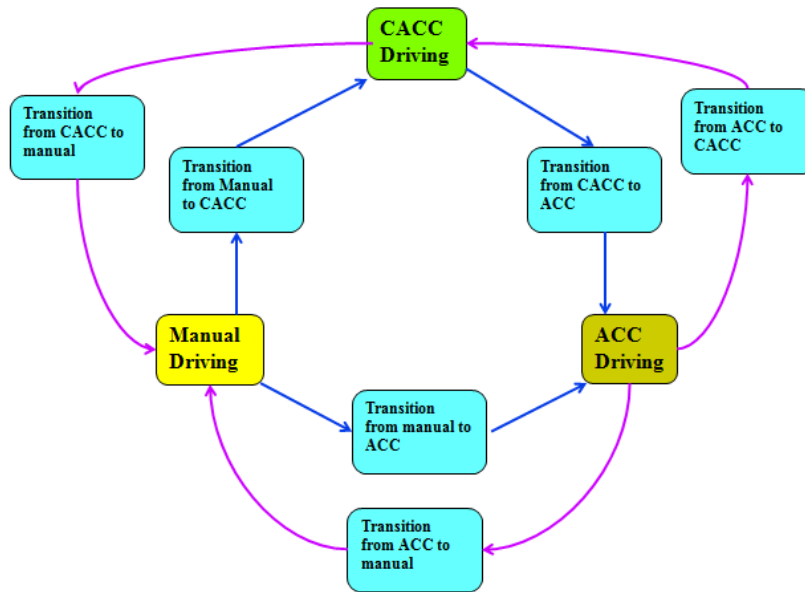

Figure 3-4. Logic for transitions among 3 driving modes: manual, ACC and CACC

In Figure 3-4, the State include: Manual, ACC, and CACC Driving modes.

3.4 Logic for Fault Detection and Handling

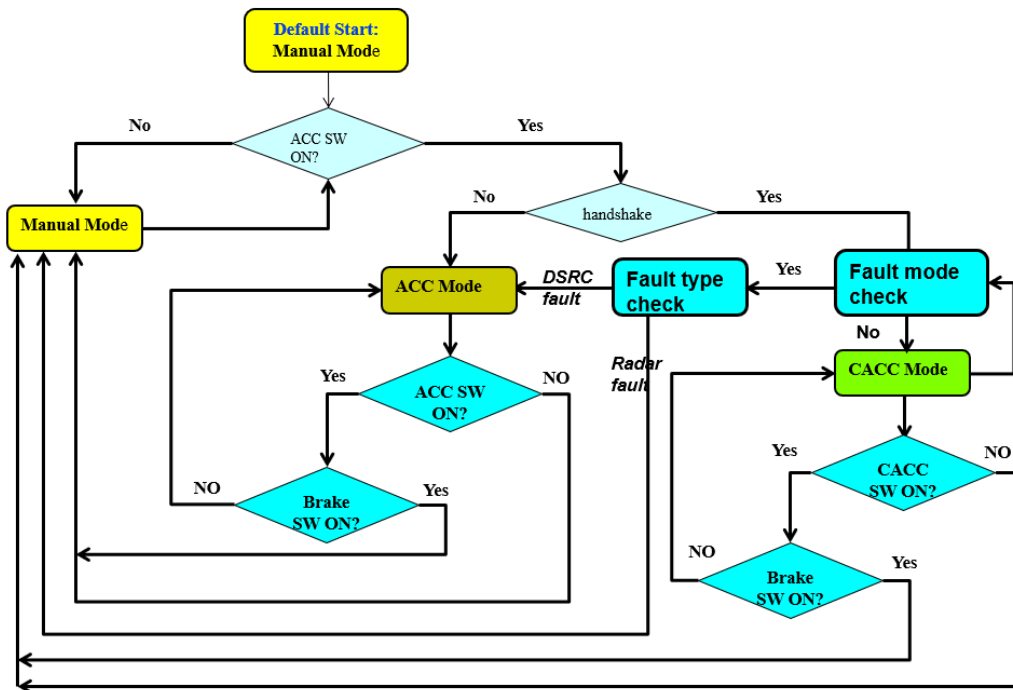

Figure 3-5. Preliminary fault detection and handling for truck CACC system

Fault detection and management is worthy of extensive investigation as an independent project. It would involve the fault detection and management of several parts of the system, to name a few:

- Hardware: central control computer, DSRC, DVI, radar/video camera to front target detection, GPS, other onboard sensors through J-1939 Bus, ...
- Software: all the interface drivers, process scheduling, control command execution, J-1939 Bus interface and data acquisition, ...
- Control: upper/lower level control, any data fault, ...

Figure 3-5 depicts the simple logic as to how the faults are handled if they are detected.

This project only considered some critical and simple faults and developed some preliminary approaches for handling those faults. In particular, the following faults are detected and handled in real-time:

- DSRC fault including packet drop
- Radar/camera for front target detection and tracking fault
- Actuator faults: engine torque control, and braking system fault (engine retarder and or service brake control)
- DVI fault: driver did not input a proper command, or there is a connection fault.

DSRC fault: A DSRC fault is detected by using an integer included in the communication packet, which is increased by one at each interval (100 ms since DSRC is updated at 10 Hz frequency). If there is packet drop for more than 20 time steps, that is 2 s, it is considered as a communication fault. For vehicle 2, it transitions to ACC mode if radar/video camera target detection is still fine; for vehicle 3, there are three cases: (a) fault for communication from vehicle 1; (b) fault for communication from vehicle 2; and (c) fault from both vehicle 1 and 2. Those three faults are handled in different ways. For case (a) vehicle 3 follows vehicle 2 still in CACC mode; for case (b) and (c), vehicle 3 transitions to ACC mode if radar/camera data are fine; otherwise, it transitions to manual mode.

Radar/camera detection fault only: the radar status parameter (target availability) and the target distance usually provide the health condition of the detection and tracking; the response is to directly transition to manual control for the subject vehicle; and vehicle control modes for the other vehicles do not change.

Actuator faults only: the detection can be done using measured acceleration and deceleration compared with the desired values; the response is to directly transition to manual control for the subject vehicle; and vehicle control modes do not change for the other vehicles.

DVI faults: this fault usually comes from the WIFI connection between the DVI unit and the PC-104 computer; if there is a WIFI connection fault, the driving mode will be determined by the health status of the overall system as stated before and the T-Dap (or D-Gap) will be set to level 4

as the default value (for ACC: 1.6 s; for CACC: 1.5 s). Table 3-1 contains the T-Gap implemented for Acc and CACC modes for the trucks. The selection of those numbers was based on driver acceptance and research experience in the past.

Table 3-1 Available Time Gaps Implemented for ACC and CACC Modes

ACC Level	ACC Time Gap [s]		CACC Level	CACC Time Gap [s]
1	1.1		1	0.6
2	1.3		2	0.9
3	1.5		3	1.2
4	1.7		4	1.5
5	1.9		5	1.8

3.5 Lower Level Control

The lower level control maps from the desired acceleration/deceleration to the desired net engine torque or braking torque. From the desired acceleration to desired net engine output torque implicitly requires that the engine torque be initiated through the CAN Bus. This control execution requires a functional relationship which is essentially an inverted vehicle drivetrain dynamics in the following sequence: wheel acceleration → driveshaft torque → final driving gear → propeller shaft → differential → transmission (gear box) → engine output shaft as shown in Figure 3-1. Truck CACC Control System Modeling of [5] (also see the Appendix). The braking torque is shared by the engine brake and foundation (pneumatic or service) brake. The physical principle of the engine retarder is to use the compression stroke without fueling to generate braking torque, which has a much faster response than the service brake. Besides, the braking torque is easier to estimate. However, engine braking tends to have lower braking torque as the engine speed decreases. Therefore, the engine brake is used for vehicle following most of the time. The foundation brake is used instead for emergency situations or complete stopping, which needs larger braking torque. Because of internal logic within the Volvo ACC system, any actuation of the foundation brakes deactivates the ACC, so the foundation brakes could not be used for normal control purposes.

3.6 Stability and String Stability

There are two stability considerations for CACC:

- The feedback control for each vehicle is stable;
- The overall string should be practically string stable.

The robust stability of the closed loop system of the upper level feedback loop is clear based on the choice of coefficients to place the corresponding eigenvalues in the left of the complex plane. The string stability as a whole system involving all the vehicles in the string has been analyzed in [5] (also see the Appendix) in detail, which will not be repeated here.

4 DSRC Communication Messages among Trucks

The DSRC packet is broadcasted by each vehicle every 100 ms (or 10 Hz interval). Each vehicle is expected to receive the data packet from all the other vehicles if the communication is healthy as shown in Figure 2-3. The message sets were published in [7].

4.1 DSRC for CACC/Platooning

Although the BSM (Basic Safety Message) Part I [1, 2] was set as a standard to support cooperative collision warnings, it is not adequate for CACC control. It is therefore necessary to come up with a minimum set of messages which satisfy the needs of CACC as well as active safety (to enhance vehicle and driver safety with automatic control technologies).

PATH has previously developed and field-tested passenger car and heavy-duty-truck CACC on freeways with other traffic, and in support of that work we have defined a set of V2V messages to support CACC functionality. Although more messages passed between vehicles will likely lead to better performance of CACC in general, there should be a minimum set of messages that is adequate for both CACC maneuverability and safety. It makes sense to minimize the size of such messages due to potentially significant overhead of V2V messaging in a practical traffic system since hundreds of vehicles may be within V2V communication range of the subject vehicle. The set of messages suggested here includes messages for maneuvers of individual vehicles within a CACC string, as well as for the coordination of vehicle maneuvers among multiple CACC strings in the same lane and different lanes in real traffic.

The messages include the following data:

- Data for longitudinal control CACC (Cooperative Adaptive Cruise Control) and platooning
- Data for lateral control (this is for future development although not implemented yet)
- Data for maneuvers of individual vehicles within a platoon (or string)
- Data for coordinated maneuvers among multiple platoons (or strings), including exchange of vehicles between two platoons (or strings)
- Data for fault detection and management for safety and maintaining platoon operation under anomalous conditions.

Some of the messages are already included in BSM I (Basic Safety Message I) and BSM II (Basic Safety Message II), but some are newly added for control and coordination purposes. This chapter explains the data sets sorted by their functionalities.

For communication purposes, the data to be transferred are encoded to the needed data types such as integers and then built into communication packets. At the receiving end, the packets are resolved and decoded.

4.2 Data for Control and Active Safety

Society of Automotive Engineers standard SAE J1939 [3] is the standard for heavy vehicle CAN (Control Area Network) bus used for communication and diagnostics among vehicle components. It originated in the diesel-powered bus and heavy-duty truck industry in the United States and is now widely used in other parts of the world. One driving force behind this is the increasing adoption of the engine Electronic Control Unit (ECU), which provides one method of controlling exhaust gas emissions within US and European standards. Control data include those from onboard sensors and J-1939 or other CAN (Control Area Network) Bus and control commands which would directly affect the interactions among the vehicles in the platoon. The minimum set of data used for control usually will depend on the control design method. The set of data listed here are those which PATH has used for platooning of passenger cars, buses and trucks to keep *practical string stability* [4, 5, 6]. This represents 133 bytes plus 3 bits. The following Table 4-1 is a list of messages for both longitudinal and lateral control and active safety.

Table 4-1. DSRC Messages list for control and Active Safety purpose

Data ID	Data name	Units	Range	Data Type	Data Sources	BSM I	BSM II	New Message
1.	Drive mode		1-8	Short int	Individual vehicle operation mode: 0-stop; 1-manual; 2-CC; 3-CACC; 4-const D-Gap Platoon			yes
2.	Vehicle Speed	m/s	0-70	float	Sensor measurement, CAN data	Yes		
3.	Desired t-Gap or D-Gap	s	0-5.0; 0-100.0	float	Driver from DVI on the lead truck			Yes
4.	Set speed	km/hr	5-120	float	Driver selection from DVI			Yes
5.	Distance to preceding vehicle	m	0-150	float	Estimated from sensor data			Yes
6.	UTC Time	s		long int	From GPS	Yes		
7.	GPS Latitude	deg		double	From GPS	Yes		
8.	GPS Longitude	deg		double	From GPS	Yes		
9.	GPS Altitude	m		float	From GPS	Yes		
10.	GPS speed	m/s		float	From GPS	Yes		
11.	GPS Heading			float	From GPS	Yes		
12.	GPS number of satellites			int	From GPS	Yes		
13.	Position Accuracy	m		float	From GPS			Yes

14	Relative Speed to preceding vehicle	m/s	±30	float	Estimated from sensor data			Yes
15	Veh long Acceleration	m/s ²	±10	float	Sensor measurement, CAN data	Yes		
16	Veh lateral Acceleration	m/s ²	±10	float	Sensor measurement CAN data			Yes
17	Road grade	%	±20	float	Sensor measurement CAN data			Yes
18	Brake pedal position	%	0-100%	float	Brake pedal deflection; CAN data			Yes
19	Acceleration pedal position	%	0-100%	float	Acceleration pedal deflection; CAN data		Yes	
20	Fuel rate	g/s	0-100	float	CAN data			Yes
21	ACC Switch	On-off	0-1	bit	CAN data			Yes
22	Resume / Engaged ACC	On-off	0-1	bit	CAN data			Yes
23	Desired speed (control)	m/s	0-70	float	Vehicle speed control command			Yes
24	Desired torque (control)	N-m	0-5000	float	Engine torque control command			Yes
25	Desired deceleration (control)	N-m	0-10	float	Control foundation brake command			Yes
26	Desired transmission retarder torque (control)	N-m	0-5000	float	Control of engine brake command			Yes
27	Desired engine retarder torque (control)	N-m	0-5000	float	Transmission retarder control command			Yes

Data ID	Data name	Units	Range	Data Type	Data Sources	BSM I	BSM II	New Message
28.	Roll rate	Deg/s	-90 ~ +90	float	Sensor measurement CAN data			Yes
29.	Pitch rate	Deg/s	-90 ~ +90	float	Sensor measurement CAN data			Yes
30.	Yaw rate	Deg/s	-90 ~ +90	float	Sensor measurement CAN data			Yes
31.	Roll	deg	-180~ +180	float	Sensor measurement CAN data			Yes
32.	Pitch	deg	-90 ~ +90	float	Sensor measurement CAN data			Yes
33.	Yaw	deg	-180 ~ +180	float	Sensor measurement CAN data			Yes
34.	Steering angle	deg	-720 ~ +720	float	Sensor measurement CAN data			Yes
35.	Lateral position to lane center	m	-10 ~ +10	float	Estimated parameter			Yes
36.	Air Bag Status		0-1	bit	CAN data			Yes

4.3 Data for Coordination of Maneuvers within Platoon

This set of data as listed in *Table 4-2* is used for the coordination of the maneuvers of individual vehicles within a platoon, which is different from the platoon behavior as a collective. The data for coordination are usually defined by the control system designer. The control designer could define a particular meaning of a number which could represent a particular maneuver. To avoid confusion for communication between vehicles of different makes, it is necessary to standardize this set of data. Broadcasting the current maneuver status is very important for control of individual vehicles and safety so that all the vehicles in the same string know what the others are doing right now. Obviously, one of the control strategies for the subject vehicle is to avoid any space-time conflict with other vehicles in the same string for safety, maneuvering efficiency and string stability.

Parameters for maneuver coordination include: the coordination and indication of the maneuver (dynamic interaction) of an individual vehicle in the platoon. This information is also useful from a control viewpoint for the immediately following or preceding platoon to handle the dynamic interaction between platoons. The latter would include, but not be limited to: the time adjustment between platoons, and exchange of vehicles between platoons in the same lane (joining the front platoon from the back) and adjacent lanes (lane change). This represents 16 bytes of data.

Table 4-2. Message list for the coordination of maneuvers with a CACC string/platoon

Data ID	Data name	Units	Range	Data Type	Data Sources	BSM I	BSM II	New Message
1.	Veh unique ID			int	Designated anonymously by platoon leader for control purpose only			Yes
2.	Front cut-in flag		{-1,1}	Short int	Determined from remote sensor and GPS etc.; 1: cut-in; -1: cut-out			Yes
3.	Veh position in group		1 ~ 36	Short int	Determined by DSRC and GPS data			Yes
4.	Vehicle maneuver des		0 ~ 127	Short int	Designated by platoon leader			Yes
5.	Vehicle maneuver ID		0 ~ 127	Short int	Actual maneuver executed, determined by individual vehicle			Yes
6.	Distance to lead vehicle	m	0 ~ 150	float	Estimated from communicated GPS data			Yes
7.	Distance to the preceding vehicle	m	0 ~ 150	float	Estimated from communicated GPS data; the preceding vehicle is the platoon mate; not the cut-in vehicle(s)			Yes

4.4 Data for Fault Detection and Handling

Parameters to represent the current health condition (as listed in Table 4-3 DSRC messages for CACC string/platooning fault detection and management) of the control system are very important information for other vehicles in the same platoon and other platoons nearby (in the same lane or adjacent lane) to make correct decisions for safe maneuvers. This information should include the fault types and the means for handling the fault. Of course, all the other messages are also necessary for this purpose. The outcome of the successful fault handling should be a proper control mode or relevant maneuver to avoid a collision.

It is noted that the vehicle fault mode is represented with a single long integer. The reason is explained as follows: there could be many possible faults/error that could affect automated vehicle control; to name a few: V2V communication drops, lidar/radar detection, other sensors (speed, gyro, road grade, GPS, ...), network switch, CAN and interface, control computer, control software including database, DVI (Driver Vehicle Interface), engine torque control, engine retarder control, torque converter, transmission retarder control, and foundation brake control, etc. Since each component would affect platooning in different aspects and at different levels, all such

information should be built into the Vehicle Fault Mode parameter. To achieve this, one could use a bit-map with each bit (assuming a conventional sequence of order for all possible faults) corresponding to a specific fault. Then this bit map could be converted into a long integer (8 byte) which can represent the fault status of 63 different components. To avoid confusion in the fault mode definition, it is necessary to have a standard which defines the threshold of fault. As examples, if inter-vehicle communication continuously drops for longer than 2 s, it is considered as a communication fault; if the distance estimation discrepancy is over 10% of the actual distance, it is considered as a distance measurement fault; if the relative speed estimation error is over 10% of the actual relative speed, it is considered to have a relative speed measurement error; etc. This quantification should be specified for all parameters that are critical for the control. This represents 12 bytes plus one bit.

Table 4-3 DSRC messages for CACC string/platooning fault detection and management

Data ID	Data name	Units	Range	Data Type	Data Sources	BSM I	BSM II	New Message
1.	Veh fault mode ID			long int	Determined by individual vehicle			Yes
2.	Communication count		0~127	int	For communication fault detection			Yes
3.	Brake Lights or Switch	On-off		bit	Sensor-CAN	Yes		

4.5 Data for coordination between Platoons

This data set (as listed in Table 4-4) is for use in coordinating maneuvers between platoons, including transfers of individual vehicle between platoons, as well as platoon actions as an entity. It could be used for V2V communications between the leaders of two platoons. However, due to power limits and limited range of V2V communication, it may also be passed between the last vehicle in the lead platoon and the leader of the following platoon. Since each vehicle would have a chance to be the leader or the last vehicle in a platoon, for convenience, it would be necessary to include this 21-byte set of data in the V2V communication packet.

Table 4-4 DSRC message list for the coordination between CACC strings/platoons

Data ID	Data name	Units	Range	Data Type	Data Sources	BSM I	BSM II	New Message
1.	Time stamp	hr:min:s: ms	0-23 0-59 0-999	int:int: int:int	Synchronized (or universal) time based on but different form GPS UTC time			Yes
2.	Group ID		0-127	Short int	Designated by roadside coordination manager			Yes
3.	Group size		0-31	Short int	designated by roadside coordination manager			Yes
4.	Group mode		0-31	Short int	Following mode of the platoon; designated by the coordination manger			Yes
5.	Group maneuver des		0-127	Short int	Designated by coordination manager, desired (such as join: acceleration to close the gap to the front platoon)			Yes
6.	Group maneuver ID		0-127	Short int	Representing actual maneuver; designated by platoon leader			Yes

4.6 Concluding Remarks

Communication data is critical for connected automated vehicles. On one hand, it is desirable to pass as much information as possible between vehicles and between the vehicle and the roadside coordination manager. The latter will be necessary if the market penetration of connected automated vehicles is high, but may not be necessary when the market penetration is low. On the other hand, more information passing would mean more communication overhead considering so many vehicles are broadcasting and receiving within the DSRC range. For control performance and safety, it is necessary to have a minimum communication data set. The suggested data sets above are initial suggestions based on the experience in connected automated vehicle control research at California PATH for the past thirty years. Different vehicle types, including both light and heavy-duty vehicles, have been taken into consideration.

If we assume the following data size: short int: 1 bytes; int: 4 bytes; long int: 8 bytes; float: 4 bytes; long float: 8 bytes, the total packet size to contain the suggested data will be 182 bytes plus 4 bits.

5 References

- [1] SAE J2735: Dedicated Short Range Communications (DSRC) Message Set Data Dictionary, SAE International
- [2] SAE J2945/1: On-Board System Requirements for V2V Safety Communications, SAE International
- [3] SAE J1939: https://en.wikipedia.org/wiki/SAE_J1939; accessed on 5/28/2017
- [4] X. Y. Lu and K. Hedrick, 2004, Practical string stability for Longitudinal Control of Automated Vehicles, *Int. J. of Vehicle Systems Dynamics Supplement*, Vol. 41, pp. 577-586
- [5] X. Y. Lu, S.E. Shladover, Integrated ACC and CACC Development for Heavy-Duty Truck Partial Automation, presented at 2017 American Control Conference, (ACC-17), May 24-26, Seattle, WA, USA
- [6] X. Y. Lu and J. K. Hedrick, 2002, A panoramic view of fault management for longitudinal control of automated vehicle platooning, *Proc. of the 2002 ASME Congress*, Nov. 17-22, New Orleans
- [7] X. Y. Lu, Shladover, A. Kailas, and S. Shladover, O. Altan, Messages for Cooperative Adaptive Cruise Control Using V2V Communication in Real Traffic, Fei Wu Eds, to be published by Taylor & Francis Group, CRC Press, 2018
- [8] X. Y. Lu and J. K. Hedrick, 2002, Modeling of heavy-duty vehicles for longitudinal control, *The 6th Int. Symposium on Advanced Vehicle Control*, Hiroshima, Japan, Sept. 9-13, Paper No. 109

6 Appendix: Integrated ACC and CACC Development for Heavy-Duty Truck Partial Automation

This appendix contains the reference paper by Lu and Shladover 2017 presented at the American Control Conference 2017 in Seattle Washington. We have included it here for the convenience of readers of this report.

Integrated ACC and CACC Development for Heavy-Duty Truck Partial Automation

Xiao-Yun Lu* (3942), Steven Shladover (5888), *Member, IEEE*

Abstract— This paper focuses on the design, implementation and field test of integrated Adaptive Cruise Control (ACC) and Cooperative ACC (CACC) with inter-vehicle communication for Heavy-Duty-Truck (HDT). The objective for developing such system is to push automated longitudinal control (partial automation) into market progressively. The control system modeling, integrated ACC and CACC control logics for practical string stability and handling different traffic scenarios such as cut-in and cut-out, and will be considered for CACC strings. Experiments have been successfully conducted with three Volvo trucks on Interstate Highways near Berkeley California with public traffic and professional truck drivers. Results will be briefly presented.

I. INTRODUCTION

This paper focuses on the design, implementation and field test of integrated Adaptive Cruise Control (ACC) and Cooperative ACC (CACC) with inter-vehicle communication. The first vehicle is always in ACC mode for a CACC string to interaction with other vehicles of public drivers. The second vehicle and the vehicle behind will be in CACC mode if wireless communication maintains and if there is no cut-in. The objective for developing such system is to push automated longitudinal control (partial automation) into market progressively. CACC is different from platooning in the following senses: (i) platooning using constant distance gap (D-Gap) while CACC using constant Time Gap (T-Gap) to adapt driver behavior; (ii) platooning is designed for operation in Automated Highway Systems or dedicated lane(s), while CACC is designed for operation in current public traffic. It is well-known from stability analysis and practice that ACC currently in market cannot maintain string stability: if three ACC vehicles running in tandem and if the leader vehicle has large speed fluctuations or has an emergency braking, the third vehicle does not have enough time for response before crashing into the second the vehicle if the following distance is not long enough. This is due to the cumulative total delays (= sensor and processing delays + control actuation delays) from the first vehicle to the following vehicles.

The integration is in the following sense: (a) ACC and CACC have the same control structure; (b) the control design will guarantee fast response and stability of the feedback control of individual vehicles and to maintain *practical string stability* (to be defined later) as a whole system; (c) the control for each vehicle will need to handle interactions with other vehicles such as cut-in and cut-out between the trucks.

Cruise Control (CC), and ACC were extensively studied both in theory and experiment in [1-8], Stop & Go in [9], and automatic lane changing, Collision Warning & Avoidance in

[10-12] (including Emergency Stop and Emergency Lane Change). The CC is simply a speed regulation. By default, ACC involves both inter-vehicle distance and speed control. Results from a 1998 intelligent cruise control field operational test [13] suggested that drivers were attracted to using ACC for two main reasons: the first was the relieved “throttle stress” (the stress of continually activating and deactivating the throttle); and the second was a reduction in “headway stress” which was defined as the ability to perceive range and relative velocity during manual control. While it would be beneficial to have an ACC system that simultaneously considers speed and spacing control, fuel economy, vehicle safety and adaptability to individual driver characteristics, the design of a control system becomes a significant challenge with those multiple objectives taken into account. Interestingly, some research was conducted in this field and meaningful results were obtained [14]. ACC developed by NISSAN Motor Company with algorithm described in [20] and the IDM (Intelligent Driver Model) for ACC presented in [19]; and the CACC controller developed and reported in [17]. Of the three controllers, the IDM controller is the most conservative. Its response is slow and cannot keep the desired constant T-gap – always larger. The ACC controller developed by NISSAN has better response and produce close constant T-Gap and corresponding distance gap. The main problem for ACC is that if three or more ACC vehicles are in tandem, the system is string unstable [15, 16]. In fact, a string unstable coupled group of vehicles on highways is more likely to result in multiple-vehicle crashing, which is believed to be the deadly defects of ACC. To solve this problem, Cooperative Adaptive Cruise Control (CACC) with V2V is necessary.

A combined ACC and CACC design was proposed in [6]. The main advantage of CACC is the fully use of V2V for information passing to reduce time delay and to compensate for remote sensor deficiency in control. The work in [17] presented the first work in the world for CACC control implemented on five passenger cars, and preliminary field tests in public traffic. The CACC control obviously have the fastest response and the minimum speed and distance tracking errors than any ACC controls. Model and simulation in [18] indicate that a simple model representing a first-order lag response can be used to model the previously developed CACC controller.

Most reference on ACC focused on feedback control including to reducing time delay. The ACC design presented in this paper particularly takes into account two extra factors: relationship of the whole string with respect to the front vehicles, even when the distance is outside the desired following distance; considering the ACC to be used in the first vehicle; and string stability of the whole CACC string. Although, remote sensors such as radar most likely can only detect vehicle in the immediate front within certain distance, the range within which the lead vehicle to be taken into account (in coupling) is very important. Besides, the way the

Xiao-Yun Lu, (* corresponding author), Univ. of California at Berkeley, Berkeley Global Campus, 1357 South 46th St., Richmond, CA, 94804-4648 phone: 510-665-3644; e-mail: xiaoyunlu@berkeley.edu;

Steven Shladover, ibid. (e-mail: sess@berkeley.edu).

lead vehicle is coupling with the front vehicle is also important. From the control design viewpoint, this is the feedforward part of the closed-loop control system. Most of the previous study on ACC did not consider those aspects.

The second sense of integration is from the control design: both ACC and CACC feedback control use the same controller in the following senses:

- Upper level control: is based on linear kinematics from desired distance and speed to desired acceleration; Upper level model is independent from vehicle types and sizes, and linear and therefore many legacy or complicated control design method could be used and easily implemented; this approach is particularly favorable for different vehicles types (large or small) from different vehicle makers to be integrated into one string and for large market penetration
- Lower level control: from desired acceleration to desired torque (net engine driving torque or total braking torque); lower level control capture the differences between vehicle longitudinal dynamics, which the manufacturer could produce with their products, again suitable for high level market penetration of different vehicle types and makes

It is obvious that this integrated approach is suitable for massive implementation on different vehicle makes and types.

A. Difference between CACC and Platooning

The main characteristics of ACC/CACC vs. platooning are its Constant time headway which is inherited from common drive behavior. This means that the Distance-Gap (D-Gap) is proportional to the speed. For free-flow traffic, its D-Gap would be Constant. However, for non-homogeneous traffic, the D-Gap is changing, which is a challenge to control.

II. HDT SYSTEM MODELING AND LONGITUDINAL CONTROL

Truck System Modeling and Longitudinal Control: This section will present the modeling approaches used for control design and analysis. To address modeling and controller implementation challenges due to complicated nonlinear vehicle dynamics through driveline, different vehicle types, models and response capabilities. PATH has been adopting model based control design approach since 1990s. This approach can be described as follows: (a) upper level control is based on linear kinematics: from distance and speed tracking error to desired acceleration); and (b) lower level control based on nonlinear vehicle longitudinal dynamics: from desired acceleration to desired engine torque and braking torque. This is essentially a feedback linearization approach. The following Fig. 1 shows the drive line modeling.

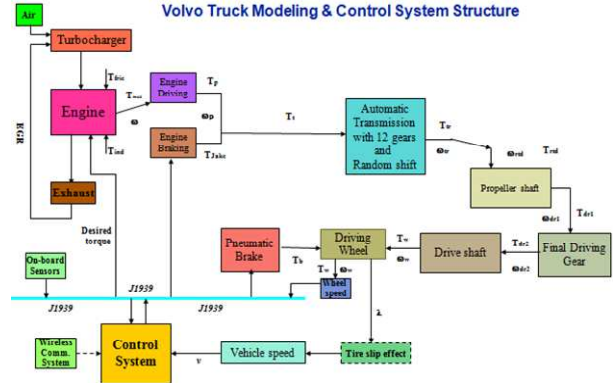

Fig. 1 Driveline modeling and Control system structure

III. UPPER LEVEL CONTROL FOR INTEGRATED ACC & CACC

The main task for upper level control design is to specify the reference trajectory for the subject vehicle.

A. Upper Level Control for ACC

This is divided in two modes: leader vehicle in CC (Cruise Control) and ACC respectively. In CC mode

$$\begin{aligned} \dot{x}_{ref}(t) &= v_{ref}(t) \\ \dot{v}_{ref}(t) &= a_{ref}(t) \end{aligned} \quad (1)$$

In this case, one can generate a continuously differentiable reference speed curve $v_{ref}(t)$ to satisfy those conditions. For CC control, since there is target in the front, such choice of $v_{ref}(t)$ will lead to the following compatibility conditions for speed error and distance error, which means that there is no conflict between the two:

$$\begin{aligned} \dot{x}_e &= v_e \\ \dot{v}_e &= a_e = a - a_{des} \end{aligned} \quad (2)$$

The $v_{ref}(t)$ is designed for ACC of the leader progressively according to the distance to the front target (*progressively coupling*)

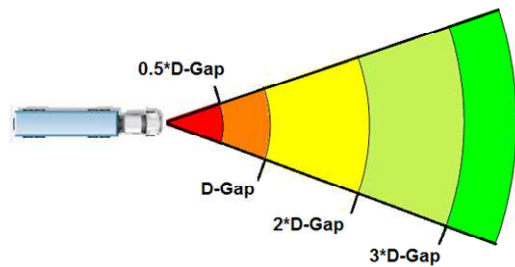

Fig. 2 Progressively coupling with front vehicle based on D-Gap

ACC is used if there is target in the front.

$$\begin{aligned} x_{ref} &= T_{gap} v \\ v_{ref} &= v_{pre} \\ a_{ref} &= a_{pre} \end{aligned} \quad (3)$$

A Progressive Coupling for ACC is proposed to handle the following traffic scenarios:

$$v_{ref}(t) = \begin{cases} V_{max}, & D(t) \geq 3D_{gap} \\ \max\{25, V_{max} - \beta_2(v(t) - v_{pre}(t))\}, & 2D_{gap} \leq D(t) < 3D_{gap} \\ \max\{15, V_{max} - \beta_1(v(t) - v_{pre}(t))\}, & D_{gap} \leq D(t) < 2D_{gap} \end{cases} \quad (4)$$

$$D_{gap} = v(t) \cdot T_{gap}$$

$$\beta_1 > \beta_2 > 0$$

where D_{gap} is the desired distance Gap; T_g is the T-Gap the driver selected. The algorithm can be explained as follows:

- If the target distance is outside $3D_{gap}$, the subject vehicle still use traditional CC
- If the target distance is within the range between $2D_{gap}$ and $3D_{gap}$, the subject vehicle still use CC with reduced speed; the reduction is proportional to the relative speed;
- If the target distance is within the range between D_{gap} and $2D_{gap}$, the situation will be similar but the reduction gain β_1 will be larger (to be more cautiously approaching)

Other vehicle cut-in (from adjacent lane or from onramp) with (a) similar speed; (b) higher speed; or (c) lower speed

- The subject vehicle catch up some slower vehicles in the front
- Other vehicle in the front cut-out: (a) To adjacent lane; and (b) To off-ramp for leaving

The following Fig. 3 depicts the control logics in handling those scenarios for CC and ACC of the lead vehicle.

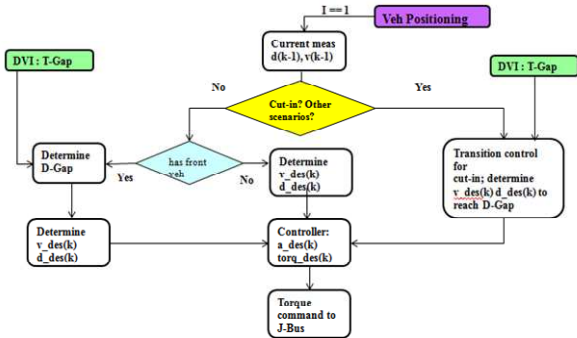

Fig. 3 Control Logics for Veh 1 in CC and ACC mode

A. Upper Level Control for CACC

The referenced state trajectory is chosen for CACC as:

$$\begin{aligned} x_{ref} &= T_{gap} v \\ v_{ref} &= \alpha \cdot v_{pre} + (1 - \alpha) v_{lead} \\ a_{ref} &= \alpha \cdot a_{pre} + (1 - \alpha) a_{lead} \\ 0 &\leq \alpha < 1 \end{aligned} \quad (5)$$

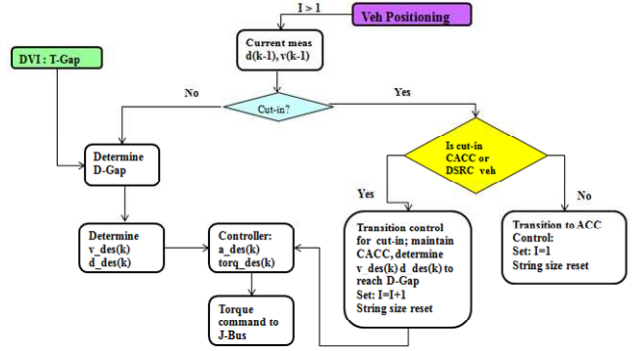

Fig. 4 Control Strategy for CACC vehicle $I > 1$

The following Fig. 4 depicts the control logics in handling the traffic scenarios mentioned before for CACC of the following vehicles.

II. STRING STABILITY CONSIDERATIONS

String stability for CACC needs to consider the following:

- The feedback control for each vehicle is stable;
- The overall string (as a one system) should be string stable in some sense.

The string stability may not be asymptotic due to delay in practice for HDV. It could be bounded stability in some sense to be defined.

A. Stability of Feedback Control for each Vehicle

For $i = 1$: vehicle control is in CC mode, the reference trajectory $(x_{ref}(t), v_{ref}(t), a_{ref}(t))$ can always be chosen as (6) such that

$$\begin{aligned} \ddot{\varepsilon}_i(t) + k_1 \dot{\varepsilon}_i(t) + k_2 \varepsilon_i(t) &= 0 \\ \varepsilon_i(t) &= x_i(t) - x_{ref}(t) \\ \dot{\varepsilon}_i(t) &= v_i(t) - v_{ref}(t) \\ \dot{x}_{ref}(t) &= v_{ref}(t) \\ \dot{v}_{ref}(t) &= a_{ref}(t) \end{aligned} \quad (6)$$

where the coefficients are chosen such that

$$H_0(s) = s^2 + k_1 s + k_2 \quad (7)$$

is Hurwitz polynomial, then the feedback system is asymptotically stable. Besides, the two real roots are chosen as $(-\lambda_1, -\lambda_2)$ such that

$$\lambda_1 > \lambda_2 > 0 \quad (8)$$

with this choice, $k_2 = \lambda_1 \cdot \lambda_2$; $k_1 = -(\lambda_1 + \lambda_2)$

For $i = 1$: vehicle control is in ACC mode,

$$\begin{aligned}\dot{w}_{1,1}(t) &= w_{1,2}(t) \\ \dot{w}_{1,2}(t) &= \dot{w}_{1,1}(t) = -(k_{1,1} - k_{1,2}h)w_{1,2}(t) - k_{1,2}w_{1,1}(t) + \Delta_{1,2}(t) \\ w_{1,1}(t) &= \varepsilon_{1,0}(t) = x_i(t) - x_0(t) \\ w_{1,2}(t) &= \dot{\varepsilon}_{1,0}(t) = v_i(t) - v_0(t) \\ \Delta_{1,2}(t) &= (\dot{a}_0(t) - k_{1,1}a_0(t) - k_{1,2}v_0(t)) + k_{1,2}T_g v_0(t)\end{aligned}$$

where index 0 means the target vehicle in front of the ACC vehicle which is the leader in the CACC string. It is noted that the acceleration, speed and relative distance are all from remote sensor measurement. Therefore, the delay appears in all of them. The coefficients are chosen such that the following polynomial is Hurwitz.

$$H(s) = s^2 + (k_1 - k_2h)s + k_2 \quad (9)$$

Besides, its two roots can be chosen as $(-\lambda_1, -\lambda_2)$ such that they are real as

$$\lambda_1 > \lambda_2 > 0 \quad (10)$$

With this choice, $k_2 = \lambda_1 \cdot \lambda_2$; $(k_1 - k_2h) = -(\lambda_1 + \lambda_2)$

Now, we will show that one ACC vehicle can achieve *bounded stable* following with linear feedback control.

Lemma 1. The ACC feedback of the first vehicle with delays T is bounded stable.

Proof. First, it is clear that the remainder term $\Delta_{1,2}(t)$ is uniformly bounded, i.e. there exists $\delta_1 > 0$ such that

$$|\Delta_{1,2}(t)| < \delta_1, \quad \forall t \geq 0 \quad (11)$$

Now, writing the error dynamics in a matrix form

$$\begin{aligned}\dot{w}_1(t) &= Aw_1(t) + \Delta_1(t) \\ A &= \begin{bmatrix} 0 & 1 \\ -(k_1 - k_2h) & -k_2 \end{bmatrix} \\ w_1(t) &= [w_{1,1}(t), w_{1,2}(t)]^T \\ \Delta_1(t) &= [0, \Delta_{1,2}(t)]^T\end{aligned} \quad (12)$$

Now considering the following Lyapunov function candidate $V(w_1) = w_1^T P w_1$, where P_1 is a 2-dim symmetric positive definite matrix and differentiate $V_1(w_1)$ with respect to the above error dynamics to get

$$\dot{V}_1(w_1) = w_1^T (A^T P + PA) w_1 + 2w_1^T P \Delta_1 \quad (13)$$

Since A is asymptotically stable matrix, i.e. all its eigenvalues are on the left hand side of the complex plain, according system theory [21] it always possible to choose P_1 such that

$$\begin{aligned}A^T P + PA &= -Q \\ A &= \begin{bmatrix} 0 & 1 \\ -(k_1 - k_2h) & -k_2 \end{bmatrix} \\ w_1(t) &= [w_{1,1}(t), w_{1,2}(t)]^T \\ \Delta_1(t) &= [0, \Delta_{1,2}(t)]^T\end{aligned} \quad (14)$$

where Q_1 is positive definite. Since Δ_1 is bounded

$$\dot{V}(w_1) = -w_1^T Q w_1 + 2w_1^T P \Delta_1 \leq -w_1^T Q w_1 + 2\|w_1\|_2 \|P\|_2 \delta_1 \quad (15)$$

Therefore, $\dot{V}(w_1) < 0$ if $\|w_1\|_2$ is large enough. This means that the feedback system is globally uniformly bounded [21].

For $i = 2$

$$\begin{aligned}u_2^d(t) &= a_1(t) - k_1(v_2(t) - v_1(t)) - k_2(x_2(t) - x_1(t+h) - D_{2,1}(t)) \\ &= a_1(t) - k_1(v_2(t) - v_1(t)) - k_2(x_2(t) - x_1(t) - v_1(t)h - T_g v_2(t)) \\ &= a_1(t) - (k_1 - k_2 T_g) \dot{\varepsilon}_{2,1}(t) - k_2 \varepsilon_{2,1}(t) + k_2(T_g - h)v_1(t)\end{aligned}$$

In this case, leader vehicle speed and acceleration are passed through wireless communication directly. Therefore, the delay in the leader vehicle speed and acceleration can be ignored. However, since the distance measure is still based on remote sensor such as radar and lidar. Therefore, the delay h is in the distance error.

$$\begin{aligned}\dot{w}_{2,1}(t) &= w_{2,2}(t) \\ \dot{w}_{2,2}(t) &= -(k_1 - k_2 T_g)w_{2,2}(t) - k_2 w_{2,1}(t) + k_2(T_g - h)v_1(t) \\ w_{2,1}(t) &= \varepsilon_{2,1}(t) \\ w_{2,2}(t) &= \dot{\varepsilon}_{2,1}(t) \\ \Delta_{2,2}(t) &= k_2(T_g - h)v_1(t)\end{aligned} \quad (16)$$

It is noted that the disturbance term $\Delta_{2,2}(t)$ is different from that of the vehicle 1 due to less time delays. With similar arguments as for vehicle 1, and there is a positive definite matrix

For the same positive definite matrix Q , we have

$$\dot{V}_2(w_2) = -w_2^T Q w_2 + 2w_2^T P \Delta_2 \leq -w_2^T Q w_2 + 2\|w_2\|_2 \|P\|_2 \delta_2 \quad (17)$$

For $i > 2$: In this case, the subject vehicle needs to follow both the front vehicle and the leader vehicle. The feedforward signal can be treated as linear interpolation of those from the front and the leader vehicles:

$$\begin{aligned}
u_i^d(t) &= \alpha u_{i-1}(t) + (1-\alpha)u_{i,1}(t) \\
u_{i,i-1}(t) &= a_{i-1}(t-h) - k_1(v_i(t) - v_{i-1}(t)) - k_2(x_i(t) - x_{i-1}(t-h) - D_{i,i-1}(t)) \\
&= a_{i-1}(t) - k_1(v_i(t) - v_{i-1}(t)) - k_2(x_i(t) - x_{i-1}(t) + v_{i-1}(t)h - T_g v_i) \\
&= a_{i-1}(t) - (k_1 - k_2 T_g) \dot{\epsilon}_{i,i-1}(t) - k_2 \epsilon_{i,i-1}(t) + k_2(T_g - h)v_{i-1}(t) \\
u_{i,1}(t) &= a_i(t) - k_1(v_i(t) - v_1(t)) - k_2(x_i(t) - x_1(t-h) - D_{i,1}(t)) \\
&= a_i(t) - (k_1 - k_2 T_g) \dot{\epsilon}_{i,1}(t) - k_2 \epsilon_{i,1}(t) + k_2(T_g - h)v_1(t) \\
0 &\leq \alpha < 1
\end{aligned}$$

$$\begin{aligned}
\dot{w}_{i,1}(t) &= w_{i,2}(t) \\
\dot{w}_{i,2}(t) &= -(k_1 - k_2 T_g)w_{i,2}(t) - k_2 w_{i,1}(t) + \Delta_{i,2}(t) \\
w_{i,1}(t) &= x_i(t) - (\alpha x_{i-1}(t) + (1-\alpha)x_{i-1}(t)) \\
w_{i,2}(t) &= v_i(t) - (\alpha v_{i-1}(t) + (1-\alpha)v_{i-1}(t)) \\
\Delta_{i,2}(t) &= k_2(T_g - h)(\alpha v_i(t) + (1-\alpha)v_1(t))
\end{aligned} \quad (18)$$

It can be observed that:

- The reference trajectory is a linear combination of vehicle ($i-1$) and vehicle 1 (the leader)
- The error dynamics has the same dynamic property as in the case of $i = 1, 2$;
- The $\Delta_{i,2}(t)$ is also a linear combination
- therefore, with the same argument as before, the error dynamics is ultimate bounded and the closed loop system is stable; however, this cannot lead to the conclusion of string stability of the overall system.

A. Theoretical String Stability

Let state tracking error dynamics based the kinematic model be:

$$\begin{aligned}
\epsilon_i(t) &= x_i(t) - x_{i-1}(t) \\
\dot{\epsilon}_i(t) &= v_i(t) - v_{i-1}(t) \\
\ddot{\epsilon}_i(t) &= a_i(t) - a_{i-1}(t)
\end{aligned} \quad (19)$$

Let $E_i(s)$ be the Laplace transformation of $\epsilon_i(t)$ and $G_i(s)$ be the transfer function of the closed loop control system for vehicle i . Then

$$G_i(s) = \frac{E_i}{E_{i-1}} \quad (20)$$

The string stability [22] for automated vehicle platooning of n vehicles requires that

$$\|\epsilon_n\|_\infty \leq \|\epsilon_{n-1}\|_\infty \leq \dots \leq \|\epsilon_1\|_\infty \quad (21)$$

which say that the state trajectory tracking error will not exaggerate from downstream to upstream in the platoon. From linear system theory

$$\begin{aligned}
\|\epsilon_i\|_\infty &\leq \|g_i\|_1 = \int_0^\infty |g(\tau)| d\tau \\
\|g_i \cdot \epsilon_i\|_\infty &\leq \|g_i\|_1 \cdot \|\epsilon_i\|_\infty \\
\|G_i(s)\|_\infty &\leq \|g_i(t)\|_1
\end{aligned} \quad (22)$$

Thus the interconnected system is string stable if $\|g_i(t)\|_1 \leq 1$, and it is string unstable if $\|G_i(s)\|_\infty > 1$.

Due to large time delay in longitudinal dynamics of HDV, it is impossible to use this concept for string stability analysis. We need to extend the practical string stability [16] even further for this purpose, which is discussed next step.

B. Practical String Stability

Assumptions: (1) Information passing through wireless communication can be ignored; this is reasonable since DSRC update rate is $10[Hz]$; (2) delays from internal vehicle sensor reading information through J-1939 Bus is ignored; this is reasonable since speed and acceleration readings are usually every $20[ms]$; (3) All the remote sensor detection and processing delays are lump-summed as h for all vehicles, which only appear in the distance measurement.

Definition 1. In vehicle longitudinal following, two string stability concepts are defined as follows: consider the ratio of the 2-norm of the state trajectory tracing error for any two consecutive vehicle, if for a give constant real number η , there exists a $T_\eta > 0$ such that

$$\begin{aligned}
\frac{\|\epsilon_i(t)\|_1}{\|\epsilon_{i-1}(t)\|_1} &\leq 1 + \eta, \quad t > T_\eta \\
i &= 2, \dots, N
\end{aligned} \quad (23)$$

Hold uniformly for all $t > T_\eta$ and given N .

- if $\eta < 0$, the vehicle following system is said to be *strictly string stable*;
- if $\eta = 0$, the vehicle following system is said to be *marginally string stable*;
- if $\eta > 0$ but η is sufficiently small, the vehicle following system is said to be *string bounded stable*;

Remark 1. Case (i) and (ii) means that the string (or platoon) for vehicle following can be of any length in principle, which is obviously an ideal case and cannot be achieved in practice; in practice, due to delays in control actuators and distance sensors, measurement error, and disturbances of the road geometry, one can never achieve string stability of infinite length. Is it clear that, for case (iii), smaller η will lead to longer string. Based on the past experiences at California PATH, for passenger cars, this number is about 10~15; and for heavy-duty trucks, this number is about 4~5 approximately.

Theorem 1. Practical string stability for longitudinal vehicle following: with the following strategy stated above, for a

given $\eta > 0$, there exists T_η and N such that the overall system (with N vehicles) is string bounded stable.

Proof. The homogeneous part of error dynamics has the following general solution:

$$y = c_1 y_1 + c_2 y_2, \quad y_1 = e^{-\lambda_1 t}, \quad y_2 = e^{-\lambda_2 t}$$

For chosen (λ_1, λ_2) as in (10), find the Wronskian of (y_1, y_2) as follows:

$$W = \begin{vmatrix} y_1 & y_2 \\ \dot{y}_1 & \dot{y}_2 \end{vmatrix} = \begin{vmatrix} e^{-\lambda_1 t} & e^{-\lambda_2 t} \\ -\lambda_1 e^{-\lambda_1 t} & -\lambda_2 e^{-\lambda_2 t} \end{vmatrix} = (\lambda_1 - \lambda_2) e^{-\lambda_1 t - \lambda_2 t} \neq 0, \quad \forall t$$

Therefore (y_1, y_2) are fundamental solutions. The general solution of the non-homogeneous error dynamics is:

$$\begin{aligned} \varepsilon_i &= c_1 e^{-\lambda_1 t} + c_2 e^{-\lambda_2 t} + \left[-e^{-\lambda_1 t} \int_0^t \frac{e^{-\lambda_2 \tau} \Delta_{i,2}(\tau)}{W(\tau)} d\tau + e^{-\lambda_2 t} \int_0^t \frac{e^{-\lambda_1 \tau} \Delta_{i,2}(\tau)}{W(\tau)} d\tau \right] \\ &= c_1 e^{-\lambda_1 t} + c_2 e^{-\lambda_2 t} + \left[-e^{-\lambda_1 t} \int_0^t \frac{e^{-\lambda_2 \tau} \Delta_{i,2}(\tau)}{(\lambda_1 - \lambda_2) e^{-\lambda_1 \tau - \lambda_2 \tau}} d\tau + e^{-\lambda_2 t} \int_0^t \frac{e^{-\lambda_1 \tau} \Delta_{i,2}(\tau)}{(\lambda_1 - \lambda_2) e^{-\lambda_1 \tau - \lambda_2 \tau}} d\tau \right] \\ &= c_1 e^{-\lambda_1 t} + c_2 e^{-\lambda_2 t} + \frac{1}{(\lambda_1 - \lambda_2)} \left[-e^{-\lambda_1 t} \int_0^t e^{\lambda_2 \tau} \Delta_{i,2}(\tau) d\tau + e^{-\lambda_2 t} \int_0^t e^{\lambda_1 \tau} \Delta_{i,2}(\tau) d\tau \right] \\ i &= 2, \dots, N \end{aligned}$$

$$\Delta_{2,2}(t) = \lambda_1 \lambda_2 (T_g - h) v_1(t)$$

$$\Delta_{i,2}(t) = \lambda_1 \lambda_2 (T_g - h) (\alpha v_{i-1}(t) + (1-\alpha) v_1(t)), \quad i > 2$$

Since the first part, i.e. the general solution of the homogeneous part of the error dynamics approaches 0 exponentially, it is only necessary to consider the second part, i.e. the special solution of the non-homogeneous error dynamics:

$$\begin{aligned} \frac{|\varepsilon_{i+1}|}{|\varepsilon_i|} &\approx \frac{-e^{-\lambda_1 t} \int_0^t e^{\lambda_2 \tau} \Delta_{i+1,2}(\tau) d\tau + e^{-\lambda_2 t} \int_0^t e^{\lambda_1 \tau} \Delta_{i+1,2}(\tau) d\tau}{-e^{-\lambda_1 t} \int_0^t e^{\lambda_2 \tau} \Delta_{i,2}(\tau) d\tau + e^{-\lambda_2 t} \int_0^t e^{\lambda_1 \tau} \Delta_{i,2}(\tau) d\tau} \\ &= \frac{-e^{-\lambda_1 t} \int_0^t e^{\lambda_2 \tau} (\alpha v_i(\tau) + (1-\alpha) v_1(\tau)) d\tau + e^{-\lambda_2 t} \int_0^t e^{\lambda_1 \tau} (\alpha v_i(\tau) + (1-\alpha) v_1(\tau)) d\tau}{-e^{-\lambda_1 t} \int_0^t e^{\lambda_2 \tau} (\alpha v_{i-1}(t) + (1-\alpha) v_1(t)) d\tau + e^{-\lambda_2 t} \int_0^t e^{\lambda_1 \tau} (\alpha v_{i-1}(t) + (1-\alpha) v_1(t)) d\tau} \\ &\Rightarrow \frac{|\varepsilon_{i+1}|}{|\varepsilon_i|} - 1 = \frac{-\alpha e^{-\lambda_1 t} \int_0^t e^{\lambda_2 \tau} (v_i(\tau) - v_{i-1}(\tau)) d\tau + \alpha e^{-\lambda_2 t} \int_0^t e^{\lambda_1 \tau} (v_i(\tau) - v_{i-1}(\tau)) d\tau}{-e^{-\lambda_1 t} \int_0^t e^{\lambda_2 \tau} (\alpha v_{i-1}(t) + (1-\alpha) v_1(t)) d\tau + e^{-\lambda_2 t} \int_0^t e^{\lambda_1 \tau} (\alpha v_{i-1}(t) + (1-\alpha) v_1(t)) d\tau} \end{aligned}$$

Since $\lambda_1 > \lambda_2$ as in (10)

$$\int_0^t e^{\lambda_1 \tau} (\alpha v_{i-1}(t) + (1-\alpha) v_1(t)) d\tau > 0$$

$$\int_0^t e^{\lambda_2 \tau} (\alpha v_{i-1}(t) + (1-\alpha) v_1(t)) d\tau > 0$$

$$\begin{aligned} \frac{|\varepsilon_{i+1}|}{|\varepsilon_i|} - 1 &= \frac{-\alpha e^{-\lambda_1 t} \int_0^t e^{\lambda_2 \tau} (v_i(\tau) - v_{i-1}(\tau)) d\tau + \alpha e^{-\lambda_2 t} \int_0^t e^{\lambda_1 \tau} (v_i(\tau) - v_{i-1}(\tau)) d\tau}{-e^{-\lambda_1 t} \int_0^t e^{\lambda_2 \tau} (\alpha v_{i-1}(t) + (1-\alpha) v_1(t)) d\tau + e^{-\lambda_2 t} \int_0^t e^{\lambda_1 \tau} (\alpha v_{i-1}(t) + (1-\alpha) v_1(t)) d\tau} \\ &= \frac{\alpha e^{-\lambda_1 t} \int_0^t e^{\lambda_2 \tau} (v_i(\tau) - v_{i-1}(\tau)) d\tau + \alpha e^{-\lambda_2 t} \int_0^t e^{\lambda_1 \tau} (v_i(\tau) - v_{i-1}(\tau)) d\tau}{-e^{-\lambda_1 t} \int_0^t e^{\lambda_2 \tau} (\alpha v_{i-1}(t) + (1-\alpha) v_1(t)) d\tau + e^{-\lambda_2 t} \int_0^t e^{\lambda_1 \tau} (\alpha v_{i-1}(t) + (1-\alpha) v_1(t)) d\tau} \\ &= \frac{\alpha e^{-\lambda_1 t} \int_0^t e^{\lambda_2 \tau} (v_i(\tau) - v_{i-1}(\tau)) d\tau + \alpha e^{-\lambda_2 t} \int_0^t e^{\lambda_1 \tau} (v_i(\tau) - v_{i-1}(\tau)) d\tau}{e^{-\lambda_2 t} \left[\int_0^t (e^{\lambda_2 \tau} - e^{\lambda_1 \tau}) (\alpha v_{i-1}(t) + (1-\alpha) v_1(t)) d\tau \right]} \\ &= \frac{\alpha e^{-\lambda_1 t} \int_0^t (e^{\lambda_2 \tau} + e^{\lambda_1 \tau}) (v_i(\tau) - v_{i-1}(\tau)) d\tau}{e^{-\lambda_2 t} \left[\int_0^t (e^{\lambda_2 \tau} - e^{\lambda_1 \tau}) (\alpha v_{i-1}(t) + (1-\alpha) v_1(t)) d\tau \right]} \end{aligned}$$

For vehicle speeds $v_{i-1}(t) > 1, v_1(t) > 1$,

$\alpha v_{i-1}(t) + (1-\alpha) v_1(t) > 1$. Therefore, it holds that

$$\begin{aligned} \left| \frac{\varepsilon_{i+1}}{\varepsilon_i} - 1 \right| &\leq \frac{\alpha e^{-\lambda_2 t} \int_0^t (e^{\lambda_1 \tau} + e^{\lambda_2 \tau}) (v_i(\tau) - v_{i-1}(\tau)) d\tau}{e^{-\lambda_2 t} \left[\int_0^t (e^{\lambda_2 \tau} - e^{\lambda_1 \tau}) d\tau \right]} \\ &= \frac{\alpha \delta_{i,i-1} e^{-\lambda_2 t} \int_0^t (e^{\lambda_1 \tau} + e^{\lambda_2 \tau}) d\tau}{\frac{1}{\lambda_1} (e^{(\lambda_1 - \lambda_2)t} - e^{-\lambda_2 t}) - \frac{1}{\lambda_2} (1 - e^{-\lambda_2 t})} \\ &\leq \frac{\alpha \delta_{i,i-1} \left[\frac{1}{\lambda_1} (e^{(\lambda_1 - \lambda_2)t} - e^{-\lambda_2 t}) + \frac{1}{\lambda_2} (1 - e^{-\lambda_2 t}) \right]}{\frac{1}{\lambda_1} (e^{(\lambda_1 - \lambda_2)t} - e^{-\lambda_2 t}) - \frac{1}{\lambda_2} (1 - e^{-\lambda_2 t})} \\ &\rightarrow \alpha \delta_{i,i-1} \quad \text{if } t \rightarrow \infty \end{aligned}$$

Where it is true from previous analysis that there exists constants $\delta_{i,i-1}$ such that

$$(v_i(\tau) - v_{i-1}(\tau)) \leq \delta_{i,i-1}$$

Now, for given $\eta > 0$, there exists $t > T_\eta$ and small enough α such that, for all $t > T_\eta$

$$\alpha \delta_{i,i-1} < \eta$$

$$\frac{|\varepsilon_{i+1}|}{|\varepsilon_i|} \leq 1 + \eta$$

This completes the proof.

I. LOWER LEVEL CONTROL

The model represents the relationship between desired acceleration/deceleration from the upper level control to desired engine torque, or desired braking torque which is disseminated to engine brake control and pneumatic (service) brake control.

A. Engine Torque Control

Due to the built-in engine controller, it is impossible to directly access the fuel rate command. Instead, desired is used as input. This section emphasizes on brake control. There are two fundamentally different pure time delays.

Case 1: with inter-vehicle communication

Relative distance of the subject vehicle is estimated from distance sensor(s) (such as radar and/or lidar)

Case 2: Without inter-vehicle communication

$$a_{des} = \frac{r_d r_g T_{des} - (r_d T_{rid} + T_b + F_d h_r + F_r h_r + Mgh_r \sin \theta)}{\bar{I}} \quad (24)$$

$$\bar{I} = r_d^2 r_g^2 \frac{I_e}{h_r} + r_d^2 \frac{I_{tr}}{h_r} + r_d^2 \frac{I_{dr1}}{h_r} + \frac{I_{dr2}}{h_r} + \frac{I_w}{h_r} + Mh$$

$$T_{des} = \frac{\bar{I} a_{des} + (r_d T_{rid} + T_b + F_d h_r + F_r h_r + Mgh_r \sin \theta)}{r_d r_g}$$

The last is the mapping from desired acceleration to desired torque. This is the torque command to be sent to the vehicle through J-1939 Bus for control.

A. Braking System Control

Braking system for automatic control is composed of two parts: Jake brake, and pneumatic brake. Each part has its own characteristics. To understand these characteristics for braking system control strategy is the key factor for good performance of the control system and safety. Engine has limited braking torque with faster response and delay less than $200[ms]$. The service brake has larger braking capability with much larger delay, say $500[ms] \sim 1.5[s]$ depending on make and air pressure on reservoir. Due to those characteristics, the following strategy is used maximum use of engine brake

The total feasible braking torque on all wheels is

$$\begin{cases} T_{jk} = 0, T_p = 0 & T_b \leq T_f \\ T_{jk} = T_b & T_f \leq T_b \leq T_{jk}^{(max)} \\ T_p = T_b & T_{jk}^{(max)} \leq T_b \leq T_p^{(max)} \\ T_{jk} + T_p = T_b & T_b > T_p^{(max)} \end{cases} \quad (25)$$

II. TEST RESULTS

Test Results: this section will present field test results of three Volvo trucks in public traffic on Interstate Highway I-80 and I-580, and Highway 4 near Berkeley California, and with professional truck drivers. The maximum speed is $55[mp]$. Figure 5 shows how the three vehicles behave in steady-state following to maintain string stability and in cut-in and cut-out maneuvers by other vehicles.

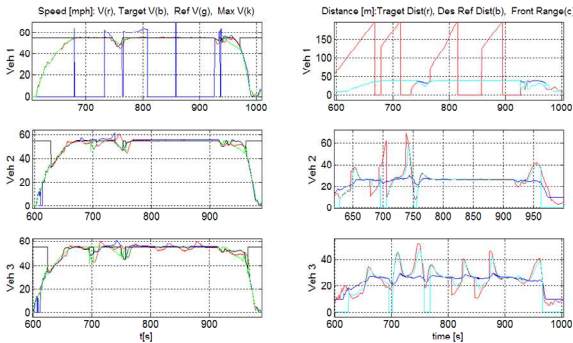

Fig. 5. Three truck CACC with other vehicles cut-in and cut-out: speed and distance trajectories

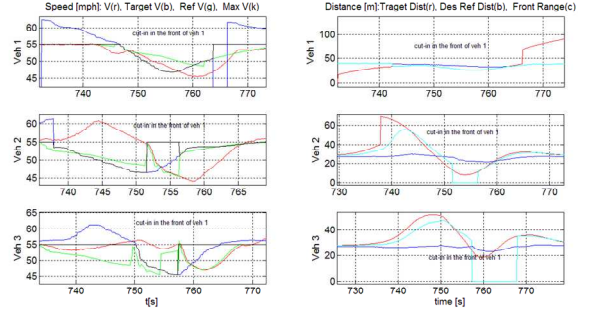

Fig. 6. Three-truck CACC with other vehicles cut-in and cut-out: speed and distance trajectories (zoomed)

Figure 6 is zoomed from Fig. 5, which shows in more details for the vehicle in the string to handling other vehicle cut-in and cut-out scenarios.

III. CONCLUSION

An integrated ACC and CACC control systems have been developed for HDT to be driven in the public traffic with other vehicles. This is believed to be a milestone to push the automated and connected vehicle technologies progressively into market. The leader vehicle has to dynamically handle vehicles of its front. A progressive coupling approach is proposed which has been tested as successful. Each vehicle has to handle maneuvers of other vehicles including cut-in and cut-out. A generalized concept of *practical string stability* has been extended from previous work and used to analyze the dynamic behavior of the CACC string to HDT. This concept can also be used for other vehicles in CACC mode which is different from automated vehicle platooning in both riving environment and feedforward part in control.

APPENDIX: NOTATION LIST

The following notations are used throughout the paper:

- $x(t)$ – distance w. r. t. an inertia coordinate system
- $v(t)$ – speed w. r. t. the inertia coordinate system
- $a(t)$ – acceleration w. r. t. the inertia coordinate system
- $x_{pre}(t)$ – relative distance to the preceding vehicle
- $v_{pre}(t)$ – preceding vehicle speed measure
- $a_{pre}(t)$ – p receding vehicle acceleration measured
- $x_{ref}(t)$ – reference distance for control w. r. t. an inertia coordinate system
- $v_{ref}(t)$ – reference speed for control w. r. t. the inertia coordinate system
- $a_{des}(t)$ – desired acceleration for control
- T_g – Time Gap (T-Gap) the driver selected
- $D_{gap}(t) = T_g \cdot v(t)$ – distance gap (D-Gap) for control
- T_b – desired braking torque
- T_{jk} – engine brake to be applied

$T_{jk}^{(\max)}(\omega)$ – maximum engine braking torque
 T_p – desired service braking torque
 $T_p^{(\max)}$ – maximum air braking torque can be obtained

ACKNOWLEDGMENT

This research was supported by the Federal Highway Administration’s Exploratory Advanced Research Program under Cooperative Agreement No. DTFH61-13-R-00011, with cost sharing by the State of California Transportation Agency, Department of Transportation (Caltrans). The contents of this paper reflect the views of the authors, who are responsible for the facts and accuracy of the data presented herein. The contents do not necessarily reflect the official views or policies of the Federal Highway Administration or the State of California. Strong technical support for implementation and tests from Stefan Bergquist and Aravind Kailas of Volvo Truck Inc. and PATH staff John Spring and David Nelson is gratefully acknowledged.

REFERENCES

- [1] D. Baum, C. D. Hamann and E. Schubert, High performance ACC system based on sensor fusion with distance sensor, image processing unit, and navigation system, *Vehicle Systems Dynamics*, vol.28, no.6 pp. 327-338, 1997.
- [2] C.Y. Liang and H. Peng, Optimal adaptive cruise control with guaranteed string stability, *Vehicle Systems Dynamics*,” vol. 31, pp. 313-330, 1999.
- [3] A. Fritz, W. Schiehlen Nonlinear ACC in simulation and measurement, *Vehicle System Dynamics*, vol. 36, September 2001, pp. 159-177(19)
- [4] J. Bengtsson, Adaptive Cruise Control and driver modeling, *Report of Dept. of Automatic Control*, Lund Inst. of Technology, TNO report, no. 03.OILAC.028.1/RHA, Nov. 2001.
- [5] G. Marsden, M. McDonald and M. Brackstone, Towards an understanding of adaptive cruise control, *Transportation Research, Part C*, vol. 9, pp.33-51, 2001.
- [6] X. Y. Lu, J. K. Hedrick and M. Drew, ACC/CACC - Control design, stability and robust performance, *Proc. of American Control Conference - 2002*, pp. 4327-4332, May 8-10, 2002a, Anchorage, Alaska.
- [7] Y. Yamamura, Y. Seto, H. Nishira and T. Kawabe, An ACC design method for achieving both string stability and ride comfort,” *Journal of System Design and Dynamics*, vol. 2, Issue 4, 2008, pp. 979-990.
- [8] K. Yi, N. Ryu, H. J. Yoon, K. Huh, D. Cho, I. Moon, Implementation and vehicle tests of a vehicle stop-and-go cruise control system, *Journal of Automobile Engineering*, vol. 216, no.7, pp.537-544, 2002.
- [9] K. Yi, J. Hong and Y. D. Kwon, A vehicle control algorithm for stop-and-go cruise control, *Journal of Automobile Engineering*, vol. 215, no.10, pp.1099-1115, 2001
- [10] T. Acarman, Y. Pan and U. Ozguner, A control authority transition system for collision avoidance, *Vehicle System Dynamics: International Journal of Vehicle Mechanics and Mobility*, vol.39, Issue 2, pp.149-187, 2003.
- [11] Delphi, Collision Warning Systems, Forewarn Adaptive Cruise Control with Driver Alert, <http://www.delphi.com>
- [12] X. Y. Lu, S. Shladover, and W. B. Zhang, Quantitative testing of a frontal collision warning system for transit buses, *IET ITS*, vol. 1, pp. 215-223, 2007.
- [13] P. Fancher, R. Ervin, J. Sayer, M. Hagan, S. Bogard, Z. Bareket, M. Mefford, J. Haugen., Intelligent Cruise Control Field Operational Test. *Final Report*, DOT HS 808 849. May, 1998.
- [14] S. Li, K. Li, R. Rajamani, J. Wang, Model Predictive Multiple-Objective Vehicular Adaptive Cruise Control, *IEEE Trans. Contr. Syst. Tech.*, pp.556-566, May, 2010.
- [15] X. Y. Lu and J. K. Hedrick, “Practical string stability, *18th IAVSD Symposium on Dynamics of Vehicles on roads and Tracks (Int. Association of Vehicle System Dynamics)*, August 25-29, 2003, Atsugi, Kanagawa, Japan.
- [16] X. Y. Lu and K. Hedrick, Practical string stability for Longitudinal Control of Automated Vehicles, *Int. J. of Vehicle Systems Dynamics Supplement*, vol.41, pp. 577-586, 2004.
- [17] Milanés, V. and S. E. Shladover, Modeling cooperative and autonomous adaptive cruise control dynamic responses using experimental data, *Transportation Research Part C: Emerging Technologies* 48: 285-300, 2014
- [18] V. Milanés, S. Shladover, J. Spring, C. Nowakowski, H. Kawazoe, and M. Nakamura, Cooperative Adaptive Cruise Control in Real Traffic Situations’. *IEEE Transactions on Intelligent Transportation Systems* 15(1):296–305, 2014
- [19] M. Treiber, et al. (2000). Congested Traffic States in Empirical Observations and Microscopic Simulations. *Physical Review E* 62:1805–1824.
- [20] Y. Yamamura, Y. Seto, H. Nishira and T. Kawabe, A design method for string stable ACC,
- [21] H. K. Khalil, *Nonlinear Systems*, Second Ed., Prentice Hall, New Jersey, 1996
- [22] Swaroop, D. and Hedrick, J. K., String stability of interconnected systems, *IEEE Trans. Auto. Contr.*, **40**, no.3, p349-357, 1996